



Elnet GR\PQ

Electrical Measurements & Power Quality

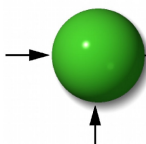

Table of Contents

CHAPTER 1	INTRODUCTION.....	5
1.1	About the <i>ELNet</i> Meter.....	5
1.2	How to use this manual	6
1.3	Safety Information.....	8
1.4	Warranty	9
1.5	Your comments are welcome.....	11
1.6	Disclaimer.....	12
CHAPTER 2	— INSTALLATION.....	13
2.1	Contents of packaging	14
2.2	Mechanical mounting	15
2.3	Wiring Schematics	17
2.4	Rear Panel Connections	21
2.5	Digital Outputs and Inputs.	26
2.6	Manufacturing Data.	27
CHAPTER 3	— USING THE <i>ELNet</i> Meter.....	28
3.1	Front Panel.....	28
3.2	Control Buttons.....	29
3.3	Lock Utility	30
CHAPTER 4	— NECESSARY <i>ELNet</i> SETTINGS.....	32
4.1	Settings for Current Transformer	33
4.2	Electrical Connection Check.....	36

4.3	TOU Setting.....	39
4.4	Change language.....	40
4.5	Time Settings.....	41
4.6	Date Settings.....	42
4.7	Setting digital out.....	43
4.8	Delta/Star Electrical network definition	44
4.9	Demand Setting.....	45
CHAPTER 5 — FRONT PANEL DISPLAYS.....		46
5.1	Current for 3 Phases.....	46
5.2	Frequency for 3 Phases.....	47
5.3	Current in Neutral Line	48
5.4	Voltage for 3 Phases.....	49
5.5	Active Power for all 3 Phases (P).....	50
5.6	Reactive Power for all 3 Phases (Q)	52
5.7	Apparent Power for all 3 Phases (S).....	53
5.8	Power Factor for each Phase.....	54
5.9	Overall Power Factor	55
5.10	Active/ Reactive/ Apparent Energy	56
5.11	Power Quality	57
5.11.1	Wave Form Graphs	57
5.11.2	Harmonics Bar Graphs	59
5.11.3	Voltage Total Harmonic Distortion (THD). 61	
5.11.4	Current Total Harmonic Distortion (THD) 62	

5.11.5 Current THD,TDD,KF63

5.11.6 EN50160 event monitoring and Wave records64

5.11.7 Long PQ event special record66

CHAPTER 6 — ALARM REPORT..... 70

6.1. Alarm setting.....71

6.2. Display Alarms Report73

6.3. Display EN50160 Event Report74

CHAPTER 7 — DEMAND REPORTS 75

CHAPTER 8 — DATA LOGGING76

CHAPTER 9 — COMMUNICATION.....79

9.1 Communication Connections.....79

9.2 Communication Settings79

9.3 Address79

9.4 Baud Rate80

9.5 Parity80

9.6 Communication Set Up81

9.7 Communication with UniArt Software84

CHAPTER 10 — Specifications86

10.1 Measurement & Display.....87

Appendix A — Installation & Configuration Check List...89

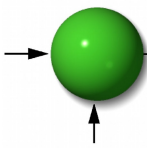

CHAPTER 1 INTRODUCTION

1.1 About the *ELNet* Meter

Large consumers of electricity e.g. factories, hotels, hospitals, municipalities, need to know the history of their consumption and the quality of the power supply. Details such as Voltage, Current, Power Factor, Hertz, Neutral Current, Energy Demands and all electricity related events are recorded in the ***ELNet*** Energy & Powermeter.

An additional feature of the Meter is the ability to measure Harmonics. Part of the Electricity Supply Authority's bill reflects poor or good Harmonics in the consumer's system, therefore it is in his interest to monitor Harmonics and try to improve it.

These are all recorded on a continual basis and can be recalled and shown on the front panel display of the instrument with a few simple key-strokes any time the user wishes.

The ***ELNet*** Energy & Powermeter is a compact, multi functional, three-phase Meter simple to install and is especially designed to integrate into Building Management Systems. It requires no special mounting and is ideally suited for mounting on the front face of any standard electrical panel.

The Configuration and Setup is menu driven, with password protection.

Communication with external devices is simple and is based on standard known technology.

The ***ELNet*** Energy & Powermeter boasts a new innovative built in "Flash Memory", which pioneers a new frontier into electrical measurement. It has a 1 MB of FLASH MEMORY with a capacity of recording up to 2 years of power malfunctions and interruptions.

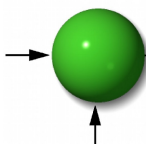

Readings, graphs, tables & history are shown on the graphic display of the **ELNet** Energy & Powermeter. This display is a state of the art screen with a resolution of 160X128.

Each **ELNet** Energy & Powermeter is carefully and meticulously manufactured using quality components and the latest production methods. Before leaving the factory each **ELNet** Energy & Powermeter is calibrated and sent to the customer accompanied by the test certificate and Certificate of Compliance (C.O.C).

1.2 How to use this manual

We at CONTROL APPLICATIONS Ltd, envisage this manual to be used by three types of people, i.e. the **Installation Technician**, the **Senior Electrical Engineer** and the end **User**. For this reason this manual is divided into chapters for ease of reference by each of these different people. There could be a situation where two of the abovementioned tasks can be combined, or in a rare instance one person could handle all three tasks.

CHAPTER 1, *Introduction*, describes the **ELNet** Energy & Powermeter, its potential users, the readings it can provide and some of its features in brief.

CHAPTER 2, *Installation*, provides detailed instructions for unpacking, mechanical mounting, and electrical wiring up instructions for the **Installation Technician**.

CHAPTER 3, *Using the ELNet* Energy & Powermeter, describes in detail front Panel, the functions of the control buttons, and the Lock Utility.

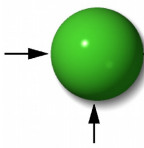

CHAPTER 4, *Parameter Configuration & Settings* explains in detail the minimum parameters settings needed by the **Senior Electrical Engineer** to set up and configure the **ELNet** Energy & Powermeter.

CHAPTER 5, *Front Panel Displays*, is an easy to follow step-by-step guide to obtain readings, graphs, tables and histories for the **User**.

CHAPTER 6, *Alarm reports* gives details about how to program the Alarms in the **ELNet** Energy & Powermeter.

CHAPTER 7, *Demand reports* is an easy to follow step-by-step guide to obtain the Demand reports up to 2 years.

CHAPTER 8, *Data Logging* is an easy to follow step-by-step guide to obtain all the stored peaks of current, voltage, energy, power factor etc. up to 2 years of data logging.

CHAPTER 9, *Communications* gives details about the Communication capabilities of the **ELNet** Energy & Powermeter, and how to Set Up.

CHAPTER 10, *Specifications*, is a detailed list of specifications of the **ELNet** Energy & Powermeter.

APPENDIX A, *Installation & Configuration Check List*, provides a Check List to insure no important steps will be missed during the initial set up.

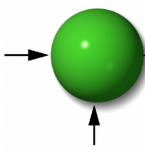

1.3 Safety Information

The purpose of this manual is to help you. Please read the instructions carefully before performing any installation and note any precautions.

WARNING

- Ensure that all incoming AC power and other power sources are turned off before performing any work on the **ELNet** Energy & Powermeter. Failure to do so may result in serious or even fatal injury and/or equipment damage.
- If the **ELNet** Energy & Powermeter is damaged in any way do NOT connect it to any power source.
- To prevent a potential fire or shock hazard, never expose the **ELNet** Energy & Powermeter to rain or moisture.
- Keep the surrounding area free of dirt and clutter especially metal objects. Good housekeeping pays.
- Inspect the cables periodically for cracks, kinks or any other signs of wear
- Keep children away.
- Do not pull the cords.
- Users should stay alert and not approach the rear of the **ELNet** Energy & Powermeter while tired or under the influence of alcohol, medicines or any other chemical substance that would tend to make a person drowsy.
- Do not wear loose clothing or dangling jewelry.
- Above all use common sense at all times.

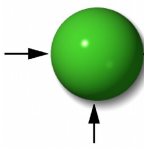

1.4 Warranty

CONTROL APPLICATIONS Ltd provides a 12- Month warranty against faulty workmanship or components from date of dispatch provided that the product was properly installed and used.

CONTROL APPLICATIONS Ltd does not accept liability for any damage that may be caused by natural disasters (such as floods, fire, earthquake, lightening etc.).

CONTROL APPLICATIONS Ltd does not accept liability for any damage that may be caused by malfunction of the ***ELNet*** Energy & Powermeter.

CONTROL APPLICATIONS Ltd will advise the customer on the proper installation and use of the ***ELNet*** Energy & Powermeter, but will not accept any responsibility that the instrument is suitable for the application for which it was originally purchased.

This warranty may become void if the Installation, Parameter Configuration & Setting Instructions are not carried out according to the instructions set out by CONTROL APPLICATIONS Ltd.

The ***ELNet*** Energy & Powermeter has no user serviceable parts and should be opened and serviced by a duly qualified authorized representative only. The sensitive electronics could become damaged if exposed to a static environment. This action would void the warranty.

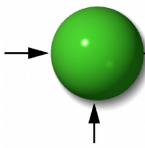

This warranty is limited to the repair and/or replacement at CONTROL APPLICATION Ltd sole discretion of the defective product during the warranty period. Repaired or replaced products are warranted for ninety (90) days from the date of repair or replacement, or for the remainder of the original product's warranty period, whichever is longer.

CONTROL APPLICATIONS Ltd is always at your service to advise the customer on any problem that may be encountered regarding any installation, operation, parameter & configuration settings or maintenance.

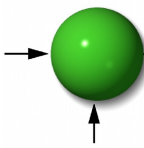

1.5 Your comments are welcome

CONTROL APPLICATIONS Ltd. sincerely thanks you for choosing our ***ELNet*** Energy & Powermeter. We are confident that it will provide you with many years of trouble free service and give you all the power and energy information and history that you expected from the instrument when you bought it.

While every effort was made to keep the information as reliable, helpful, accurate and up to date as possible, all possible contingencies cannot be covered. Technical or typographical errors could occur, and we would be happy to receive any comments, criticisms or notifications of any such errors from you, our valued customer.

Street Address: 24A HaBarzel St.
 Tel-Aviv 69710
 Israel
 Tel: +972-3-647-4998
 Fax: +972-3-647-4598

Electronic Address: cal@ddc.co.il

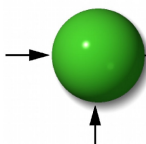

1.6 Disclaimer

Information in this User Manual is subject to change without notice and does not represent a commitment on the part of CONTROL APPLICATIONS Ltd.

CONTROL APPLICATIONS Ltd supplies this User Manual as is without warranty of any kind; either expressed or implied, and reserves the right to make improvements and/or changes in the manual or the product at any time.

While it is the intention of CONTROL APPLICATIONS Ltd to supply the customer with accurate and reliable information in this User Manual, CONTROL APPLICATIONS Ltd assumes no responsibility for its use, or for any infringement of rights of the fourth parties which may result from its use.

This User Manual could contain technical or typographical errors and changes are periodically made to the information herein; these changes may be incorporated in new editions of the publication.

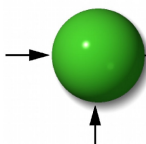

CHAPTER 2 — INSTALLATION

In this Chapter you will find the information and instructions that the *Installation Technician* needs, to mount and connect the ***ELNet*** Energy & Powermeter

WARNING!

- During operation, hazardous voltages are present in connecting cables and terminal blocks.
- Fully qualified personnel must do all work. Failure to follow this rule may result in serious or even fatal injury to personnel and/or damage to equipment.
- Refer to Section 1.3 Safety information before carrying out any installation.
- Read this manual thoroughly and make sure you understand the contents before connecting the ***ELNet*** Energy & Powermeter to any power source.

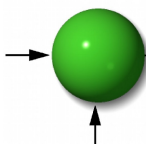

2.1 Contents of packaging

The **ELNet** Energy & Powermeter is packed and shipped in a carton approximately 24.5 cm long X 19 cm wide X 12 and cm high.

Before opening the package, ensure the area, clean and dry.

Without using any sharp instruments, carefully open the carton of the **ELNet** Energy & Powermeter.

Please check the contents of the carton, it should contain:

	Elnet GR	Elnet PQ
1.	Your new Elnet Energy & Powermeter	Your new Elnet Energy & Powermeter
2.	Elnet GR/PQ User Manual (this book)	Elnet GR/PQ User Manual (this book)
3.	Test Certificate and Certificate of Compliance (C.O.C).	Test Certificate and Certificate of Compliance (C.O.C).
4.	A pair of Panel mounting clips.	A pair of Panel mounting clips.
5.	1 X two pole connector plug.	2 X two pole connector plug.
6.	1 X three pole connector plug.	1 X Four pole connector plug.
7.	1 X Four pole connector plug.	1 X Five pole connector plug.
8.	1 X Five pole connector plug.	

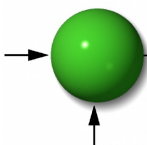

2.2 Mechanical mounting

To Mount the *ELNet* Energy & Powermeter

NOTE!

Do not mount the *ELNet* Energy & Powermeter too close to any main electrical conductors.

Allow sufficient space to carry out maintenance to the back of the *ELNet* Energy & Powermeter

Choose a suitable location, and prepare a rectangular hole according to the dimensions shown in Figure 2.1

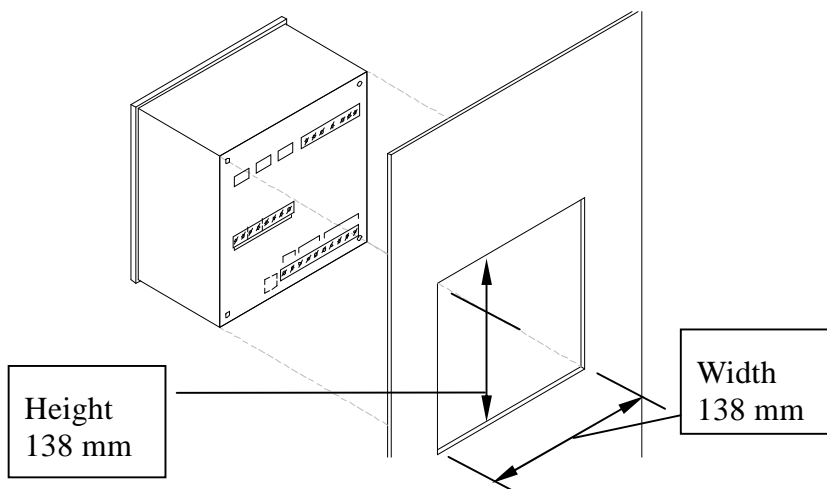
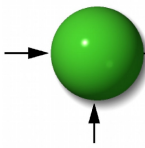

Figure 2.1. Panel Cutout



- Slide the **ELNet** Energy & Powermeter into the pre-prepared rectangular hole (ensure it is the right way up), then push the two mounting clips provided in the packaging into position. Use mild force to ensure the clips are securely positioned on the outer case of the **ELNet** Energy & Powermeter.
- Tighten the two mounting screws and ensure the **ELNet** Energy & Powermeter is firmly in place.

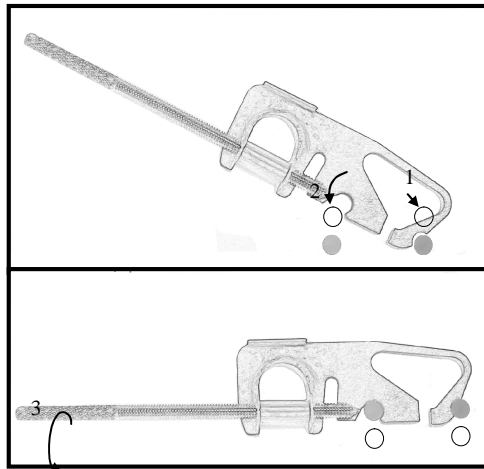
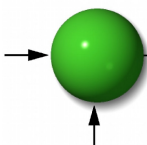

Figure 2.2. Mounting Clips



2.3 Wiring Schematics

To wire up the *ELNet* GR Energy & Powermeter in "Star" connection:

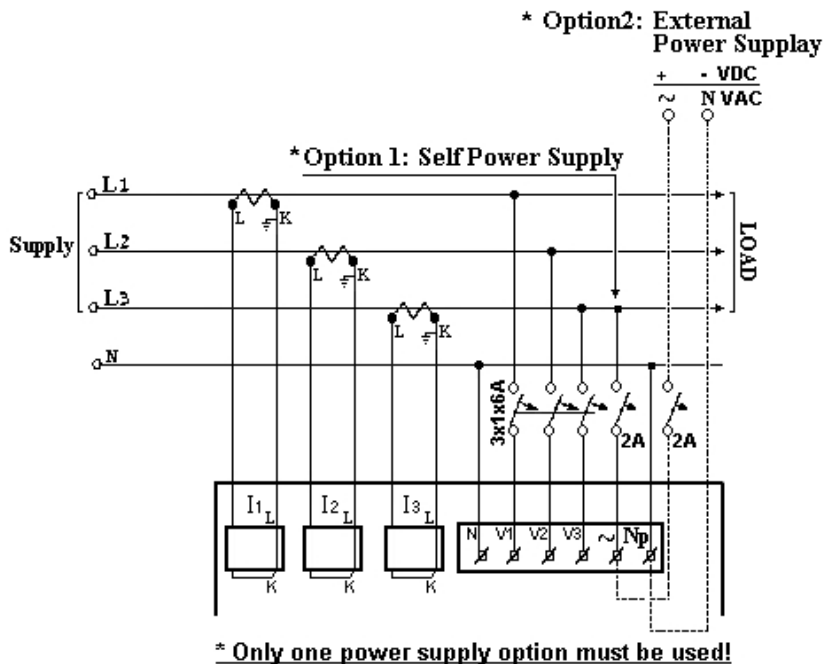
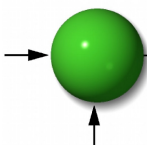

Figure 2.3. GR Schematic "Star" Wiring Diagram



To wire up the **ELNet** GR Energy & Powermeter in "Delta" connection:

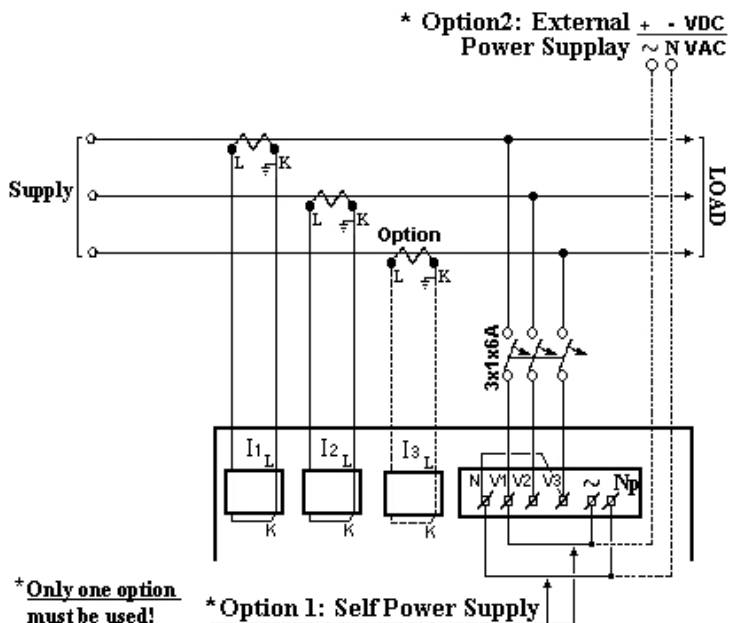
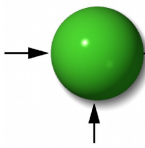

Figure 2.4. GR Schematic "Delta" Wiring Diagram



To wire up the *ELNet* PQ Energy & Powermeter in "Star" connection:

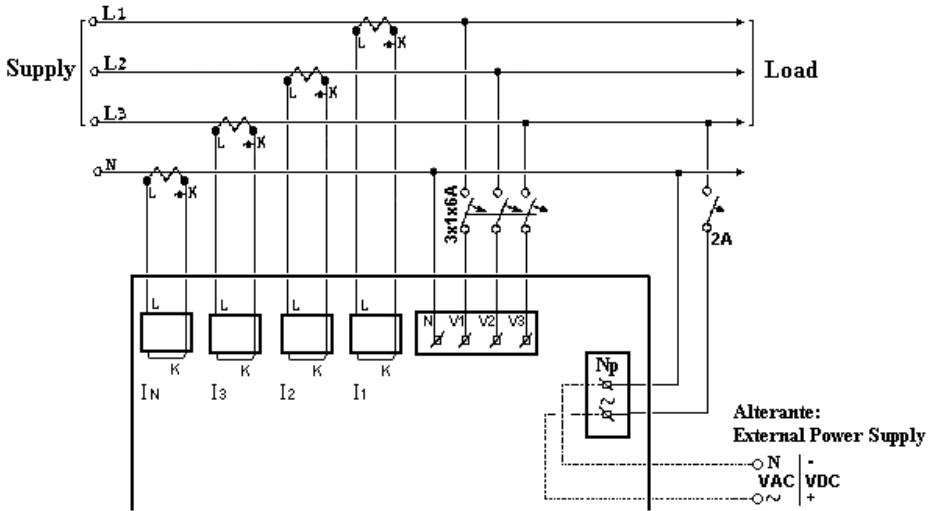
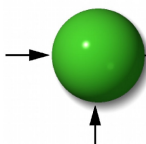

Figure 2.5. PQ Schematic "Star" Wiring Diagram



2.4 Rear Panel Connections

Please re-read section 1.3 for safety instructions.

To connect the Rear Panel

All Connections, except those to the CT core of the *ELNet* Energy & Powermeter are made via terminal connector plugs (Voltage input, Power Supply, Communication etc.).

Maximum recommended tightening torque for the connector screws is 0.5 Nm.

The CT cores of the *ELNet* Energy & Powermeter are located externally on the rear of the instrument and the lead from the leg of the external Current Transformer must pass through in the correct direction.

NOTE!

Ensure all the connections to the leads of the current transformer wiring are secure and there is no mechanical strain on the wire. The cross section of the leads to the current transformer must be compatible to the power of the current transformer. We recommend a power transformer with at least 3VA and the length of the wiring of the transformer no longer than 3m.

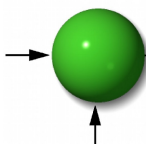

Insert the lead from side “**K**” of the Current Transformers of **Line 1** through the bottom of the CT core **I1A**, (top left looking from back), of the **ELNet** Energy & Powermeter.

- Ensure the leads from leg “**K**” of the Current Transformer on **Line 1** pass through the bottom of CT core **I1A**.
- Ensure the other end of the lead emerging from the top of C T core **I1A** is connected to leg “**L**” of the Current Transformer on **Line 1**

WARNING!

Never allow an open circuit between the two Current Transformers.

Repeat the procedure for **Line 2** and **Line 3** (In ELNet PQ repeat also for **Neutral Line IN**).

Connect the rest of the connections to the **ELNet** Energy & Powermeter by means of terminal connector plugs. The Rear Panel (See Figure 2.7.) has all connections printed and are simple to follow. (See table 2-1 for connections)

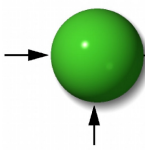

Supervision & control system

Tel: +972-3-6474998 Fax: +972-3-6474598 24a Habarzel St. Tel-Aviv, 69710, Israel

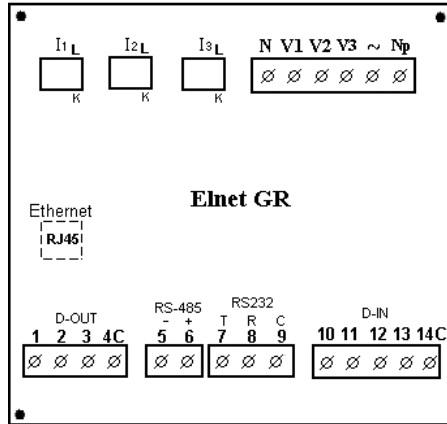

Figure 2.7. Rear Panel Elnet GR

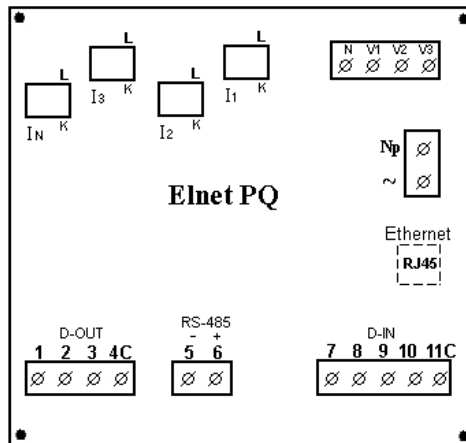
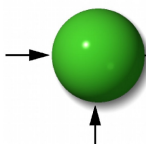
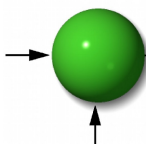

Figure 2.8. Rear Panel Elnet PQ



Pin Designation	Description	Remarks
V₁	Line1 Supplied Voltage	Through a 6Amp fuse
V₂	Line2 Supplied Voltage	Through a 6Amp fuse
V₃	Line3 Supplied Voltage	Through a 6Amp fuse
N	Neutral	Measurement neutral Line
I_{1A}	From Current Transformer on Line1	Note the correct direction to insert the lead
I_{2A}	From Current Transformer on Line2	Note the correct direction to insert the lead
I_{3A}	From Current Transformer on Line3	Note the correct direction to insert the lead
~	Power Supply 110 - 260 VAC	Or 110-260 VDC, external power supply or bridged from phase measurement
N_p	Neutral	Neutral of external power supply
Dout	Alarms, see chapter 5.6.1	
Din	For monitoring	



Pin Designation	Description	Remarks
RS485 — -	RS485 Comm. (-) Line	
RS485 — +	RS485 Comm. (+) Line	
RS232 — TXD	RS232 Comm. Transmit	GR model only
RS232 — RXD	RS232 Comm. Receive	
RS232 — COM	RS232 Comm. Common	
RJ45	10 BASE-T line to Network	Via standard Communications plug

Table 2-1 Rear Panel connections Elnet GR/PQ

2.5 Digital Outputs and Inputs.

ELNet GR/PQ Energy Powermeter & Power Quality Analyzer has as default 3 Digital Output and 5 Digital Input connections at its back side (additional IO can be implemented by using additional external modules).

Digital Output:

The Digital Output of the GR/PQ can be used to transmit pulses of energy to external BMS controller (chapter 4.6) or to close contact upon alarm (chapter 5.4.3) which can be defined in the GR/PQ (same output cannot be used for both simultaneously). The Digital Out closes contact of Relay between pins 1/2/3 to 4c, the maximum load is 1 Amp.

Digital Inputs:

In order to change the status of the Digital Inputs of the GR/PQ a 220 VAC contact must be provided. The indication voltage should be supplied from one of the measured phases. The digital inputs status can be monitored by communication.

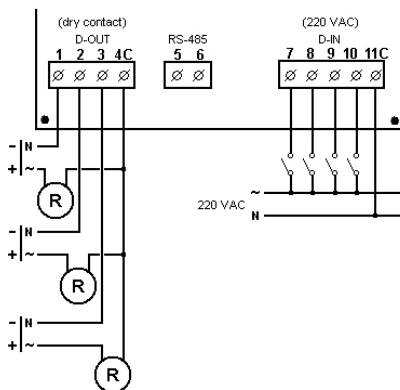
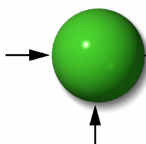

Figure 2.9 Digital In \ Digital Out wiring example



2.6 Manufacturing Data.

Press F1 on the keyboard for 6 seconds. The following screen will appear.

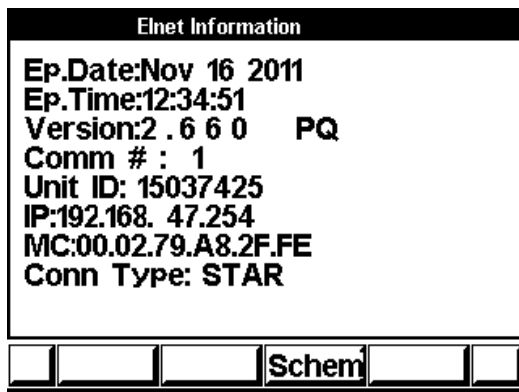

Figure 2.10. **Elnet Information**

Number	Screen	Description
1	Ep. Date	Production date of software operating system
2	Ep. Time	No. of times the program has been updated
3	Version	Program version no.
4	Comm #	Address of MODBUS Protocol
5	Unit ID	Consecutive calibration no.
6	IP	Ethernet/IP address
7	MC	Ethernet/MAC address
8	Conn Type	Connection type Star/Delta

Table 2-2 **Production Data**

CHAPTER 3 — USING THE *ELNet* Meter

In this chapter you will find descriptions and functions of the front panel and the control buttons and how to use them.

3.1 Front Panel

To operate the front panel

The Front Panel has a graphic screen and 6 operating buttons.

All the readings are shown on a state of the art 160 X 128 resolution graphic screen and are explained in detail in Chapter 5.

The Control Buttons and their functions are fully explained in Section 3.2.



Figure 3.1. **Front Panel**

3.2 Control Buttons

To operate the Control Buttons on Front Panel

The **ELNet** Energy & Powermeter has six Control Buttons. With these buttons the user can achieve all the functions necessary.

The Control Buttons are arranged on a keypad below the display screen and require slight finger pressure to click.

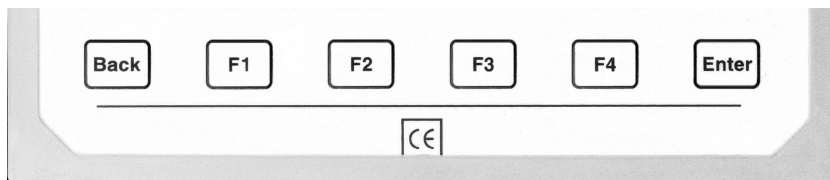







Figure 3.2. Control Buttons

Button		accepts the choice and executes the commands.
Button		performs the function that the arrow above is pointing to (e.g. move the cursor), or selects the prompt that the arrow is pointing to.
Buttons	  	performs exactly same actions as button F1.
Button		returns to the previous step or to the Main Menu.

3.3 Lock Utility

To lock and unlock the Control Buttons

The Control Buttons can be locked against any unauthorized or accidental usage.

Only sub menus can be locked. The Lock Utility does not work on the Main Menu.

To lock press “Enter” for six (6) seconds.

A “Keyboard Locked!” message appears on the screen when any button is pressed.

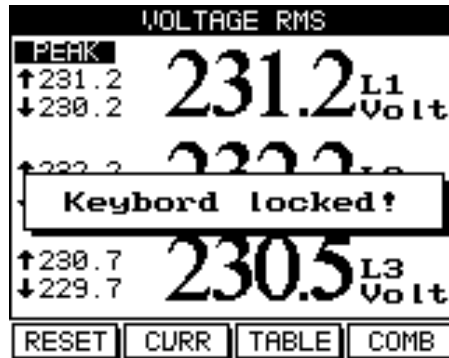
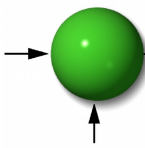

Figure 3.3. Keyboard locked



To Unlock simply press “Enter” for six (6) seconds.

A “Keyboard Unlocked!” message appears on the screen and normal functions can resume.

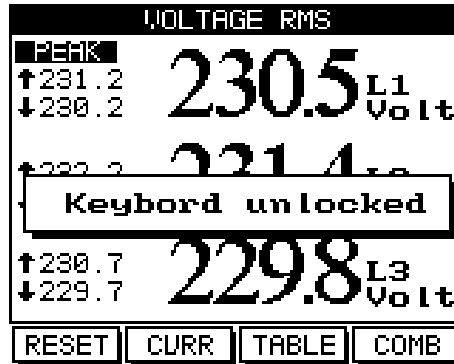
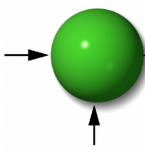

Figure 3.4. Keyboard Unlocked

NOTE!

In the event of a general power failure, the *ELNet GR* will return to the screen that was showing before the power failure occurred.



CHAPTER 4 — NECESSARY *ELNet* SETTINGS

In this chapter you will find instructions to set the minimum settings that are necessary to allow the *ELNet* Energy & Powermeter to function properly.

WARNING!

- The selection, installation and settings of the Current Transformer are the most vital and fundamental actions required to ensure the accuracy of the *ELNet* Energy & Powermeter.
- It is essential to know the ratio of the Current Transformer being installed into the system in order to set the parameter for the Current Transformer correctly.
- All three main current Lines **MUST** have Current Transformers of the same ratio installed onto them.

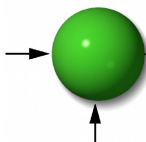

4.1 Settings for Current Transformer

To set or change settings for Current Transformer

NOTE!

The most important setting necessary for the proper functioning of the **ELNet** Energy & Powermeter is the Current Transformer setting.

The cross section of the leads to the current Transformer must be compatible to the power of the current transformer. We recommend a power transformer with at least 3VA and the length of the wiring of the transformer no longer than 3m.

- 1 From Main Menu scroll to **Technical Menu**.
- 2 Click "Enter" the **Check Password** screen appears.

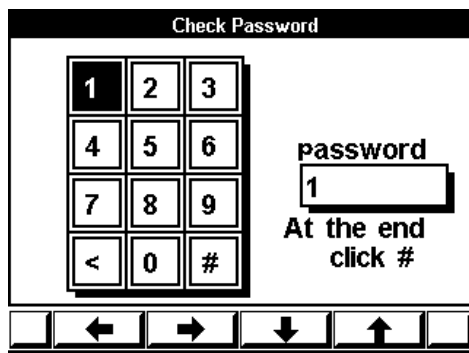
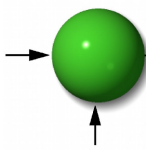

Figure 4.1. Check Password

The default password is: 1



- 3 Move the cursor with the F1, F2, F3, & F4 buttons to number 1. (See Section 3.2 for description of button functions).
- 4 Click "Enter", the number 1 will appear in the password field.

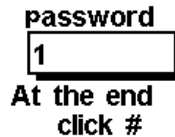

Figure 4.2. Password Field

- 5 Move the cursor to the # Sign with F1, F2, F3, & F4 buttons, (See Section 3-2 for description of button functions).
- 6 If the incorrect password is inserted into the Password field, an Error message appears.

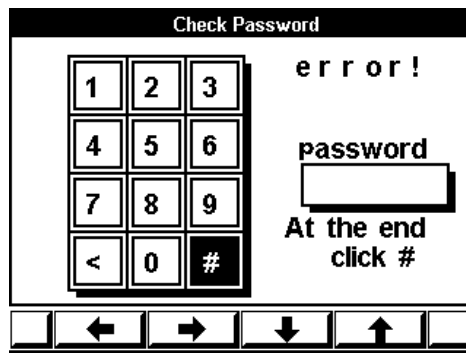
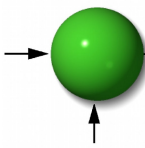

Figure 4.3. Error Message

- 7 Return to step 3 and start again.



- 8 Click “Enter” the **Technical Menu** screen appears.

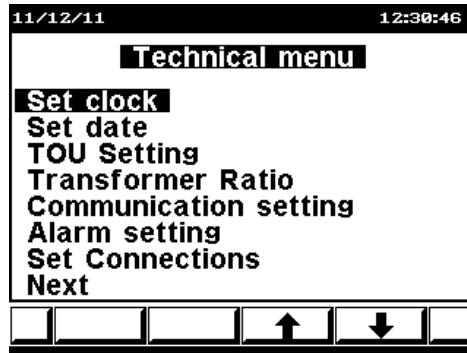

Figure 4.4. Technical Menu

- 9 Scroll to **Transformation Ratio**.
- 10 Click “Enter” The **Current Transformer** screen appears.

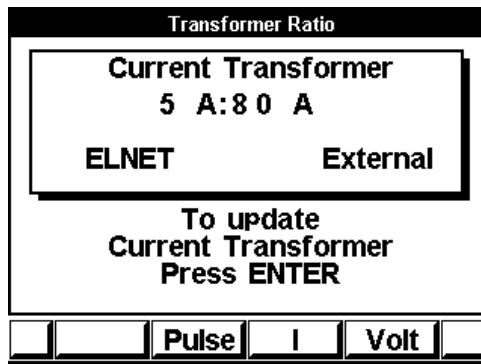
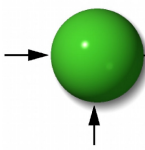

Figure 4.5. Current Transformer

The present setting for the **Current Transformer** is shown.
If it is a new installation, the ratio will show 5 A:5 A .



- 11 Click “Enter”, the **Insert Value** screen appears.

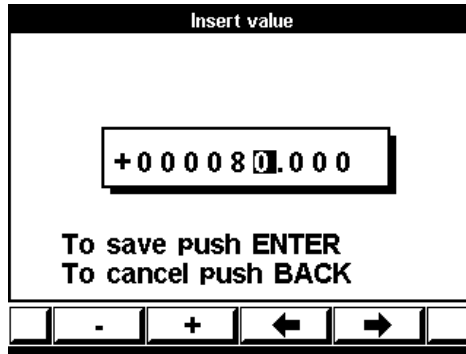

Figure 4.6. **Insert Value**

- 12 Use Button “**F3**” or “**F4**” to move the cursor left or right and Button “**F1**” or “**F2**” to decrease or increase the value + or -.
- 13 To save Click “Enter”.
- 14 To cancel Click “Back”.

4.2 **Electrical Connection Check**

NOTE!

To avoid any problems arising from incorrect Voltage Connections or accidental reversal of Current Transformer Connections, it is necessary to perform a Phase Order Check before continuing.

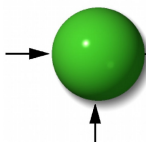

To perform Electrical connection Check

- 1 Scroll to "Technical menu" and press "Enter".
- 2 Insert password 11 in the password menu (check chapter 4.1 for explanation of how to set password).
- 3 The **Connection Check** screen appears.

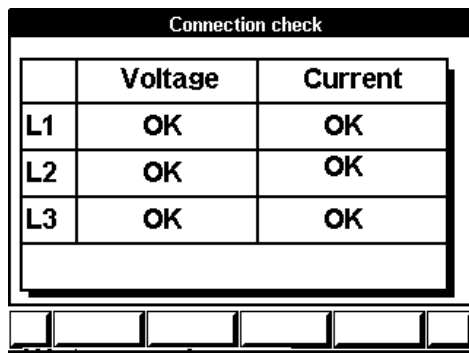
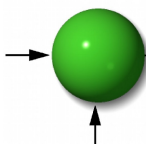

Figure 4.7. **Connection Check**

Voltage and Current Messages

Message	Voltage	Current
OK	Voltage "OK" present on Lines. If "OK" is not present on 3 Lines, then its not connected correctly	Current present in Lines <u>and</u> synchronized with Voltage Lines. If "OK" is not present on 3 Lines, then its not connected correctly
OPP	Not Applicable	Wired in incorrect direction
NO	No Voltage	No current

Table 4-1 **Voltage and Current Messages**



Phase Order Messages

Message	Voltage
OK	Correct Phase Order of Voltage Connections
OPP	Incorrect Phase Order i.e. Line 2 does not follow Line 1 and/or Line 1 does not follow Line3

Table 4-2 **Phase Order Messages**

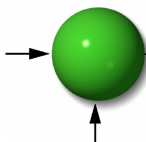

4.3 TOU Setting

ELNet Energy & Powermeter is capable of working in several TOU Settings. The user can choose the TOU Setting according to the country requested.

To set TOU

See Section 4.1 for instructions to arrive at the **Technical Menu**

From Technical Menu scroll to **TOU Setting** Click “Enter”.

The **TOU Setting** screen appears.

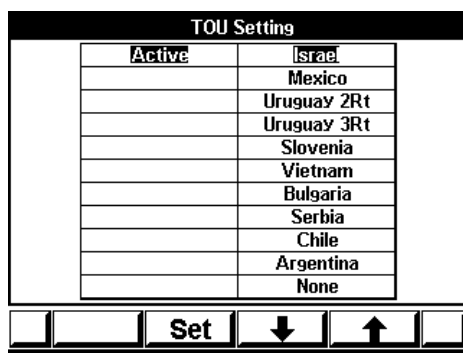
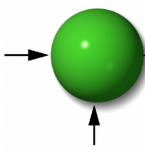

Figure 4.8. TOU Setting

Then scroll to the relevant country and press on the “Set” button, “Active” will appear next to the country name.

To exit from that screen press on “Back” or “Enter” button.



4.4 Change language

To change language on the display screen

- 1 On the main screen click “F2” for 6 seconds.
- 2 The Select language screen appears.

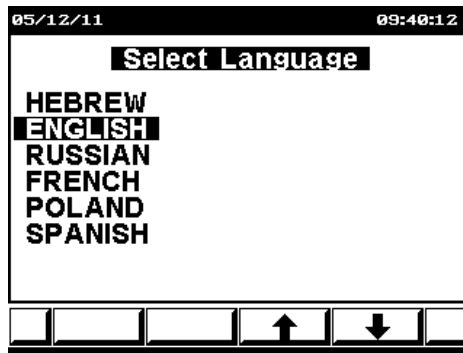
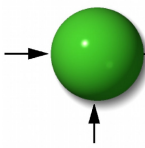

Figure 4.9. Select Language.

- 3 Scroll to the relevant language.
- 4 To save Click “Enter”.
- 5 To cancel Click “Back”.



4.5 Time Settings

To set Time

See Section 4.1 for instructions to arrive at the **Technical Menu**.

- 1 From Technical Menu scroll to Set Clock.
- 2 Click "Enter" The Set Clock screen appears.

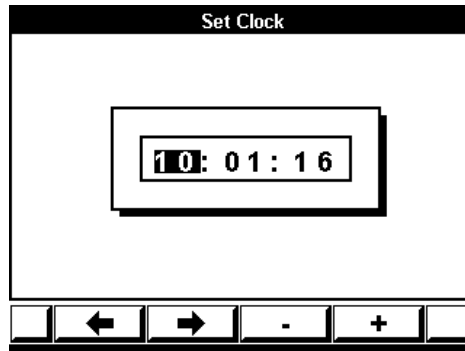
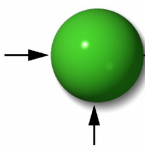

Figure 4.10. Set Clock

- 3 Use "F1" or "F2" buttons to select Hour, Minute, Second.
- 4 Use "F3" or "F4" to change time.
- 5 Use "Back" to return to Technical menu.



4.6 Date Settings

To set Date

See Section 4.1 for instructions to arrive at the **Technical Menu**.

- 1 From Technical Menu scroll to **Set Date**.
- 2 Click “Enter” The **Set Date** screen appears.

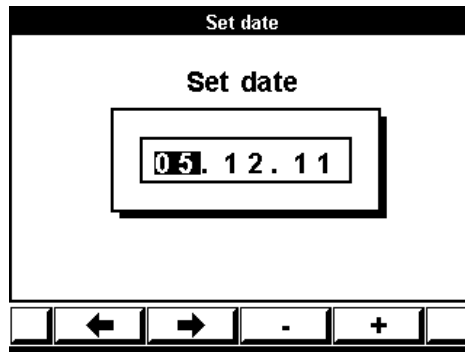
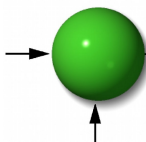

Figure 4.11. **Set Date**

- 3 Use “F1” or “F2” to select Day, Month, Year.
- 4 Use “F3” or “F4” to change Day, Month, Year.
- 5 Use “Back” to return to **Technical menu**.



4.7 Setting digital out

The digital output (chapter 2.5) can be used as an alarm, pulse, time table or trip (PQ only) output, in order to set the digital output - See section 4.1 for instructions to arrive at the **Technical Menu**.

From Technical Menu:

- 1 Scroll to **Next** and click “ENTER”
- 2 Scroll to **Digital Out Setup** and click “ENTER”
- 3 The **Digital Out Setup** screen appears.

Digital Out SetUp			
##	1	2	3
Alarm	+	+	+
Pulse	-	-	-
T.Tbl	-	-	-
Trip	-	-	-
Opt	-	-	-
Test	-	-	-

Navigation icons: +, →, ↓, ↑

Figure 4.12. **Set Digital Out**

- 4 Use “F2”, “F3” or “F4” to scroll to the relevant mode and digital out number.
- 5 Use “F1” for set the mode.

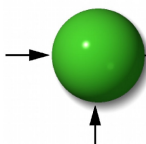

4.8 Delta/Star Electrical network definition

The *ElNet GR/PQ* can be installed in two types of electrical networks: DELTA – a system without neutral line.

STAR – a system with neutral line.

In order to change the type of the electrical network definition in the Elnet GR/PQ, see section 4.1 for instructions how to arrive at the **Technical Menu**.

- 1 From Technical Menu scroll to "**Set Connections**" and Click "ENTER".
- 2 The **Connection** screen appears.

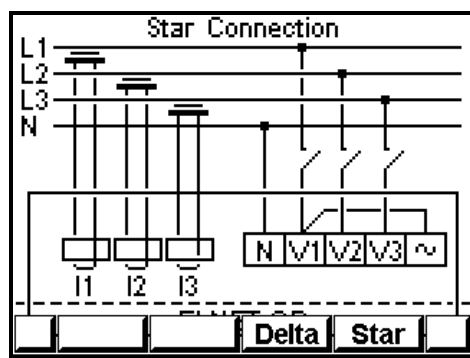
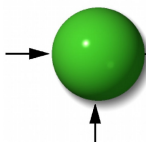

Figure 4.13 Delta/Star Connection

- 3 Use "F3"/ "F4" in order to change the connection type. When you are using "DELTA" networks the currents (line currents) and the voltages (between phases) are not in the same phase therefore part of the measurements are not applicable and part of the display screens are not applicable.



4.9 Demand Setting.

The **EINet GR/PQ** can determine the demand cycle time.

In order to change the cycle time connected to the Elnet GR/PQ
See Section 4.1 for instructions to arrive at the Technical Menu.

- 1 From Technical Menu scroll to "**Next**" and Click "Enter".
- 2 Scroll to "**Demand Setting**" and Click "Enter".
- 3 The **Demand Setting** screen appears.

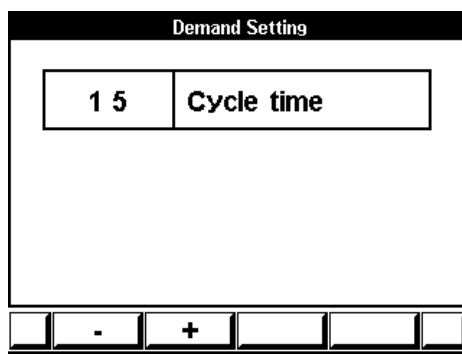
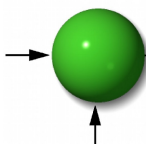

Figure 4.14 **Demand Setting**

- 4 Use "F1"/ "F2" in order to change the cycle time. The cycle steps are: 1, 2, 3, 4, 5, 10, 15, 20, 30 and 60 minutes.
- 5 Click "Enter" for saving the change.



CHAPTER 5 — FRONT PANEL DISPLAYS

In this chapter you will find instructions on how to obtain the readings that the ***ELNet GR/PQ*** Electrical Measurements & Power Quality provides, e.g., Current, Voltage Power, Power Factor, Energy, and Power quality.

5.1 Current for 3 Phases

To display Current for all 3 Phases

- 1 From Main Menu scroll to **Current & Voltage**.
- 2 Click “Enter” The **RMS Current** screen appears.

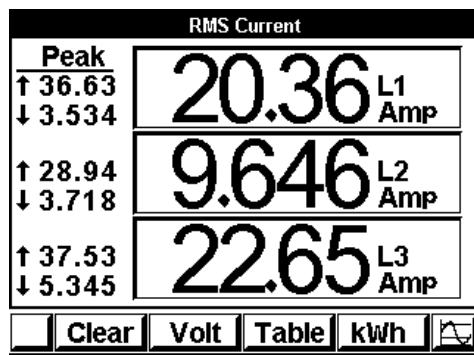
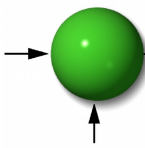

Figure 5.1. Current Display

- 3 Read the **Current for Line1, Line2 and Line3**.
- 4 In order to view the readings in online graphical



mode press on the "Enter" button.



- 5 The online graphical data screen appears.

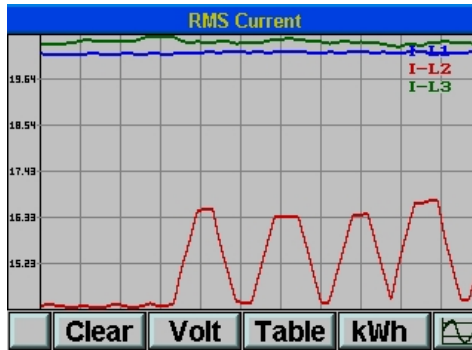

Figure 5.2. Current graphic Display

5.2 Frequency for 3 Phases

To display Frequency for all 3 Phases

- 1 Display the current screen as described in section 5.1.
- 2 Click "F3" - "TABLE".
- 3 Click "F3" - "Hz".

The **Frequency** screen appears.

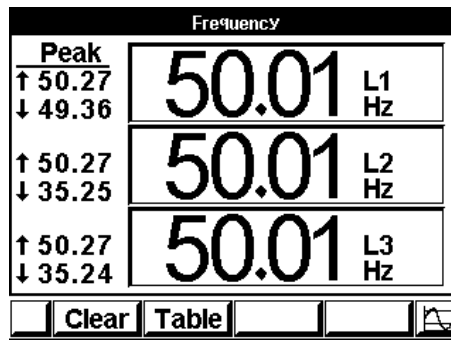
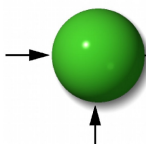

Figure 5.3. Frequency for all 3 Phases



- 4 In order to view the readings in online graphical



mode press on the "Enter" button.

You can reset the Peak values by using the "CLEAR" button.

Read the **Frequency** in Line 1, Line 2, Line3

5.3 Current in Neutral Line

ELNet GR - By using the Vector value of L1/2/3 **Current Lines** calculates the Current in the **Neutral Line**.

ELNet PQ – measures the **Neutral Line** current via additional current transformer.

If the reading for neutral line is "0" (i.e. there is no current in the neutral line), then either there is no current in system,

OR

the current for all three phases is balanced.

To display Current in the Neutral Line:

- 1 From Main Menu scroll to **Current & Voltage**.
- 2 Click "Enter" the **Current & Voltage** screen appears as described in section 5.1.
- 5 Click "F3" - "TABLE".

6 The **Current & Voltage** table screen appears.

Current & Voltage			
	Volt	Current	
L 1	228.4 V	21.73	A
L 2	229.6 V	9.560	A
L 3	229.8 V	21.31	A
L 1 2	398.2 V	Current Line 0	
L 2 3	397.4 V		
L 1 3	395.8 V		
		0.811	A

← Current in Neutral line

Figure 5.4. Combined Displays

5.4 Voltage for 3 Phases

To display Voltage for all 3 Phases and across Phases

- 1 From the Main Menu scroll to **Current & Voltage**.
- 2 Click “Enter” The **Current & Voltage** screen appears.
- 3 Click “F2” - “VOLT”, The **Voltage** screen appears

RMS Voltage	
Peak ↑ 237.5 ↓ 225.7	228.2 L1 Volt
↑ 236.9 ↓ 225.6	229.3 L2 Volt
↑ 237.7 ↓ 226.6	229.6 L3 Volt
<input type="button" value="Clear"/> <input type="button" value="I"/> <input type="button" value="Table"/> <input type="button" value="V L-L"/> <input type="button" value="V L-N"/>	

Figure 5.5. Voltage Displays

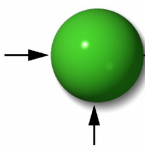

Parameter	Description	Units
L1	Voltage from Line1 to Neutral	Volts
L2	Voltage from Line2 to Neutral	Volts
L3	Voltage from Line3 to Neutral	Volts
L12	Voltage across Line1 and Line2	Volts
L23	Voltage across Line2 and Line3	Volts
L13	Voltage across Line1 and Line3	Volts

Table 5-1 Voltage Readings

5.5 Active Power for all 3 Phases (P)

To display Active Power for all 3 phases.

- 1 From Main Menu scroll to **Power Display**.
- 2 Click "Enter" The **Active Power** screen appears.

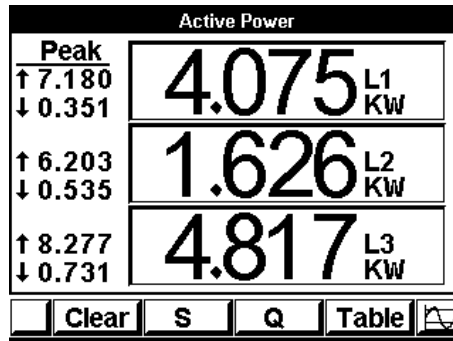
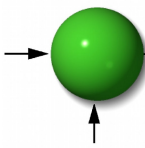

Figure 5.6. Active power



Peak \uparrow is the highest value reached for the adjacent reading since the ***ELNet*** Energy & Powermeter was first switched on,

OR

Since the last time the reset button was pressed.

Peak \downarrow is the lowest value reached for the adjacent reading since the ***ELNet*** Energy & Powermeter was first switched on,

OR

Since the last time the reset button was pressed.

The "CLEAR" button resets the Peak values only for the screen presently being shown.

5.6 Reactive Power for all 3 Phases (Q)

To display Reactive Power for all 3 phases

- 1 From Main Menu scroll to **Power Display**.
- 2 Click “Enter”, the **Active Power** screen appears (Figure 5.5).
- 3 Click “F3”, the **Reactive Power** screen appears.

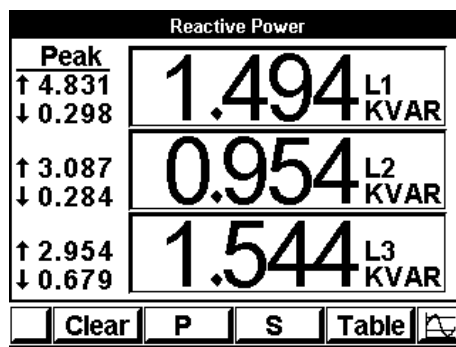

Figure 5.7. Reactive Power

Refer to section 5.4 for description of peaks.

The “CLEAR” button resets the Peak values.

- 4 In order to view the readings in online graphical



mode press on "Enter" button.

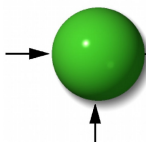

5.7 Apparent Power for all 3 Phases (S)

To display Apparent Power for all 3 phases

- 1 From Main Menu scroll to **Power Display**.
- 2 Click “Enter”, the **Active Power** screen appears (Figure 5.5).
- 3 Click “F2” The **Apparent Power** screen appears.

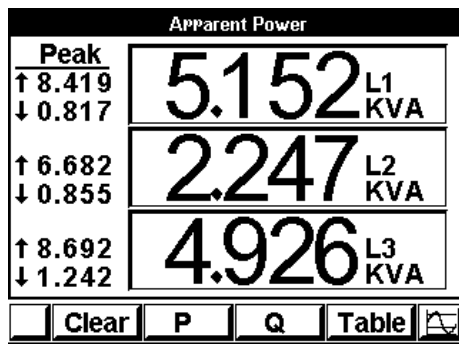

Figure 5.8. Apparent Power

Refer to section 5.4 for description of peaks.

The “CLEAR” button resets the Peak values.

- 4 In order to view the readings in online graphical



mode press on "Enter" button.

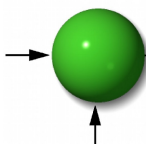

5.8 Power Factor for each Phase

To display Power Factor for each phase

- 1 From Main Menu scroll to **Power Display** and click “Enter”.
- 2 Click “F3” to display “TABLE” format. The **Power Table** screen appears.

Power display			
Power units: KW/KVAR/KVA			
L	P	Q	S
1	4.659	1.805	4.997
2	3.640	1.754	4.040
3	5.158	1.810	5.467
Σ	13.46	5.369	14.50
PF = 0.928			

P	Q	S	PF
---	---	---	----

Figure 5.9. Power Table

Parameter	Description	Unit
P	Active Power for each Line	Watts
Q	Reactive Power for each Line	VAR
S	Apparent Power for each Line	VA
P	Total Active Power for all 3 Lines	Watts
Q	Total Reactive Power for all 3 Lines	VAR
S	Total Apparent Power for all 3 Lines	VA
PF	Overall Power Factor	

Table 5-2 Power Readings

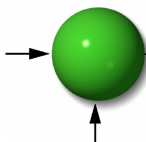

- 3 Click “F4” – “PF” The **Power Factor** for each Line screen appears.

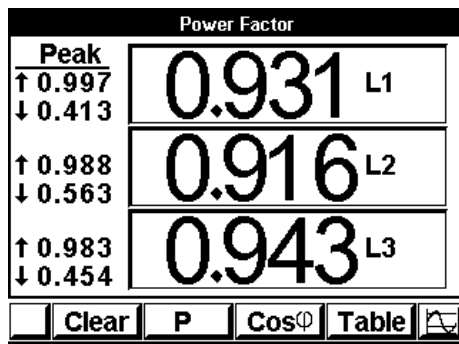

Figure 5.10. Power Factor for each line

5.9 Overall Power Factor

To display Overall Power Factor

- 1 From Main Menu scroll to **Power Display**
- 2 Click “Enter” and then click “F4”.
- 3 The **Power Table** screen appears.

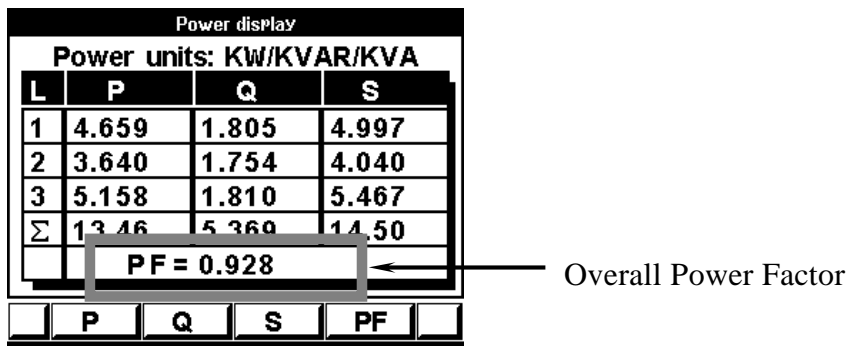
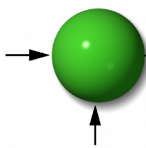

Figure 5.11. Power Table



5.10 Active/ Reactive/ Apparent Energy

To display Overall Active/Reactive/Apparent Energy

- 1 From Main Menu scroll to **Energy Display**.
- 2 Click “Enter”, the **Energy Meter** screen appears.

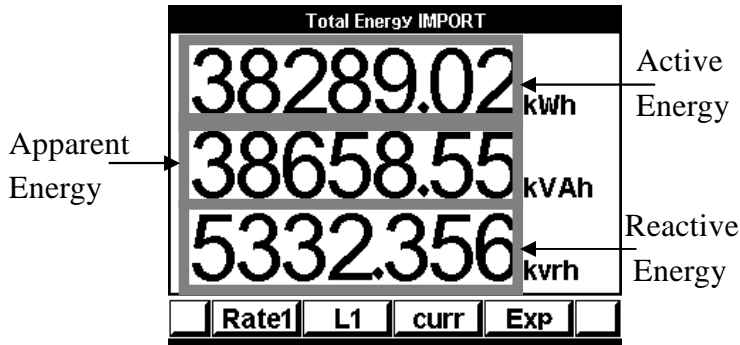
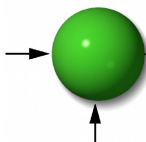

Figure 5.12. Energy Meter

- 3 Click “F1” to read **Energy in each Rate** at Rate1, Rate 2 and Rate3.
- 4 Click “F2” to read **Energy at Phase** at Line1, Line2 and Line 3.
- 5 Click “F4” to read **Export/Import Energy**.
- 6 To return to Main Menu click “Back”.



5.11 Power Quality

Poor Harmonics could invoke a fine and damage to the electrical system and can be improved by adding filters.

The **ELNet** Energy & Powermeter **GR** Model is capable of displaying Harmonics in **Wave Form Graph, Harmonics Bar Graph, Harmonic Tables** and **Total Harmonic Distortion** for Voltage and Current.

5.11.1 Wave Form Graphs

To display Wave Form Graphs

- 1 From Main Menu scroll to Power Quality.
- 2 Click "Enter", the **Power Quality** screen appears.

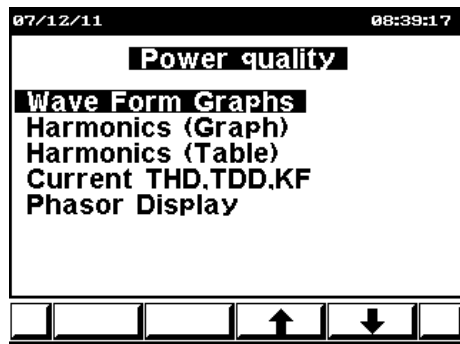
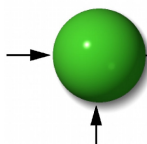

Figure 5.13. Power Quality

- 3 Scroll to **Wave Form Graphs**.



- 4 Click “Enter”, the **Wave Form Graphs** screens appear.

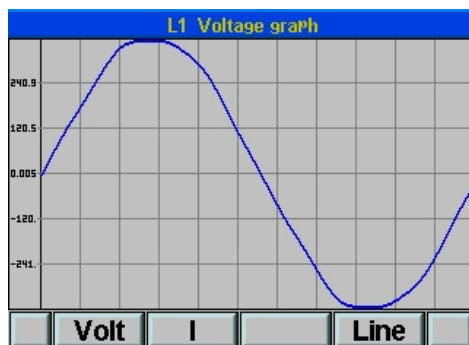

Figure 5.14. **Voltage Graph**

- 5 Press “F4” to switch between **Voltage Graph** Line 1, Line 2 and Line 3.

To display Current Wave Form Graphs

- 1 Click “F2”, the **Current Graph** screens appears.

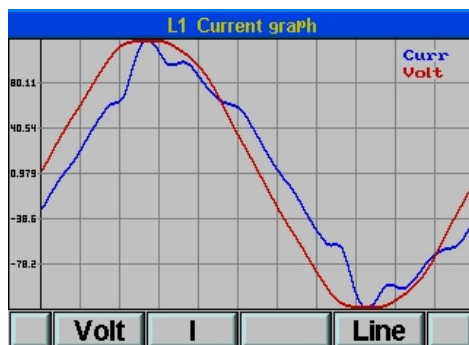
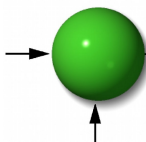

Figure 5.15. **Current Graph**

- 2 Press “F4” to change between the **Current Graph** Line 1, Line 2 and Line 3.



5.11.2 Harmonics Bar Graphs

To display Harmonics Bar Graphs

- 1 From Main Menu scroll to **Power Quality Display**.
- 2 Click “Enter”, the **Power Quality** screens appears (Figure 5.14).
- 3 Scroll to **Harmonic (Graphs)**.
- 4 Click “Enter”, the **Harmonics Volt Bar Graph** screens appears.

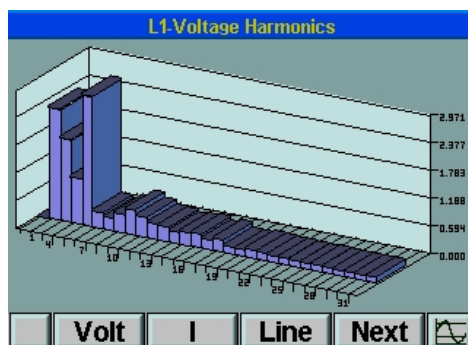
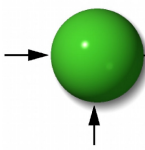

Figure 5.16. **Harmonics Bar Graph**

- 5 Press “F3” to change **Harmonics Volts Bar Graph** to Line 1, Line 2, Line 3 and Lines 1,2,3 together.

1st Harmonics is normally 100%. If shown together with the other Harmonics, distortion to the rest of the Harmonic Bar Graph will occur. By toggling “F4”, the **ELNet** Energy & Powermeter is able to separate 1st Harmonics to prevent this distortion.



To display Harmonics Current Bar Graph

- 1 Click “F2”, the **Harmonic Current Bar Graph** screens appears.

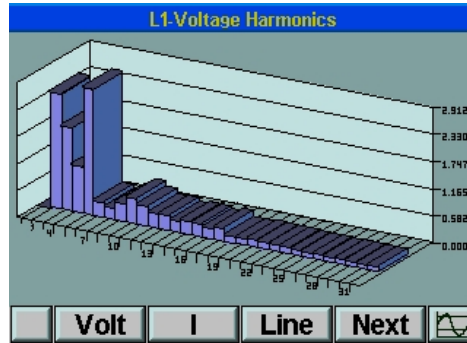
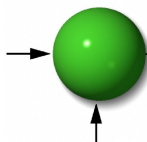

Figure 5.17. **Harmonic Current Bar Graph**

- 2 Press “F3” to change **Harmonics Current Bar Graph** to Line 1, Line 2, Line 3, Neutral Line (L0) and Lines 1,2,3 together.



5.11.3 Voltage Total Harmonic Distortion (THD).

The *ELNet* Energy & Powermeter is capable of measuring Voltage and Current Harmonic Distortion for the first 64th Harmonics. These are presented in a table format with the Total Harmonics Distortion (THD) also shown.

To display Harmonics Tables

- 1 From Main Menu scroll to **Power Quality** Display.
- 2 Click “Enter”, the **Power Quality** screens appears.
- 3 Scroll to **Harmonic (Table)**.
- 4 Click “Enter”, the **Harmonics Volt Table** screens appears.

L1-Voltage Harmonics			
##	Value %	##	Value %
1	100.0	9	0.606
2	2.075	10	0.340
3	1.465	11	0.246
4	0.853	12	0.279
5	2.673	13	0.252
6	0.320	14	0.254
7	0.442	15	0.307
8	0.385	16	0.178

Figure 5.18. **Harmonic Volt Table**

- 5 Click “F4” to scroll down the Table to observe all Volt Harmonics till 60th.
- 6 Click “F3” to change **Harmonics Volt Table** to Line 1, Line 2, Line 3 and Lines 1,2,3 together.

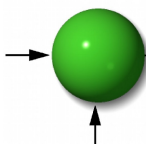

5.11.4 Current Total Harmonic Distortion (THD)

To display Harmonics Current Table

- 1 Repeat steps 1-4 from Section 5.13.3.
- 2 Click “F2” The **Harmonic Current Table** screens appears.

L1-Current Harmonics			
##	Value %	##	Value %
1	100.0	9	4.525
2	2.443	10	1.651
3	5.623	11	2.795
4	0.549	12	0.631
5	3.556	13	1.119
6	0.801	14	0.419
7	1.165	15	0.422
8	0.682	16	0.582

Figure 5.19. **Harmonic Current Table**

- 3 Click “F4” to scroll down the Table to observe all the Current Harmonics till 60th.
- 4 Click “F3” to change **Harmonics Current Table** to Line 1, Line 2, Line 3, Neutral Line (L0) and Lines 1,2,3 together.

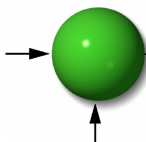

5.11.5 Current THD,TDD,KF

- 1 From Main Menu scroll to Power Quality Display and Click “Enter”.
- 2 Scroll to THD, TDD, KF Current.
- 3 Click “Enter“, the **Current, THD, TDD, KF** Table screens appears.

Current THD,TDD,KF			
L	THD%	TDD%	KF
1	13.63	0.363	0.934
2	19.69	0.325	1.017
3	19.28	0.476	1.139
0	21.82	0.018	1.018
I .MAX = 1000			

I.Set

Figure 5.21. **Current THD, TDD, KF**

- 4 In order to enable the system to calculate properly the TDD value, user should set the max line current value by using “F4”.

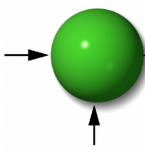

5.11.6 EN50160 event monitoring and Wave records

When a power quality event occurs (as specified in the EN50160 standard), Elnet PQ stores the record of it in its memory. This record can be downloaded to the PC later on for detailed analyze.

Before starting the EN50160 events record mode, the nominal voltage range must be defined:

- 1 Access the **Technical Menu** (see chapter 4.1).
- 2 Scroll to **Next** and click "Enter".
- 3 Scroll to **PQ Parameters** and click "Enter".
- 4 The **PQ Parameters** screen appears.

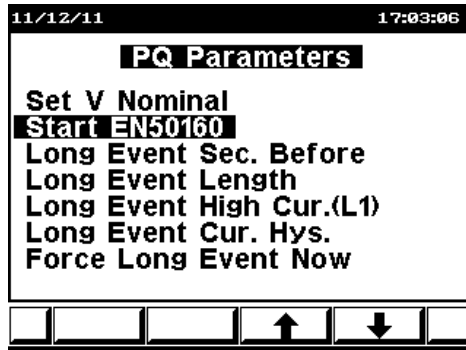
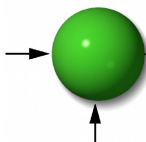

Figure 5.22. PQ Parameters.

- 5 Scroll to **Set V Nominal**.



- 6 Click “Enter”, the **Set V Nominal** screen appears.

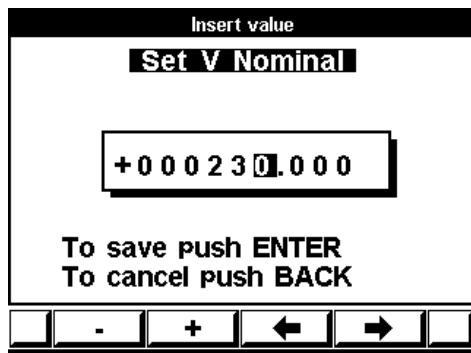

Figure 5.23. **Set V Nominal**

- 7 Use button “**F3**” or “**F4**” to move the cursor left or right and Button “**F1**” or “**F2**” to decrease or increase the value + or -.

In order to start the EN50160 mode:

- 8 To activate the EN50160 mode, scroll to **Start EN50160** and click “Enter”.
- 9 The line will change to **Stop EN50160**.

When in the line written STOP EN50160, it means that EN50160 is Active.

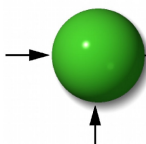

5.11.7 Long PQ event special record

Most of the power quality events as specified in the EN50160 standard occur in a very short time periods (less than a second). If a demand to make a special (not according to EN50160) and long record (several seconds) exists the following definitions must be done:

- 1 Activate the EN50160 mode by repeating the steps from chapter 5.11.6.
- 2 Scroll to **Long Event Length**.
- 3 Click "Enter", the **Long Event Length** screen appears.

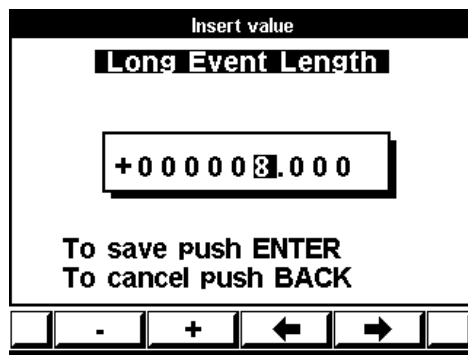
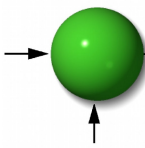

Figure 5.24. **Long Event Length**

- 4 In order to set the value in seconds (recommended is no more than 8 seconds) use button "F3" or "F4" to move the cursor left or right and Button "F1" or "F2" to decrease or increase the value + or -.



If a demand to start the record a few seconds before the long event begins:

- 1 Repeat on steps 1 to 4 from chapter 5.11.7.
- 2 Scroll to **Long Event Sec. Before**.
- 3 Click "Enter" the **Long Event Sec. Before** screen appears.

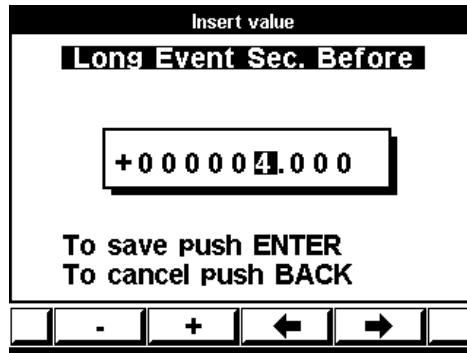

Figure 5.25. Long Event Sec. Before

- 4 Use button "F3" or "F4" to move the cursor left or right and Button "F1" or "F2" to decrease or increase the value + or -.

There are 3 triggers to start the special long record:

4.1. Changes in current of Line 1:

- 1 Repeat on steps 1 to 4 from chapter 5.11.7.
- 2 Scroll to **Long Event High Cur. (L1)**.
- 3 Click "Enter", the **Long Event High Cur. (L1)** screen appears.

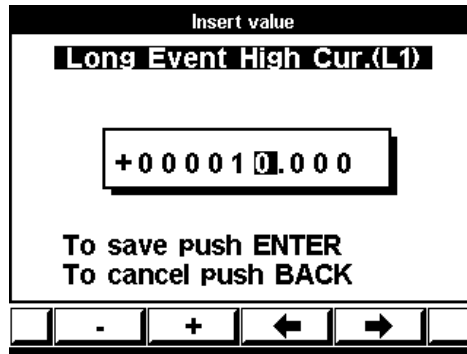
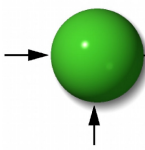

Figure 5.26. Long Event High Cur. (L1).

- 4 Set the high current value that will start the special record by using button “F3” or “F4” to move the cursor left or right and Button “F1” or “F2” to decrease or increase the value + or -.

Setting hysteresis value in line 1 to return to normal and reset for new event.

- 5 Repeat on steps 1 to 4 from chapter 5.11.7.
- 6 Scroll to **Long Event Cur. Hys.**
- 7 Click "Enter", the **Long Event Cur. Hys.** screen appears.

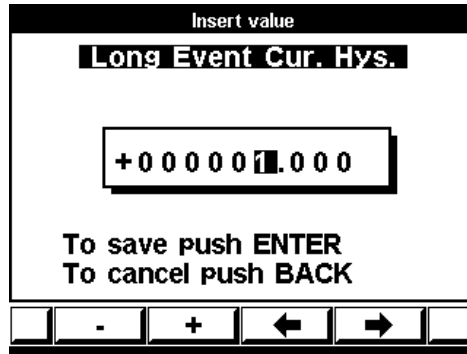
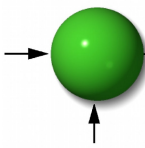

Figure 5.27. Long Event Cur. Hys.

- 8 Set the low current value that will stop the special record by using button “F3” or “F4” to move the cursor left or right and Button “F1” or “F2” to decrease or increase the value + or -.

4.2. Activating by communication

- 1 Writing value of "1" to Modbus register 1299-1300.
(Check Chapter 9 Communication).

4.3. Activating from PQ menus

- 1 Repeat on steps 1 to 4 from chapter 5.11.7.
- 2 Scroll to **Force Long Event Now**.
- 3 Click “Enter” to start recording.

CHAPTER 6 — ALARM REPORT

Every second automatically the **ELNet** monitors all the electrical values and compare them to the pre-setting alarm values.

The **ELNet** can handle and store up to 1,000 alarms in the **ELNet** memory with their time & date data.

The **ELNet** has three alarm relays, each one of them can be linked to one or more pre-defined alarms.

The following alarms can be defined:

	<u>Lines</u>
1. Voltage alarms	L1; L2; L3
2. Current alarms	L1; L2; L3 + Neutral line
3. Active Power (Kw)	L1; L2; L3 + 2 Total
4. Power factor alarms	L1; L2; L3 + General
5. Harmonics alarms	L1; L2; L3; L0

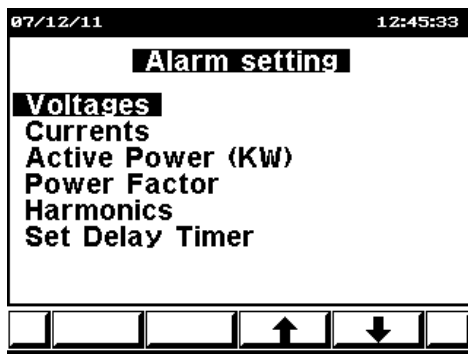
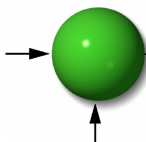

Figure 6.1. Alarm Setting

For each one of the above alarms the user can define two alarms - low value alarm and high value alarm.

The user can select one of sixteen different timers in order to delay each one of the alarms.



6.1. Alarm setting

See chapter No. 4.1 how to get in the **Technical Menu** from the main screen.

From the **Technical Menu** select “**Alarm setting**” and press Enter. The **Alarm Setting Screens** appear. (See figure 6.1).

From this screen you will be able to set alarms for Voltages, Currents, Active Power, Power Factor, Harmonics alarms and to set the values for 16 delay timers that can be linked to each one of the alarms.

For each alarm the user can define:

High alarm – The set point above which the alarm will be generated.

Low alarm – The set point below which the alarm will be generated.

Delay timer – One of sixteen timers that define the time duration that the alarm should be “ON” in order to be written in the memory.

Voltage L1		
Out Value	Alarm	
3	253.0	High Value
1	205.0	Low Value
T 2	Delay Timer	

Figure 6.2. Alarm user defines

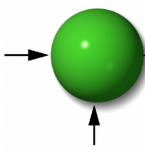

Set Delay Timers:

Up to sixteen delay timers can be defined in the **ELNet** Meter, user can link for each one of the timers one or more alarms, the delay timer will check that the alarm is stable and will not write the alarm in the memory of the **ELNet** unless the alarm is in “ON” position for the time duration as set.

In order to set the time duration for the sixteen timers select “**Set Delay Timer**” form the screen described in Figure 6.1. **Alarm Setting Screens** the following screen appears.

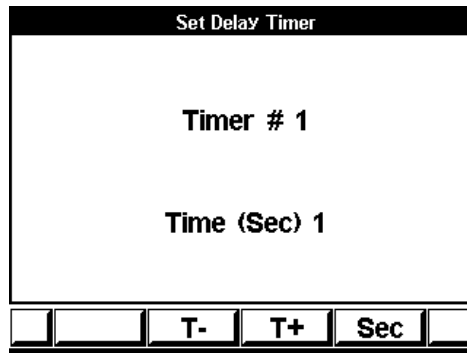
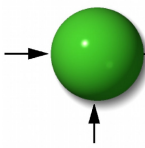

Figure 6.3. Timer Delay

By using “T- / T+ “(F2 / F3) the timer number can be changed.

By using “SEC “(F4) the time delay value can be changed.



6.2. Display Alarms Report

Two alarm reports can be generated:

Historical alarm report – includes all the information about fixed alarms (return to normal status).

Current alarm report - includes all the information about existing alarms.

- 1 In order to generate an alarm report, from the Main Menu scroll to “**Alarm report**“ and press “Enter”.
- 2 Scroll to “**Historical Repot**” or “**Current report**“ and select one of them by using “F3” or “F4” and press “Enter”. A list of alarms appear.
- 3 Press “INFO” (F1) in order to get detailed information. The following screen appears.

Alarm Details		
Low Power KW	-L0	
Alarm	14:10:28	08.12.11
OFF	-----	-----
Alarm Set Point		15.00
Measured Value <		14.90
Number Of Events :		1

Figure 6.4. Alarm Details

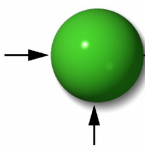

6.3. Display EN50160 Event Report

In addition to alarm reports, an EN50160 event report can also be generated.

- 1 In order to generate an event report, from the Main Menu scroll to “**Alarm report**” and press “Enter”.
- 2 Scroll to “**EN50160 Events**” and press “Enter”. A list of EN50160 events appear.
- 3 Press “Enter” in order to get detailed information. The following screen appears.

EN50160 Events	
Description	Value
Event	Voltage Transient
Phase	3
Date	10/09/2012
Time	07:03:09
MicroSecond	741000
V Nominal	230
Value	396
%	172.2
Length	0.00013
Event ID	23

--	--	--	--	--	--

Figure 6.5. EN50160 event Details

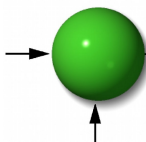

CHAPTER 7 — DEMAND REPORTS

ELNet Meter can generate reports that will inform the user the date of the maximum demand. The reports include:

Maximum Demand – for active power and power factor.

Maximum Demand – for reactive power and power factor.

Maximum Demand – for apparent power and power factor.

Maximum Demand – for current.

The **ELNet** informs the value of the demand and the relevant power factor, the time. The date, for all three phases, the demand is the maximum value within the predefine time interval specified by the user.

Press F1 in order to select I / PF - Current / power factor maximum Demand.

Press F2 in order to select P / Q / S active / reactive / apparent power Demand

Press F4 in order to see the power factor together with the power demand.

Press F3 “DATE” in order to change the time interval within which the **ELNet** will check the maximum demand.

CHAPTER 8 — DATA LOGGING

ELNet meter collects automatically important electrical data day by day, for approximately two years.

From the Main Menu scroll to “**Data Logging**“ and press “Enter”. The following screen appears.

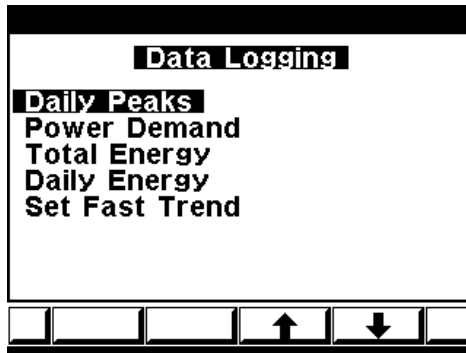

Figure 8.1. Data Logging

Daily peaks :

Scroll to “**Daily peaks**” and press “Enter”, then you will be able to get the following information:

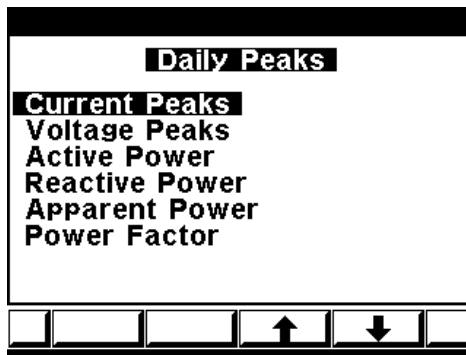
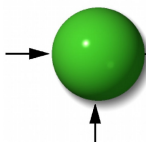

Figure 8.2. Daily Peaks



For each one of the above options you will have the ability to get for each phase the lowest-level value and the highest-level value as specified in the following screen:

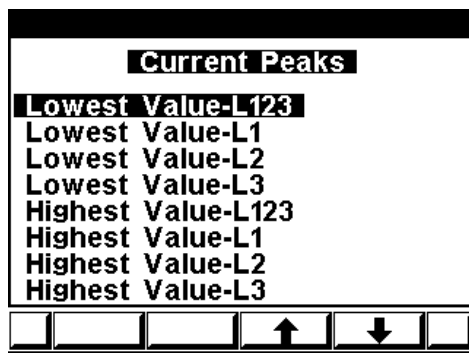

Figure 8.3. **Current Peaks**

Select one of the above options and press “Enter”, the following screen will appear:

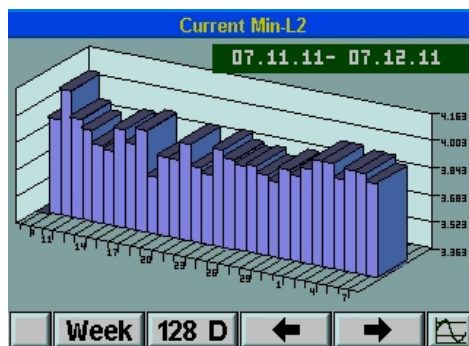
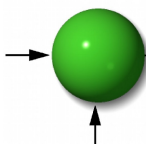

Figure 8.4. **Current Min. L1**

F1 / F2 – change the interval - time base between week/month/128 days

F3 / F4 – change the date, each press will increase/decrease the date by week/month/128 days.



Power Demand :

The operation method is very similar to the above paragraph “Daily peaks” and the information includes the maximum average for 15 minutes of the active power, reactive power and apparent power demand.

Total Energy :

The operation method is very similar to the above paragraph “Daily peaks” and the information includes the total energy values for active energy, reactive energy and apparent energy for each phase and total energy.

Daily Energy :

The operation method is very similar to the above paragraph “Daily peaks” and the information includes the daily energy consumption for active energy, reactive energy and apparent energy for each phase and total energy.

Set Fast Trend :

Selecting **Set Fast Trend** from the screen described in Figure 8.1. will enable you to set a trend report. The size of the trend report is 6939 samples of all the measurements (currents, voltages, power, power factor and more for all phases).

The user can set only the cycle time (sampling rate) and the range is from one second up to 3600 seconds (one hour)

Set Fast Trend				
Max Trend Records 6939				
Current Record 48				
Cycle Time-Seconds 0				
<input type="button" value=""/>	<input type="button" value="-"/>	<input type="button" value="+"/>	<input type="button" value="Stop"/>	<input type="button" value="Clear"/>

Figure 8.5. Set Fast Trend

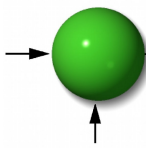

CHAPTER 9 — COMMUNICATION

9.1 Communication Connections

The *ELNet* Energy & Powermeter supports RS485 and Ethernet. The connection is provided on the Rear Panel, (see Figure 2.5 or 2.6) and is made by means of the connectors provided. The same information can be transmitted along both, but only one at a time. The user can choose the one that best suits his current situation and equipment.

The RJ45 sockets support a standard connection to any Ethernet network.

9.2 Communication Settings

To enable the *User* connecting the *ELNet* Energy & Powermeter to a PC **master** computer for successful communications, the Communication Setup parameters of both must match; i.e. the port of the PC **master** and the configuration settings of the Powermeter.

9.3 Address

Each Powermeter in a communication system must have its own unique address.

Since the *ELNet* Energy & Powermeter works on MODBUS, the available addresses are from '1' to '247'. BACnet communication is also available.

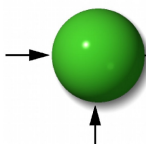

9.4 Baud Rate

The Baud Rate is the communication speed in Bits Per Second (BPS) that the ***ELNet*** Energy & Powermeter communicates with the PC **master**. The better the communication line Quality, the faster the communications may be.

If the communication line is routed through a “noisy” environment, it may be necessary to decrease the Baud Rate.

Available Baud Rates for the ***ELNet*** Energy & Powermeter:

600	bps
1200	bps
2400	bps
4800	bps (default)
9600	bps
19200	bps
38400	bps

9.5 Parity

The choices of parity are either NONE or EVEN.

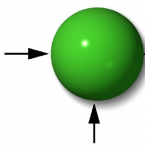

9.6 Communication Set Up

To set up Serial Communications

- 1 See Section 4.1 for instructions to arrive at the Technical Menu.
- 2 From Technical Menu scroll to **Communication Settings**
- 3 Click “Enter”, the **Communication Setup** screen appears.

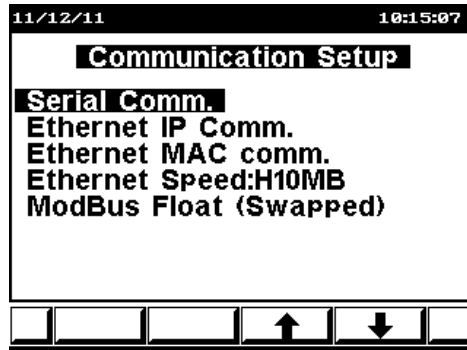

Figure 9.1. Communication Setup

- 4 From Communication Setup Menu scroll to **Serial Comm.**
- 5 Click “Enter”, the **Communications Settings** screen appears.

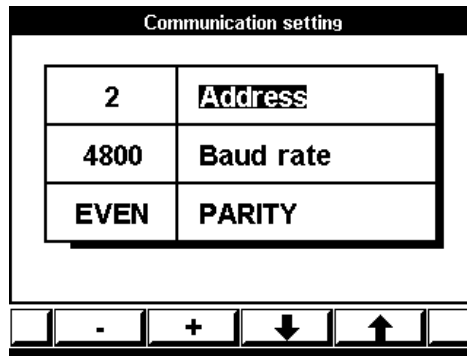
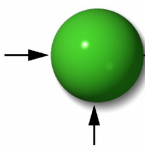

Figure 9.2. Communications Settings

- 6 Use Button “F1” or “F2” to change value in selected field.
- 7 Use Button “F3” or “F4” to select Address, Baud Rate, Parity.

NOTE!

When the selection is made it takes immediate affect with no further action required.

To set up Ethernet Communications

- 1 From the Communication Setup Menu scroll to **Ethernet Comm.**
- 2 Click “Enter”, the **Set IP Address** screen appears.

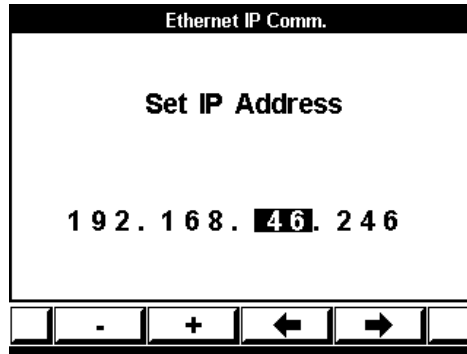
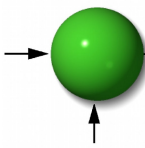
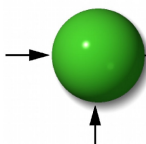

Figure 9.3. **Set IP Address**

- 3 Use Button “F1” or “F2” to change IP Address.
- 4 Use Button “F3” or “F4” to move the cursor.

- Click “Back” to return to Technical menu.
- Click “Back” to return to Main menu.



9.7 Communication with UniArt Software

CONTROL APPLICATIONS Ltd propriety software, “UniArt” is used to **Read** and **Write** Registers of the ***ELNet*** Energy & Powermeter. Each Item number in the Registers Table is a unique field containing information. The UniArt software manages each Item number as a parameter.

Refer to the UniArt manual how to set up parameters.

To read fields using UniArt

- 1 Find the reading required in the MODBUS Registers Table
- 2 Note the Item Number from the Registers Table
- 3 Go to the correct File number

Because File capacity in UniArt is limited to 128 parameters, the information contained in the ***ELNet*** fields is stored in several files.

File number is determined by the Item number

File # 0 contains	Item number	1 - 128
File # 1 contains	Item number	129 – 256
File # 2 contains	Item number	257 – 384
File # 3 contains	Item number	385 – 512

- 4 Go to the correct Point number within that file

Point number is determined by the formula:

$$\text{Item number} - [\text{FILE X } 128] = \text{Point Number}$$

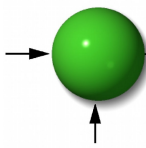

E.G. 1 If the user wishes to read Voltage Line 2 (Item No 2)
By applying the formula: $2 - [0 \times 128] = 2$
File = 0 and Point within that file = 2

E.G. 2 If the user wishes to read 30th Harmonics for Volts Line1
(Item No 330)
By applying the formula: $330 - [2 \times 128] = 74$
File = 2 and Point within that file = 74

E.G. 3 If the user wishes to read 7th Harmonic for Current Line 3
(Item No 467)
By applying the formula: $467 - [3 \times 128] = 83$
File = 3 and Point number within that file = 83

More Examples

E.G. No	Item No	Field Description	File	Point
1	2	Voltage Line 2	0	2
2	330	30 th Harmonics for Volts Line1	2	74
3	467	7 th Harmonic for Current Line 3	3	83
4	128		0	128
5	129		1	1
6	256		1	128
7	257		2	1
8	384	20 th Harmonics for Volts Line 3	2	128
9	385	21 st Harmonics for Volts Line3	3	1

Table 6.6 Examples how to calculate Point for UniArt

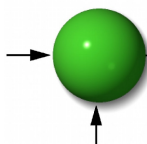

CHAPTER 10 — Specifications

Item	Description
Power requirements	110/230VAC,60/50 Hz, 30VA
Dimensions	(HxWxD) 144x144x100 mm
Shipping Weight	750 gr.
Measuring voltage limits	700 VAC
Measuring current limits	6 A
Operating Voltage limits	1000VAC
Operating Current limits	50A
Enclosure material	ABS Anti flame
Display	Graphic 160x128
Operating temperature	-20 - + 50 C
Storage temperature	-20 - + 80 C
Humidity	0- 90 RH%
Voltage input terminals	VL – E10 1708
Communication port	RS232(GR only)/ RS485/ TCP
Mounting	Front Panel Mounting

All technical specifications are subject to change without notice.

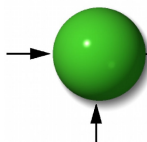

10.1 Measurement & Display

Elnet GR Measurement & Display (scaling factor 1)

Measurement Parameter	Display Range in direct connection (scaling factor 1)	Measuring in direct connection (scaling factor 1)	Display Range
Current	0.001 – 6A	0.001 – 6A	0.001 – 99999KA
Neutral Current (calculated)	0.001 – 6A	0.001 – 6A	0.001 – 99999KA
Voltage L-N	0.000 – 510 V	0.000 – 510 V	0.001 – 99999KV
Voltage L-L	0.000 – 510 V	0.000 – 510 V	0.001 – 99999KV
Frequency (Hz)	45.001-65.001 Hz	45.001-65.001 Hz	45.001-65.001 Hz
Active power total\phase			0.000W – 99999MW
Reactive power total\phase			0.000VAR - 99999MVAR
Apparent power total\phase			0.000VA - 99999MVA
Power Factor (cap.\ind.)	-1.000 ÷ 1.000	-1.000 ÷ 1.000	-1.000 ÷ 1.000
Active Energy total\phase			0.001WH – 99999999MWH
Reactive Energy total\phase			0.001VARH - 99999999MVARH
Apparent Energy total\phase			0.001VAH - 99999999MVAH
Harmonic THD V\I			0.000 – 100%
Partial Harmonic V\I			0.000 – 100%
Operating hour meter			99999- HH:MM:SS

Table 7.1 GR Measurement & Display

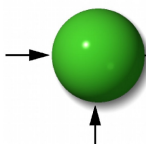

Elnet PQ Measurement & Display (scaling factor 1)

Measurement Parameter	Display Range in direct connection (scaling factor 1)	Measuring in direct connection (scaling factor 1)	Display Range
Current	0.001 – 6A	0.001 – 6A	0.001 – 99999KA
Neutral Current	0.001 – 6A	0.001 – 6A	0.001 – 99999KA
Voltage L-N	0.000 – 510 V	0.000 – 510 V	0.001 – 99999KV
Voltage L-L	0.000 – 510 V	0.000 – 510 V	0.001 – 99999KV
Frequency (Hz)	45.001-65.001 Hz	45.001-65.001 Hz	45.001-65.001 Hz
Active power total\phase			0.000W – 99999MW
Reactive power total\phase			0.000VAR - 99999MVAR
Apparent power total\phase			0.000VA - 99999MVA
Power Factor (cap.\ind.)	-1.000 ÷ 1.000	-1.000 ÷ 1.000	-1.000 ÷ 1.000
Active Energy total\phase			0.001WH – 99999999MWH
Reactive Energy total\phase			0.001VARH - 99999999MVARH
Apparent Energy total\phase			0.001VAH - 99999999MVAH
Harmonic THD V\I			0.000 – 100%
Partial Harmonic V\I			0.000 – 100%
Operating hour meter			99999- HH:MM:SS

Table 7.2 PQ Measurement & Display

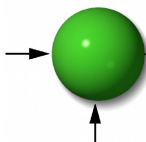

Appendix A — Installation & Configuration Check List

INSTALLATION CHECK LIST

Description	Date	Signature
Check contents of packaging		
Remove from packaging		
Prepare hole		
Mount Meter		
Connect Meter power supply		
Connect 3 Current Transformers		
Connect 3 Voltage lines		
Connect Neutral line		
Set Current Transformer Ratio		
Connect Communication lines		
Check Phase Order Connections		
Set Time and Date		

Appendix A Table - Installation & Configuration Check List