



**ESM-4400 48 x 48 1/16 DIN  
Universal Input Process Indicator with Smart  
Output Module System**

- 4 digits Process (PV) Display
- Universal Process Input (TC, RTD, mV---, V---, mA---)
- Dual or Multi Point Calibration for ---Voltage / Current Input
- Smart Output Module System
- Programmable Alarm Functions
- Retransmission of Process Value or Process Control by Using 0/4...20 mA--- Current Output Module
- Hardware Configuration With Output Modules
- RS-232 (standard) or RS-485 (optional) Serial Communication With Modbus RTU Protocol

## ABOUT INSTRUCTION MANUAL

Instruction manual of ESM-4400 Process Indicator consists of two main sections. Explanation of these sections are below. Also, there are other sections which include order information and technical specifications of the device. All titles and page numbers in instruction manual are in "CONTENTS" section. User can reach to any title with section number.

### Installation:

In this section, physical dimensions of the device, panel mounting, electrical wiring, module mounting in the device, physical and electrical installation of the device to the system are explained.

### Operation and Parameters:

In this section, user interface of the device, how to access to the parameters, description of parameters are explained.

Also in these sections, there are warnings to prevent serious injury while doing the physical and electrical mounting or using the device.

Explanation of the symbols which are used in these sections are given below.



This symbol is used for safety warnings. User must pay attention to these warnings.



This symbol is used to determine the dangerous situations as a result of an electric shock. User must pay attention to these warnings definitely.



This symbol is used to determine the important notes about functions and usage of the device.



In parameters section, for making relevant parameters to be active, determined module must be installed to Module-1 or Module-2 socket.

## CONTENTS

<b>1.PREFACE</b> .....	Page	6
1.1 GENERAL SPECIFICATIONS		
1.2 ORDERING INFORMATION		
1.3 WARRANTY		
1.4 MAINTENANCE		
<b>2.INSTALLATION</b> .....	Page	9
2.1 GENERAL DESCRIPTION		
2.2 DIMENSIONS		
2.3 PANEL CUT-OUT		
2.4 ENVIRONMENTAL RATINGS		
2.5 PANEL MOUNTING		
2.6 INSTALLATION FIXING CLAMP		
2.7 REMOVING FROM THE PANEL		
<b>3.ELECTRICAL WIRINGS</b> .....	Page	14
3.1 TERMINAL LAYOUT AND CONNECTION INSTRUCTION		
3.2 ELECTRICAL WIRING DIAGRAM		
3.3 SUPPLY VOLTAGE INPUT CONNECTION OF THE DEVICE		
3.4 PROCESS INPUT CONNECTION		
3.4.1 TC (THERMOCOUPLE) CONNECTION		
3.4.2 RTD CONNECTION		
3.4.3 PROCESS INPUT CONNECTION OF SERIAL TRANSMITTERS WITH CURRENT OUTPUT (LOOP POWERED)		
3.4.4 PROCESS INPUT CONNECTION OF 3-WIRE TRANSMITTERS WITH CURRENT OUTPUT		
3.4.5 CONNECTION OF TRANSMITTERS WITH VOLTAGE OUTPUT TO PROCESS INPUT		
3.5 RELAY OUTPUT CONNECTION		
3.6 GALVANIC ISOLATION TEST VALUES OF ESM-4400 PROCESS INDICATOR AND OUTPUT MODULES		
<b>4.DEFINITIONS AND SPECIFICATIONS OF MODULES</b> .....	Page	21
4.1 OUTPUT MODULES		
4.1.1 EMO-400 RELAY OUTPUT MODULE		
4.1.2 EMO-410 SSR DRIVER OUTPUT MODULE		
4.1.3 EMO-420 DIGITAL (TRANSISTOR) OUTPUT MODULE		
4.1.4 EMO-430 0/4 ...20mA== CURRENT OUTPUT MODULE		
4.2 INSTALLING AND PULLING OUT OUTPUT MODULES		
4.3 TO STICK OUTPUT MODULES' LABELS TO THE DEVICE		
<b>5.CONNECTION TERMINALS OF OUTPUT MODULES AND CONNECTION WIRINGS</b> .....	Page	27
5.1 CONNECTION WIRINGS FOR OUTPUT MODULES		
5.1.1 EMO-400 RELAY OUTPUT MODULE CONNECTION		
5.1.2 EMO-410 SSR DRIVER OUTPUT MODULE CONNECTION		
5.1.3 EMO-420 DIGITAL (TRANSISTOR) OUTPUT MODULE CONNECTION		
5.1.4 EMO-430 0/4 ...20mA== CURRENT OUTPUT MODULE CONNECTION		
5.1.5 TO GET 0...10V== WITH EMO-430 0/4 ...20mA== CURRENT OUTPUT MODULE		
<b>6.CONNECTIONS FOR RS-232 / RS-485 SERIAL COMMUNICATION</b> .....	Page	29
6.1 CABLE CONNECTION BETWEEN RS-232 TERMINAL OF THE DEVICE AND PC		
6.2 CONNECTION FOR RS-485 SERIAL COMMUNICATION		
6.3 INSTALLING RS-232 / RS-485 SERIAL COMMUNICATION MODULES TO THE DEVICE		
<b>7.DEFINITION OF FRONT PANEL AND ACCESSING TO THE PARAMETERS</b> .....	Page	32
7.1 DEFINITION OF FRONT PANEL		
7.2 OBSERVATION OF OPTIONAL MODULES AND SOFTWARE REVISION ON THE DISPLAYS		
7.3 ADJUSTMENT OF ALARM SET VALUES		
7.4 ACCESSING TO THE TECHNICIAN MENU		
7.5 CHANGING AND SAVING PARAMETERS		

<b>8.PARAMETERS</b> .....	Page	49
8.1 ALARM SET PARAMETERS		
8.2 TECHNICIAN PARAMETERS		
8.2.1 PROCESS INPUT TYPE AND RELEVANT PARAMETERS WITH PROCESS INPUT		
8.2.2 MODULE-1 CONFIGURATION PARAMETERS		
8.2.3 MODULE-2 CONFIGURATION PARAMETERS		
8.2.4 OUTPUT-3 CONFIGURATION PARAMETERS		
8.2.5 GENERAL PARAMETERS		
8.2.6 PARAMETERS FOR CONFIGURATION OF SERIAL COMMUNICATION		
8.2.7 TECHNICIAN PASSWORD		
<b>9.FAILURE MESSAGES IN ESM-4400 PROCESS INDICATORS</b> .....	Page	63
<b>10.SPECIFICATIONS</b> .....	Page	65

## **EU DECLARATION OF CONFORMITY**

**Manufacturer Company Name** : Emko Elektronik A.S.

**Manufacturer Company Address:** DOSAB, Karanfil Sokak, No:6, 16369 Bursa, Turkiye

**The manufacturer hereby declares that the product conforms to the following standards and conditions.**

**Product Name** : Process Indicator

**Model Number** : ESM-4400

**Type Number** : ESM-4400

**Product Category** : Electrical equipment for measurement, control and laboratory use

**Conforms to the following directives :**

**73 / 23 / EEC The Low Voltage Directive as amended by 93 / 68 / EEC**

**89 / 336 / EEC The Electromagnetic Compatibility Directive**

**Has been designed and manufactured according to the following specifications**

**EN 61000-6-4:2001 EMC Generic Emission Standard for the Industrial Environment**

**EN 61000-6-2:2001 EMC Generic Immunity Standard for the Industrial Environment**

**EN 61010-1:2001 Safety Requirements for electrical equipment for measurement, control and laboratory use**

## 1.Preface

ESM series process indicators are designed for measuring temperature and any process value. They can be used in many applications with their universal process input, alarm functions and serial communication unit.

Some application fields which they are used are below:

### Application Fields

Glass  
Plastic  
Petro-Chemistry  
Textile  
Automotive  
Machine production industries

## 1.1 General Specifications

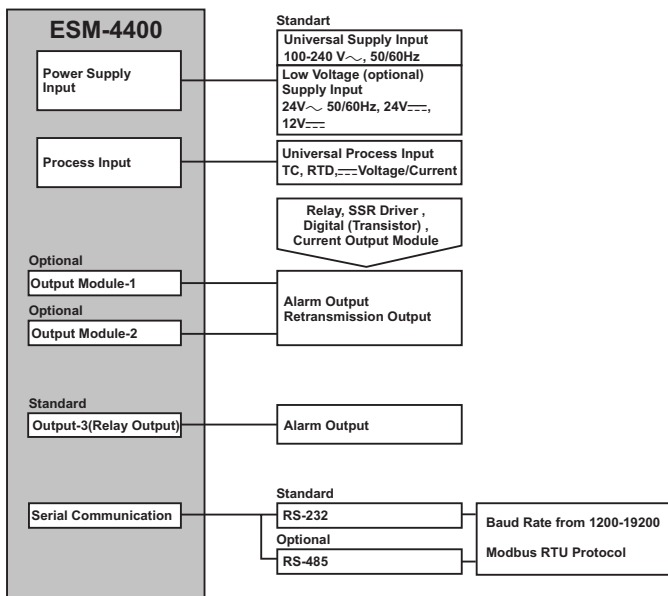

## 1.2 Ordering Information

<b>ESM-4400</b> (4E-48 1/16 DIN)	A	B	C	D	E	F	G	H	I	U	V	W	Z
					1	/	/	/	/	/			

<b>A Supply Voltage</b>
1 100-240V $\sim$ (-15%+10%) 50/60Hz
2 24 V $\sim$ (-15%+10%) 50/60Hz 24V $\sim$ (-15%+10%)
6 12 V $\sim$ (-15%+10%)
9 Customer (Maximum 240V $\sim$ (-15%+10%)50/60Hz)

<b>BC Input Type</b>	<b>Scale</b>
20 Configurable(Table-1)	Table-1

<b>D Serial Communication</b>	<b>Product Code</b>
0 None	-
1 RS-232	EMC-400
2 RS-485	EMC-410

<b>E Output-1</b>
1 Relay Output

<b>FG Module-1</b>	<b>Product Code</b>
00 None	-
01 Relay Output Module	EMO-400
02 SSR Driver Output Module	EMO-410
03 Digital (Transistor) Output Module	EMO-420
04 Current Output Module ( 0/4 ...20 mA $\sim$ )	EMO-430

<b>HI Module-2</b>	<b>Product Code</b>
00 None	-
01 Relay Output Module	EMO-400
02 SSR Driver Output Module	EMO-410
03 Digital (Transistor) Output Module	EMO-420
04 Current Output Module ( 0/4 ...20 mA $\sim$ )	EMO-430

Table-1

BC Input Type(TC)	Scale(°C)	Scale(°F)
21 L ,Fe Const DIN43710	-100°C,850°C	-148°F,1562°F
22 L ,Fe Const DIN43710	-100.0°C,850.0°C	-148.0°F,999.9°F
23 J ,Fe CuNi IEC584.1(ITS90)	-200°C,900°C	-328°F,1652°F
24 J ,Fe CuNi IEC584.1(ITS90)	-199.9°C,900.0°C	-199.9°F,999.9°F
25 K ,NiCr Ni IEC584.1(ITS90)	-200°C,1300°C	-328°F,2372°F
26 K ,NiCr Ni IEC584.1(ITS90)	-199.9°C,999.9°C	-199.9°F,999.9°F
27 R ,Pt13%Rh Pt IEC584.1(ITS90)	0°C,1700°C	32°F,3092°F
28 R ,Pt13%Rh Pt IEC584.1(ITS90)	0.0°C,999.9°C	32.0°F,999.9°F
27 S ,Pt10%Rh Pt IEC584.1(ITS90)	0°C,1700°C	32°F,3092°F
28 S ,Pt10%Rh Pt IEC584.1(ITS90)	0.0°C,999.9°C	32.0°F,999.9°F
29 T ,Cu CuNi IEC584.1(ITS90)	-200°C,400°C	-328°F,752°F
30 T ,Cu CuNi IEC584.1(ITS90)	-199.9°C,400.0°C	-199.9°F,752.0°F
31 B ,Pt30%Rh Pt6%Rh IEC584.1(ITS90)	44°C,1800°C	111°F,3272°F
32 B ,Pt30%Rh Pt6%Rh IEC584.1(ITS90)	44.0°C,999.9°C	111.0°F,999.9°F
33 E ,NiCr CuNi IEC584.1(ITS90)	-150°C,700°C	-238°F,1292°F
34 E ,NiCr CuNi IEC584.1(ITS90)	-150.0°C,700.0°C	-199.9°F,999.9°F
35 N ,Niocrsil Nisil IEC584.1(ITS90)	-200°C,1300°C	-328°F,2372°F
36 N ,Niocrsil Nisil IEC584.1(ITS90)	-199.9°C,999.9°C	-199.9°F,999.9°F
37 C , (ITS90)	0°C,2300°C	32°F,3261°F
38 C , (ITS90)	0.0°C,999.9°C	32.0°F,999.9°F

BC Input Type(RTD)	Scale(°C)	Scale(°F)
39 PT 100 ,IEC751(ITS90)	-200°C,650°C	-328°F,1202°F
40 PT 100 ,IEC751(ITS90)	-199.9°C,650.0°C	-199.9°F,999.9°F

BC Input Type (--- Voltage and Current)	Scale
41 0...50 mV $\sim$	-1999 9999
42 0...5 V $\sim$	-1999 9999
43 0...10 V $\sim$	-1999 9999
44 0...20 mA $\sim$	-1999 9999
45 4...20 mA $\sim$	-1999 9999

All order information of ESM-4400 are given on the table at left. User may form appropriate device configuration from information and codes that at the table and convert it to the ordering codes.

Firstly, supply voltage then output modules and other specifications must be determined. Please fill the order code blanks according to your needs.

Please contact us, if your needs are out of the standards.



EMO-410, EMO-420 and EMC-410 modules can not be used in 12V $\sim$  type.



$\sim$  Symbol means Vac,

$\sim$  Symbol means Vdc

$\sim$  Symbol means Vac and Vdc

### **1.3 Warranty**

EMKO Elektronik warrants that the equipment delivered is free from defects in material and workmanship. This warranty is provided for a period of two years. The warranty period starts from the delivery date. This warranty is in force if duty and responsibilities which are determined in warranty document and instruction manual performs by the customer completely.

### **1.4 Maintenance**

Repairs should only be performed by trained and specialized personnel. Cut power to the device before accessing internal parts.

Do not clean the case with hydrocarbon-based solvents (Petrol, Trichlorethylene etc.). Use of these solvents can reduce the mechanical reliability of the device. Use a cloth dampened in ethyl alcohol or water to clean the external plastic case.



## 2. Installation



Before beginning installation of this product, please read the instruction manual and warnings below carefully.

In package ,

- One piece unit
- One piece mounting clamp
- One piece instruction manual

A visual inspection of this product for possible damage occurred during shipment is recommended before installation. It is your responsibility to ensure that qualified mechanical and electrical technicians install this product.

If there is danger of serious accident resulting from a failure or defect in this unit, power off the system and separate the electrical connection of the device from the system.

The unit is normally supplied without a power switch or a fuse. Use power switch and fuse as required.

Be sure to use the rated power supply voltage to protect the unit against damage and to prevent failure.

Keep the power off until all of the wiring is completed so that electric shock and trouble with the unit can be prevented.

Never attempt to disassemble, modify or repair this unit. Tampering with the unit may result in malfunction, electric shock or fire.

Do not use the unit in combustible or explosive gaseous atmospheres.

During the equipment is putted in hole on the metal panel while mechanical installation some metal burrs can cause injury on hands, you must be careful.

Montage of the product on a system must be done with it's mounting clamp. Do not do the montage of the device with inappropriate mounting clamp. Be sure that device will not fall while doing the montage.

It is your responsibility if this equipment is used in a manner not specified in this instruction manual.

## 2.1 General Description

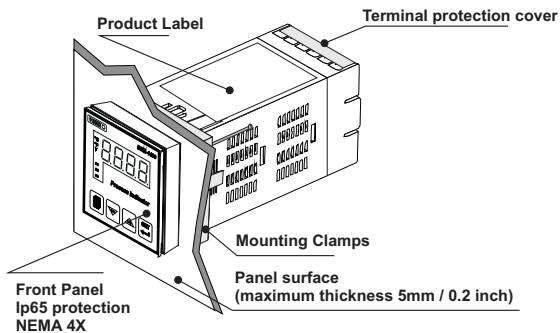

## 2.2 Dimensions

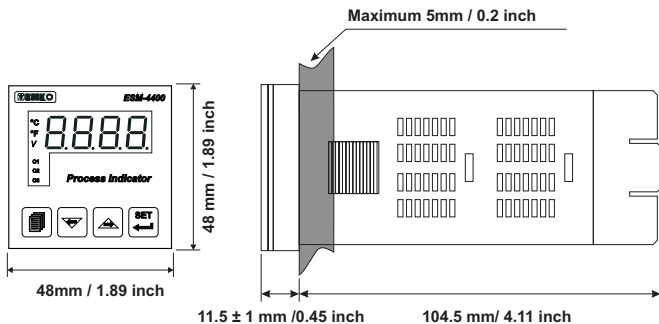

## 2.3 Panel Cut-Out

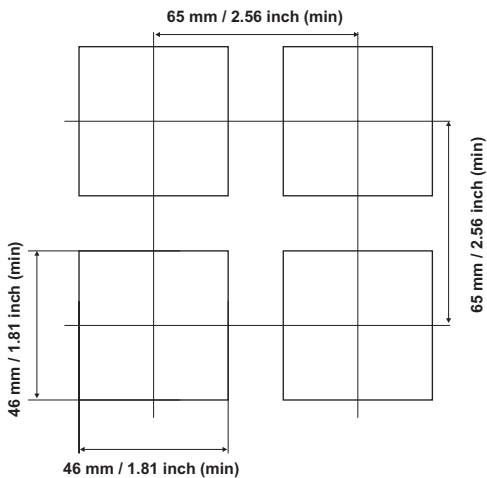

## 2.4 Environmental Ratings

### Operating Conditions



**Operating Temperature** : 0 to 50 °C



**Max. Operating Humidity** : 90% Rh (non-condensing)



**Altitude** : Up to 2000m.



#### Forbidden Conditions:

Corrosive atmosphere

Explosive atmosphere

Home applications (The unit is only for industrial applications)

## 2.5 Panel Mounting

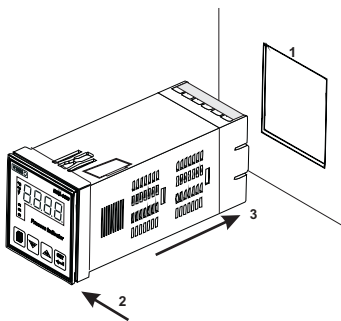

1-Before mounting the device in your panel, make sure that the cut-out is of the right size.

2-Check front panel gasket position

3-Insert the device through the cut-out. If the mounting clamps are on the unit, put out them before inserting the unit to the panel.



During installation into a metal panel, care should be taken to avoid injury from metal burrs which might be present. The equipment can loosen from vibration and become dislodged if installation parts are not properly tightened. These precautions for the safety of the person who does the panel mounting.

## 2.6 Installation Fixing Clamp

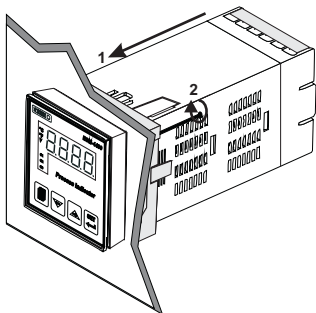

The unit is designed for panel mounting.

1-Insert the unit in the panel cut-out from the front side.

2-Insert the mounting clamp from the rear side of the unit and screw up the fixing screws until the unit completely immobile within the panel



Montage of the unit to a system must be done with it's own fixing clamps. Do not do the montage of the device with inappropriate fixing clamps. Be sure that device will not fall while doing the montage.

## 2.7 Removing from the Panel



Before starting to remove the unit from panel, power off the unit and the related system.

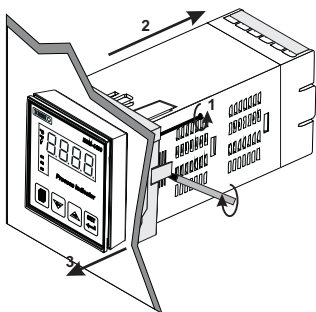

1-Loosen the screws.

2-Lift the locking tabs located on both the right and left hand sides and pull the fixing clamp from the device while holding the unit in place.

3-Pull the unit through the front side of the panel

### 3. Electrical Wirings



You must ensure that the device is correctly configured for your application. Incorrect configuration could result in damage to the process being controlled, and/or personal injury. It is your responsibility, as the installer, to ensure that the configuration is correct.

Parameters of the device has factory default values. These parameters must be set according to the system's needs.



Only qualified personnel and technicians should work on this equipment. This equipment contains internal circuits with voltage dangerous to human life. There is severe danger for human life in the case of unauthorized intervention.



Be sure to use the rated power supply voltage to protect the unit against damage and to prevent failure.



Keep the power off until all of the wiring is completed so that electric shock and trouble with the unit can be prevented.

#### 3.1 Terminal Layout and Connection Instructions

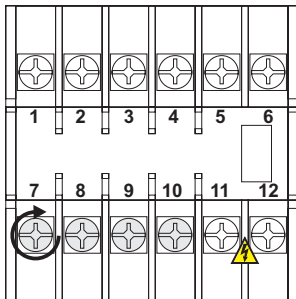

0.5 Nm

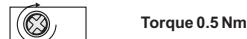
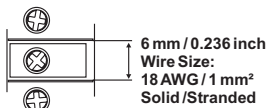

### 3.2 Electrical Wiring Diagram



Electrical wiring of the device must be the same as 'Electrical Wiring Diagram' below to prevent damage to the process being controlled and personnel injury.

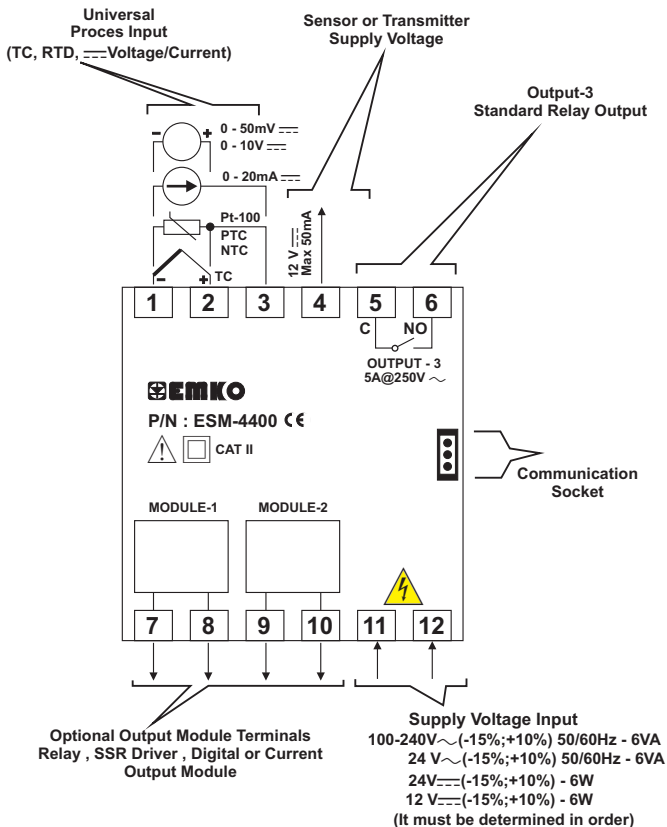

Process input is in CAT II class.

### 3.3 Supply Voltage Input Connection of the Device

Connection of Universal Supply Voltage Input

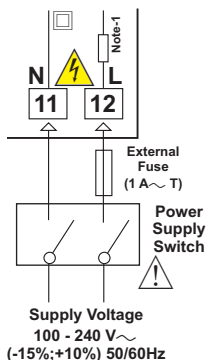

Connection of Low Voltage 24 V $\sim$  Supply Voltage Input

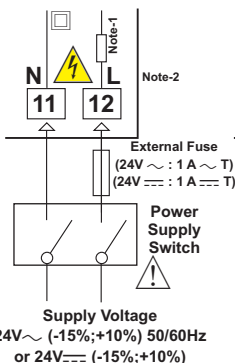

Connection of Low Voltage 12V $\sim\sim$  Supply Voltage Input

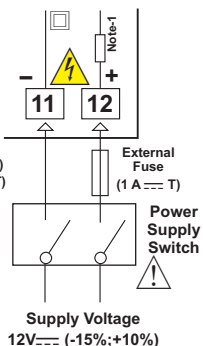

**Note-1:** There is internal 33R $\Omega$  fusible flameproof resistor in 100-240 V $\sim$  50/60Hz

There is internal 4R7 $\Omega$  fusible flameproof resistor in 24V $\sim$  50/60Hz, 24V $\sim\sim$  and 12V $\sim\sim$

**Note-2:** "L" is (+), "N" is (-) for 24V $\sim\sim$  supply voltage



Supply voltage range must be determined in order. While installing the unit, supply voltage range must be controlled and appropriate supply voltage must be applied to the unit. Controlling prevents damages in unit and system and possible accidents as a result of incorrect supply voltage.



There is no power switch or fuse on the device. So a power switch and a fuse must be added to the supply voltage input. Power switch and fuse must be put to a place where user can reach easily.



Power switch must be two poled for separating phase and neutral. On/Off condition of power switch is very important in electrical connection. On/Off condition of power switch must be signed for preventing the wrong connection.



External fuse must be on phase connection in  $\sim$  supply input.  
External fuse must be on (+) line connection in  $\sim\sim$  supply input.



### 3.4 Process Input Connection

#### 3.4.1 TC (Thermocouple) Connection

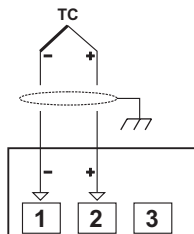

Connect the wires with the polarity as shown in the figure left.



Always use compensation wire corresponding to the thermocouple used. If present, the shield must be connected to a proper ground.



Input resistance is greater than 10M  $\Omega$ .

#### 3.4.2 RTD Connection

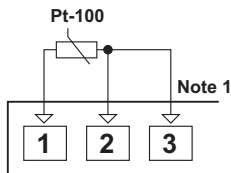

3-wire Pt-100 connection  
(with line compensation)  
(Max. Line impedance is 10  $\Omega$ )

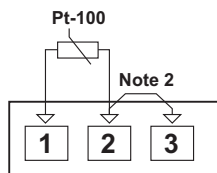

2-wire Pt-100 connection  
(without line compensation)

**Note 1 :** In 3-wire system, use always cables of the same diameter (min 1mm<sup>2</sup>) Always use wires of the same gauge and type whether a 2-wire or 3-wire system.

**Note 2 :** Install a jumper between terminals 2 and 3 when using a 2-wire RTD.

**Note 3 :** If the distance is longer than 10 meters, use 3-wire system



Input resistance is greater than 10M  $\Omega$ .

### 3.4.3 Process Input Connection of Serial Transmitters with Current Output (Loop Powered)

Transmitter connection by using supply voltage on the device

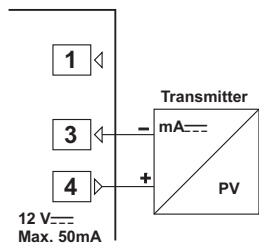

Transmitter connection by using external supply voltage source.

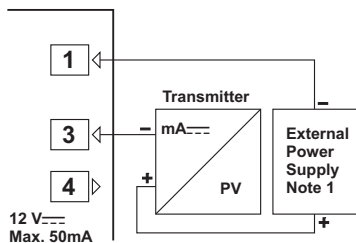

**Note 1 :** External power supply must be selected according to supply voltage range and required current for transmitter.



Input resistance is  $2R7 \Omega$ .

### 3.4.4 Process Input Connection of 3-Wire Transmitters with Current Output

Transmitter connection by using supply voltage on the device

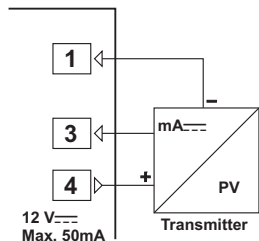

Transmitter connection by using external supply voltage source.

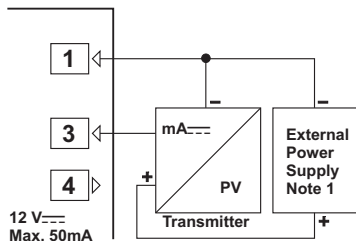

**Note 1 :** External power supply must be selected according to supply voltage range and required current for transmitter.



Input resistance is  $2R7 \Omega$ .

### 3.4.5 Connection of Transmitters with Voltage Output to Process Input

Transmitter connection by using supply voltage on the device

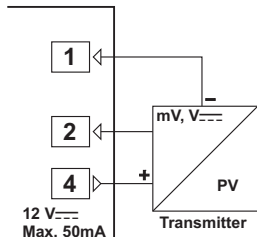

Transmitter connection by using external supply voltage source.

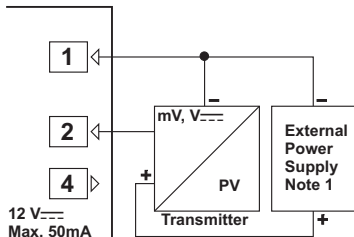

**Note 1 :** External power supply must be selected according to supply voltage range and required current for transmitter.



Input resistance is greater than  $10\text{M}\Omega$  for  $0\dots50\text{mV}\text{---}$   
 Input resistance is  $43\text{K}\Omega$  for  $0\dots10\text{V}\text{---}$

### 3.5 Relay Output Connection

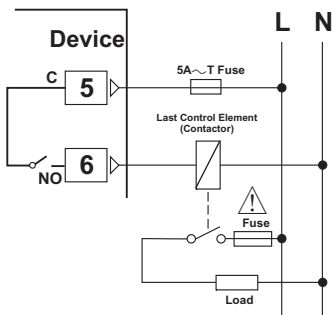

Fuses must be selected according to the application.

### 3.6 Galvanic Isolation Test Values of ESM-4400 Process Indicator and Output Modules

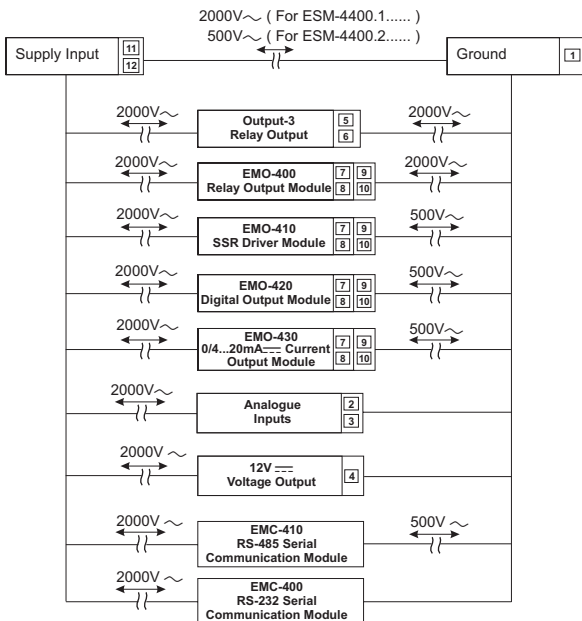

## 4. Definitions and Specifications of Modules

ESM-4400 Process Indicator is a modular product which is designed to operate with additional analogue and digital output units which user may need.

Two output modules can be plugged in the device by the user. User may configure the product for different applications according to the system requirements with the output modules which are described in this section.

### 4.1 Output Modules

#### Dimensions of Output Modules

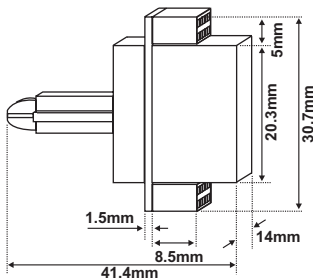

#### 4.1.1 EMO-400 Relay Output Module

EMO-400 Relay output module can be plugged in Module-1 or Module-2 socket to use functions which are defined for relay output.

##### Specifications of EMO-400 Relay Output Module

<b>Output</b>	: 3A @ 250V~, Single Open Contact
<b>Dimensions</b>	: 14x30.7x41.4mm
<b>Electrical Life</b>	: 100.000 Operation (Full Load)

##### Applications of EMO-400 Relay Output Module

It can be used with heating or cooling functions as process control output, as alarm output by programmable different alarm functions, as logic output to transfer some datas on the device to the system. These alternatives are explained in parameters section as logic output function.



Detailed information about functions of EMO-400 Relay Output Module are given in parameters section. For using these functions EMO-400 Relay Output Module must be installed to Module-1 or Module-2 socket.

#### 4.1.2 EMO-410 SSR Driver Output Module

EMO-410 SSR Driver Output Module can be plugged in Module-1 or Module-2 socket to use functions which are defined for SSR driver output.

##### Specifications of EMO-410 SSR Driver Module

**Output** : Maximum 20 mA, 15-18V $\pm$ 10%, isolated

**Dimensions** : 14x30.7x41.4mm

##### Applications of EMO-410 SSR Driver Output Module

It can be used with heating or cooling functions as process control output, as alarm output by programmable different alarm functions, as logic output to transfer some datas on the device to the system.

**Note 1** : If short output period is needed in a system, using SSR Driver output module is recommended. ( Relay must not be used for short output periods because of limited life of their relay contact (open/close events))



Detailed information about functions of EMO-410 SSR Driver Output Module are given in parameters section. For using these functions EMO-410 SSR Driver Output Module must be installed to Module-1 or Module-2 socket.



This module can not be used in 12V type.

#### 4.1.3 EMO-420 Digital (Transistor) Output Module

EMO-420 Digital (Transistor) Output Module can be plugged in Module-1 or Module-2 socket to use functions which are defined for digital output.

##### Specifications of EMO-420 Digital (Transistor) Output Module

**Output** : Maximum 40 mA, 15-18V $\pm$ 10%, isolated

**Dimensions** : 14x30.7x41.4mm

##### Applications of EMO-420 Digital (Transistor) Output Module

It can be used with heating or cooling functions as process control output, as alarm output by programmable different alarm functions, as logic output to transfer some datas on the device to the system. These alternatives are explained in parameters section as logic output function.



Detailed information about functions of EMO-420 Digital (Transistor) Output Module are given in parameters section. For using these functions EMO-420 Digital (Transistor) Output Module must be installed to Module-1 or Module-2 socket.



This module can not be used in 12V type.

#### 4.1.4 EMO-430 0 / 4 ...20mA $\overline{\text{---}}$ Current Output Module

EMO-430 0/4...20mA $\overline{\text{---}}$  Current Output Module can be plugged in Module-1 or Module-2 socket to use functions which are defined for current or voltage output. (It is defined as Analogue Output Module in some sections)

##### Specifications of EMO-430 0/4...20mA $\overline{\text{---}}$ Current Output Module

**Output** : 0/4...20mA $\overline{\text{---}}$  current output

**Accuracy** : 1%

**Note** : To get 0...10V $\overline{\text{---}}$  , 500 $\Omega$  resistor with 0.05% tolerance must be connected in parallel as a shunt resistor to module output (Please refer to Section 5.1.5 for detailed information)

**Maximum load impedance** : 600  $\Omega$

**Dimensions** : 14x30.7x41.4mm

##### Applications of EMO-430 0/4...20mA $\overline{\text{---}}$ Current Output Module

It can be used in heating or cooling functions as process control output.

Process value, difference between process and set value or set value can be retransmitted to the system as 0...20mA $\overline{\text{---}}$  or 4...20mA $\overline{\text{---}}$  output. Retransmission is explained in parameters section.



Detailed information about functions of EMO-430 Current Output Module are given in parameters section. For using these functions EMO-430 0/4...20mA $\overline{\text{---}}$  current Output Module must be installed to Module-1 or Module-2 socket.

## 4.2 Installing and Pulling Out Input/Output Modules



First, detach all cable connections from the device and uninstall it from the panel.



Suppress to the lock pins where top and bottom of the device

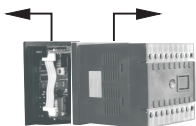

Pull the cover case with your other hand from front panel to rear side.

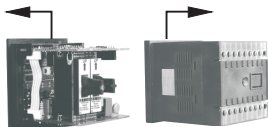

Pull out the cover case from the device



Slide input/output modules into socket.

Pull out the module from it's socket, instead of this module install the new one or other module user wants to use.

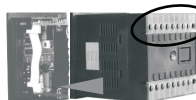

Replace the cover case by taking care of the terminal numbers should be at right position.



After adding or changing modules to the unit, these changes must be taken into consideration while mounting of the unit to the system. If mounting is incorrect, it can cause accidents to harm system, operator or person who does the mounting. Responsibility of these kind of harmful events belongs to the user.



### 4.3 To Stick Output Modules' Labels to the Device

Every module which is plugged in Module-1 or Module-2 socket has labels' for showing the relation between connection terminal and the device. These labels are attached to empty boxes which are separated for Module-1 and Module-2 on the device. Labels for all modules and attachment places are shown below.

Label which describes terminal connection of module that is plugged in Module-2 socket is attached to this area.

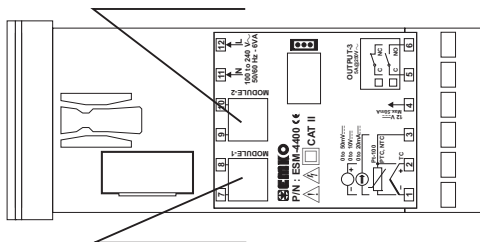

Label which describes terminal connection of module that is plugged in Module-1 socket is attached to this area.

#### LABELS FOR OUTPUT MODULES



Label for EMO-400 Relay Output Module



Label for EMO-410 SSR Driver Output Module



Label for EMO-420 Digital Output Module



Label for EMO-430 0/4...20mA Current Output Module

**Example :** If user installs EMO-400 Relay Output Module to Module-1 socket, EMO-430 0/4...20mA $\sim$  Current Output Module to Module-2 socket and attach the appropriate labels on the device view will be like below :

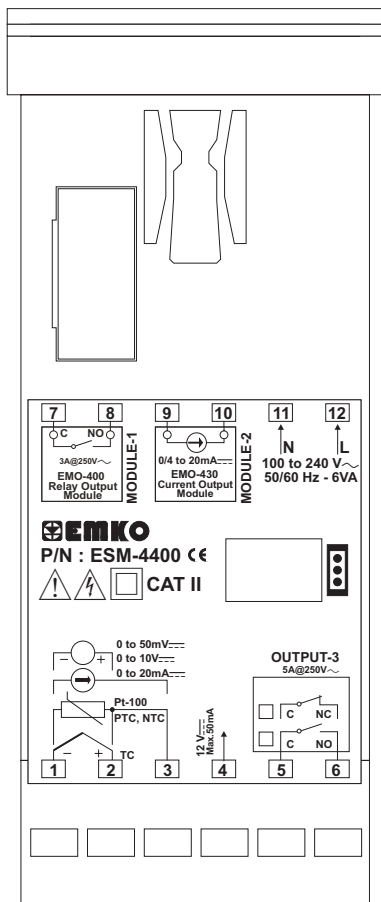

## 5. Connection Terminals of Output Modules and Connection Wirings

### Module-1 / Module-2 Optional Output Modules

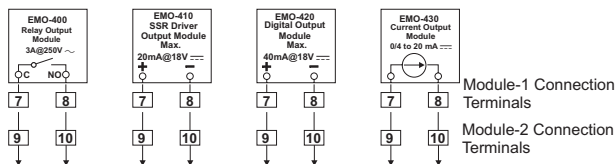

### 5.1 Connection Wirings for Output Modules

#### 5.1.1 EMO-400 Relay Output Module Connection

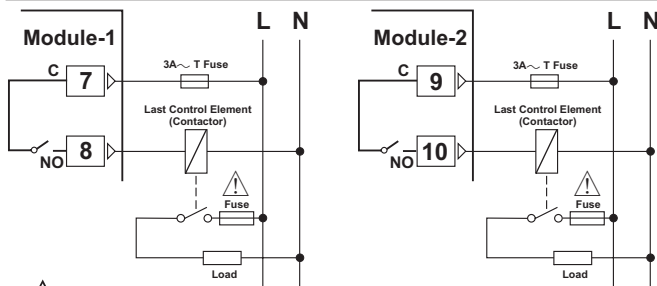

Fuses must be selected according to the applications.

#### 5.1.2 EMO-410 SSR Driver Output Module Connection

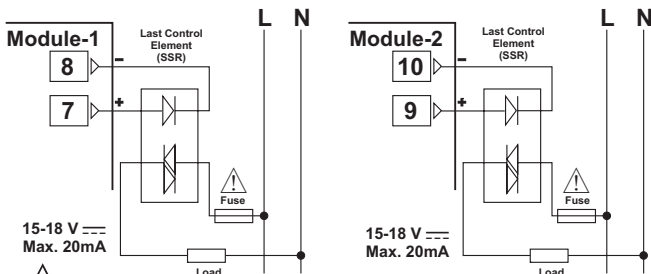

Fuses must be selected according to the applications.

### 5.1.3 EMO-420 Digital (Transistor) Output Module Connection

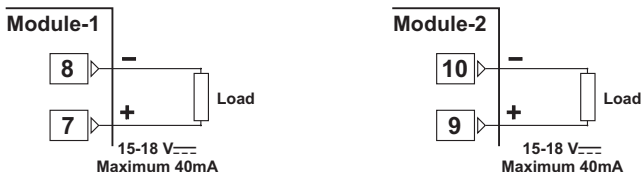

### 5.1.4 EMO-430 0/4... 20 mA<sub>DC</sub> Current Output Module Connection

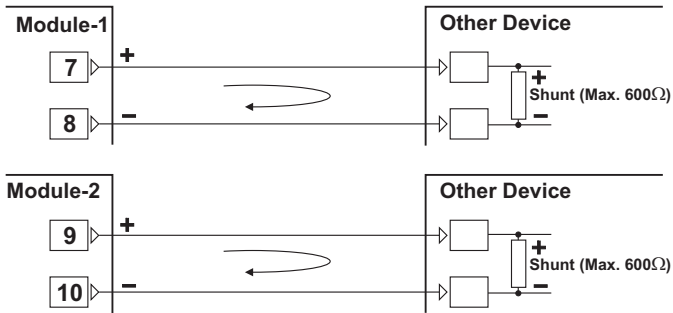

### 5.1.5 To Get 0...10V<sub>DC</sub> with EMO-430 0/4...20 mA<sub>DC</sub> Current Output Module

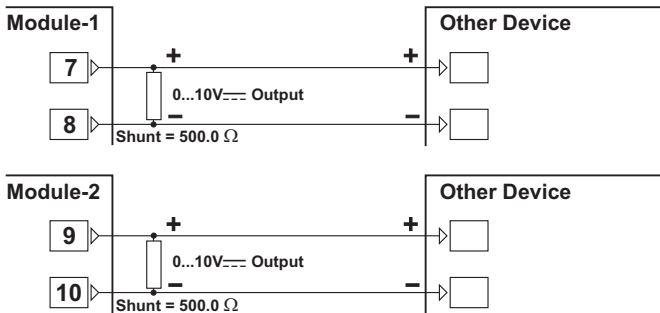

## 6. Connections for RS-232 / RS-485 Serial Communication

### RS-232 Terminal Definitions

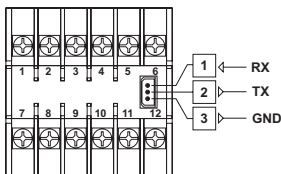

### RS-485 Terminal Definitions

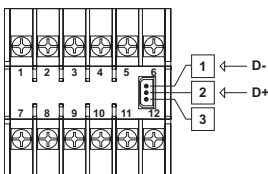

## 6.1 Cable Connection Between RS-232 Terminal of the Device and PC

### ESM-4400

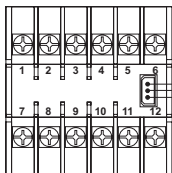

Cable Length must be max. 12 meters for 9600 baud rate

### PC (Personal Computer) 9 Pin DCON connection

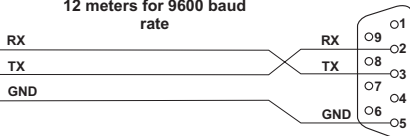

### ESM-4400

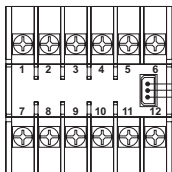

Cable Length must be max. 12 meters for 9600 baud rate

### PC (Personal Computer) 25 Pin DCON connection

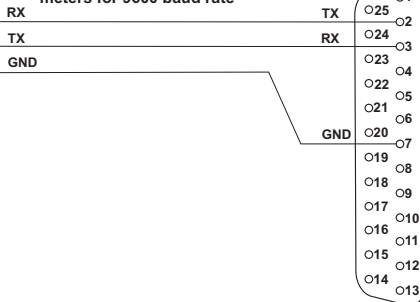

## 6.2 Connection for RS-485 Serial Communication

PC(Personal Computer)

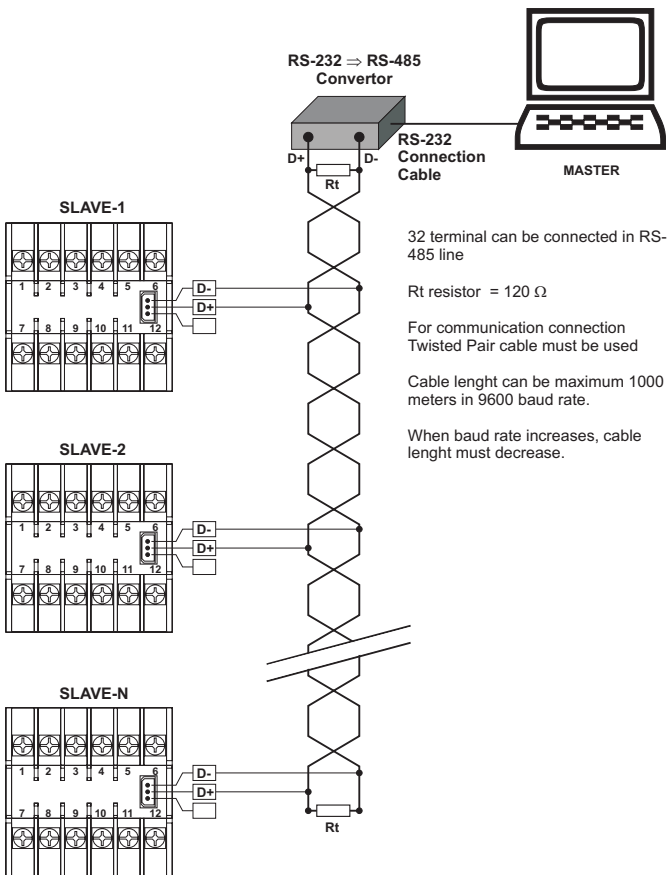

### 6.3 Installing RS-232 / RS-485 Serial Communication Modules to the Device

Pull the cover case with your hand through rear side as explained in "Installing and Pulling Out Output Modules" section. Pull the modules in Module-1 and Module-2 socket through rear side. Separate supply card which is at the bottom of the equipment by lifting the locking tabs located on front panel. Pay attention to cable connection between top and bottom cards. Damages in this cable makes the equipment not to work.

RS-232 or RS-485 module is plugged into socket signed as A and B. Hold the equipment to be its front panel is on your right, communication socket is on your left and module connection socket with 5 terminals on above. Plug in module connection socket with 5 terminals to the socket on Top Card. Do the same things for terminal socket in bottom card and connection socket with 3 terminals. Plug in bottom card to the place in front panel. Install the modules which are pulled out to Module-1 and Module-2 socket. Replace the cover case by taking care of the terminal numbers should be at right position.

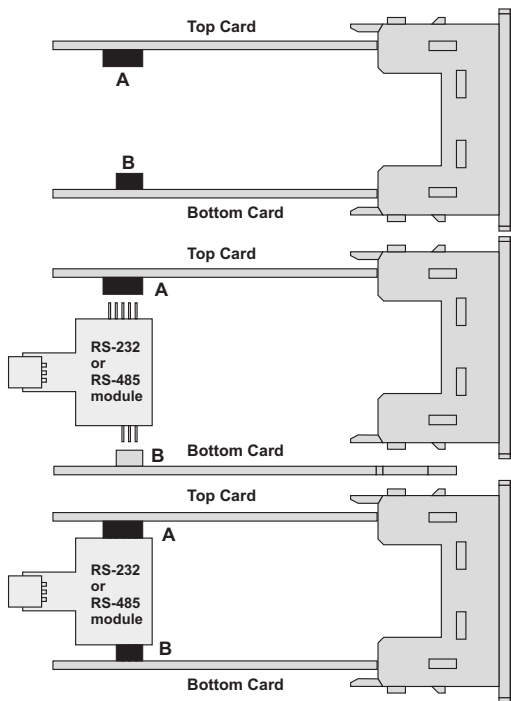

## 7. Definition of Front Panel and Accessing to the Parameters

### 7.1 Definition of Front Panel

#### LED indication of °C: Centigrade Unit

LED indication of °F  
Fahrenheit Unit

LED indication of units  
other than °C and °F

LED indication of  
Output-1 Status

LED indication of  
Output-2 Status

LED indication of  
Output-3 Status

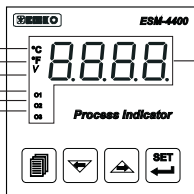

Displays  
Process Value (PV)  
and Parameter

**Menu button**  
This button is used  
to access to the all  
menus and to  
move up to another  
menu in the menu  
list

**Note-1**  
This button is used  
to decrease the  
values, access to  
the menu pages,  
cancel alarm  
latching

**Note-1**  
This button is used  
to increase the  
value and access to  
the menu pages

This button is used  
to access to the  
process set value  
and use as OK  
button in program  
parameters.

**Note-1:** If increment or decrement button is pressed for 5 seconds continuously, increment and decrement number become 10, if increment or decrement button is pressed for 10 seconds continuously, increment and decrement number become 100.



## 7.2 Observation of Optional Modules and Software Revision on the Displays

There are two sockets for plugging optional modules to the device. These modules are recognized by the device automatically. When the power is applied to the device all led indicators and display segments are momentarily illuminated for testing. Software revision number of the controller on the bottom display and module definition codes on the top display are momentarily illuminated. Module definition codes and how to observe these codes of optional modules in Module-1 and Module-2 socket are explained below :

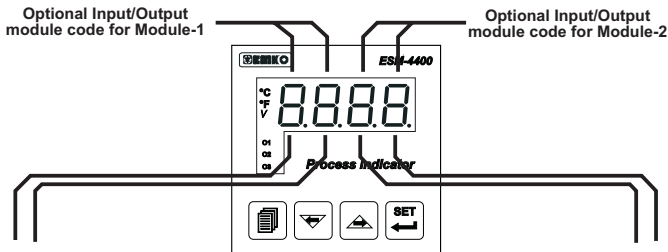
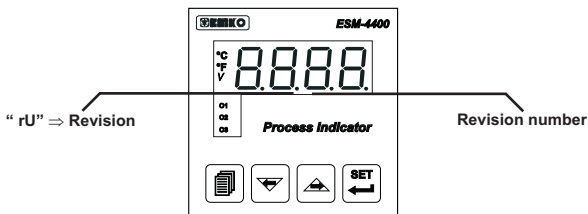

0r	Relay Output Module (EMO-400)	Relay Output Module (EMO-400)	0r
0S	SSR Driver and Digital Output Module (EMO-410 ,EMO-420)	SSR Driver and Digital Output Module (EMO-410 ,EMO-420)	0S
0A	0/4...20mA---Current Output Module (EMO-430)	0/4...20mA---Current Output Module (EMO-430)	0A
E	There is no module in Module-1 socket	There is no module in Module-2 socket	E

When power on, display of the indicator is like below:

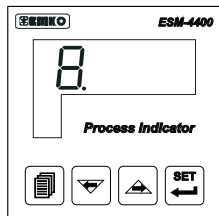

First segments of top and bottom displays are tested

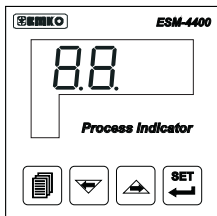

Second segments of top and bottom displays are tested.

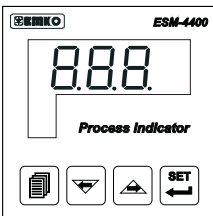

Third segments of top and bottom displays are tested.

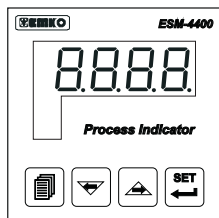

Fourth segments of top and bottom displays are tested.

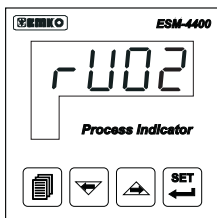

Revision number is shown. Revision number is "02".

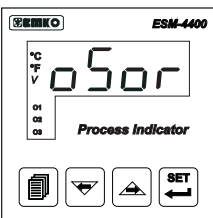

On display which modules are plugged in Module-1 and Module-2 socket is shown. All leds are energised. Above, there is EMO-410 SSR Driver Output module in Module-1 socket and EMO-400 Relay Output Module in Module-2 socket.

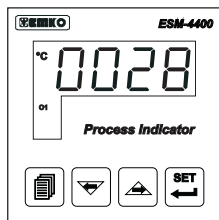

Main operation screen is shown



If there is an unexpected situation while opening the device, power off the device and inform a qualified personnel.

### 7.3 Adjustment of Alarm Set Values

If standard output ( Output-3 ) or any output module in Module-1 or Module-2 socket are configured as alarm output, how to access to these alarm set values are explained below:

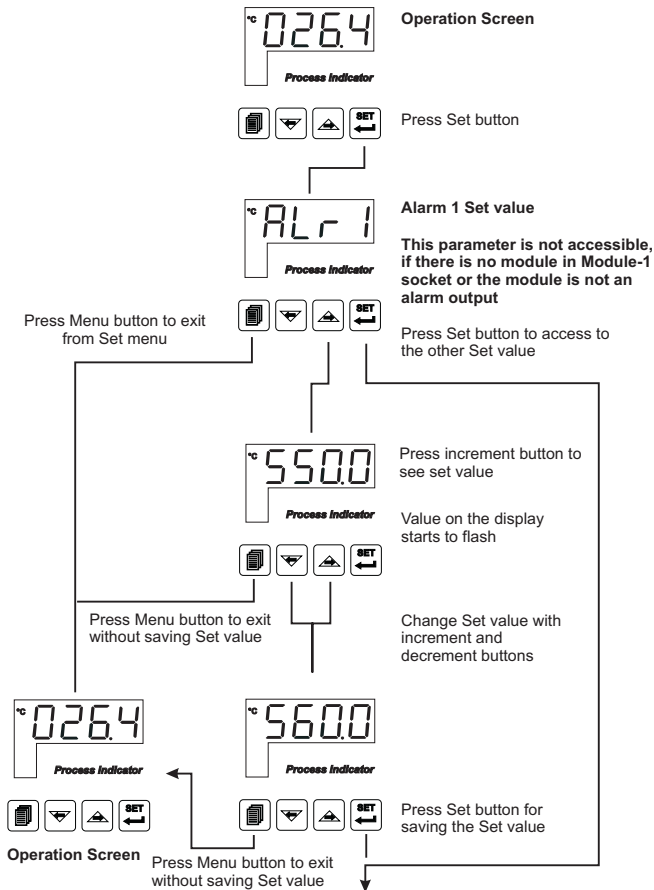

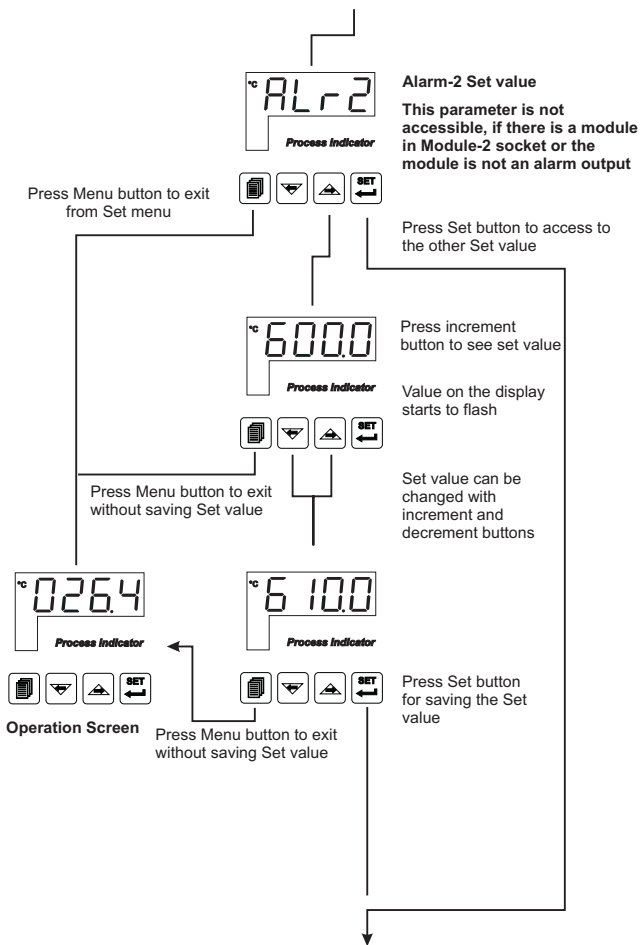

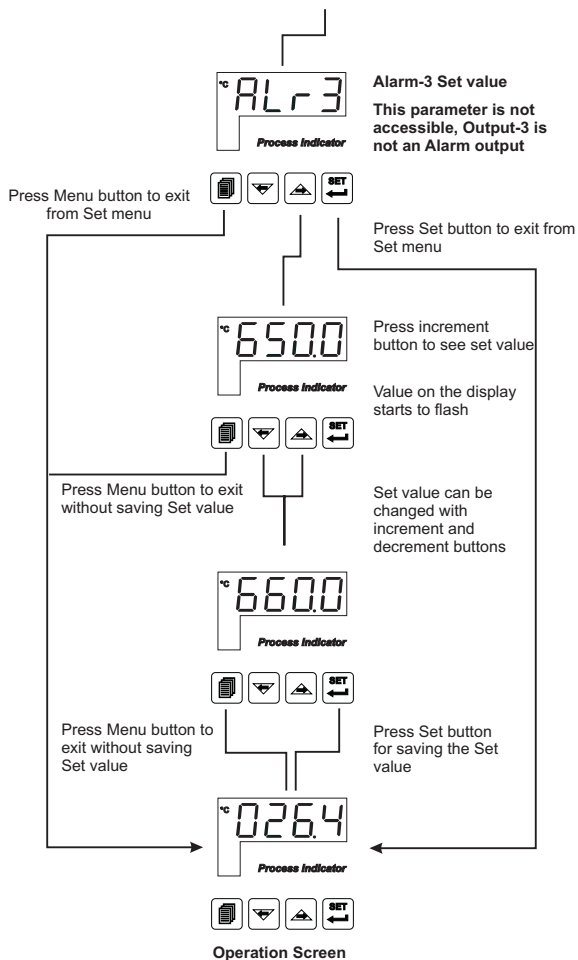

## 7.4 Accessing to the Technician Menu

The parameters have been divided into groups according to their functions. Every group has a title and firstly user must determine the title (menu) for accessing to the parameters. Refer to the parameters section for detailed information about parameters.

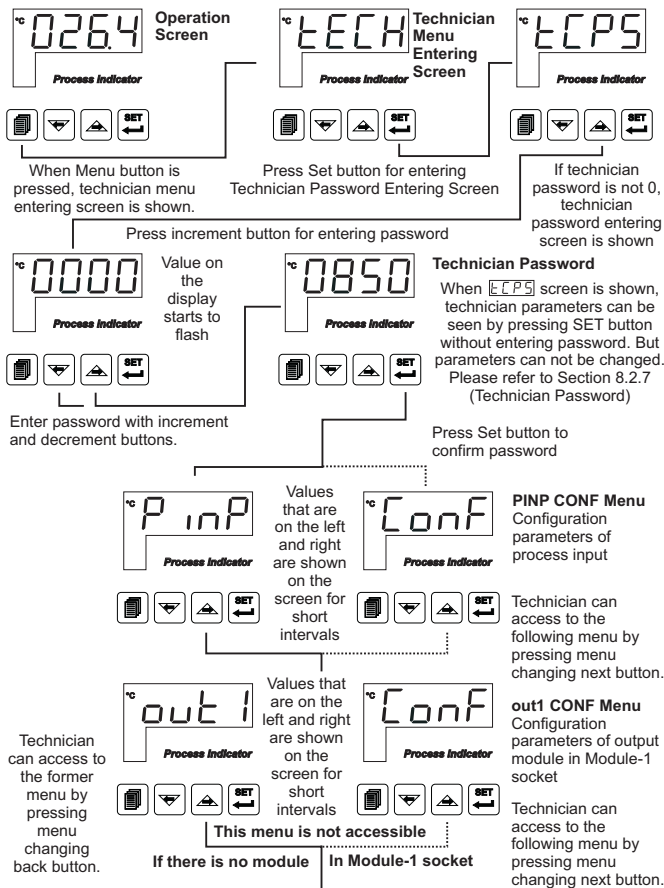

Technician can access to the former menu by pressing menu changing back button.

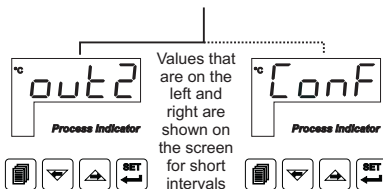

Values that are on the left and right are shown on the screen for short intervals

**out2 CONF Menu**  
Configuration parameters of output module in Module-2 socket

Technician can access to the following menu by pressing menu changing next button.

**This menu is not accessible**  
If there is no module In Module-2 socket

Technician can access to the former menu by pressing menu changing back button.

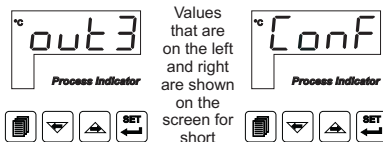

Values that are on the left and right are shown on the screen for short intervals

**out3 CONF Menu**  
Configuration parameters of Output-3

Technician can access to the following menu by pressing menu changing next button.

Technician can access to the former menu by pressing menu changing back button.

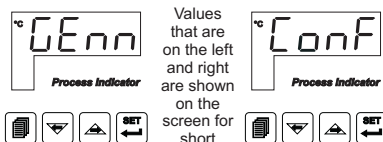

Values that are on the left and right are shown on the screen for short intervals

**GENN CONF Menu**  
General Parameters

Technician can access to the following menu by pressing menu changing next button.

Technician can access to the former menu by pressing menu changing back button.

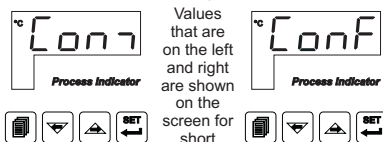

Values that are on the left and right are shown on the screen for short intervals

**COM CONF Menu**  
Configuration parameters of serial communication

Technician can access to the following menu by pressing menu changing next button.

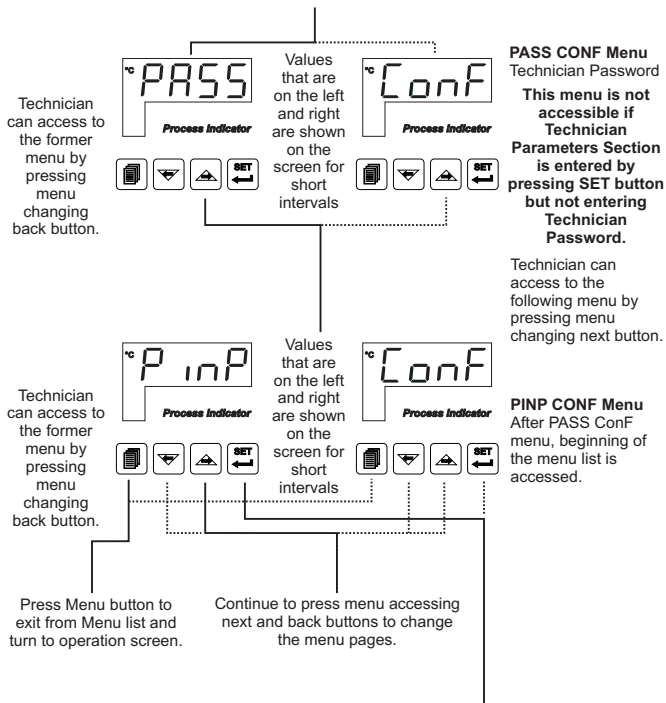

By pressing ENTER button, user accesses to the menu page and to all parameters in this menu page.



## 7.5 Changing and Saving Parameters

**Example-1 :** To change Process Input Type parameter [55L] in “PinP Conf” menu, user must access to PinP Conf menu firstly.

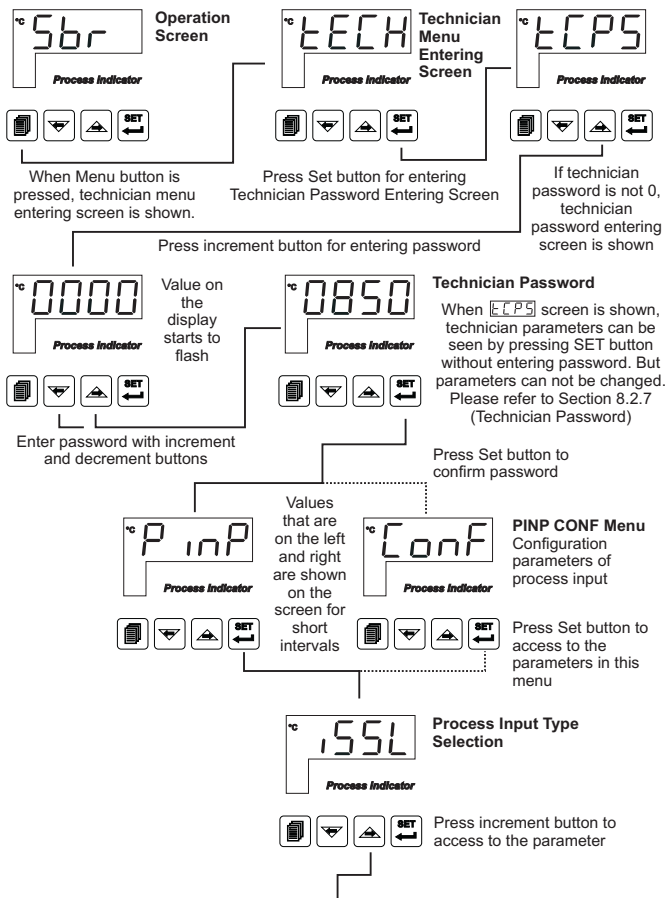

Value on the display starts to flash

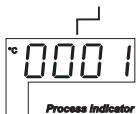

**Selection of Process Input Type**  
1.55L is 0001 means, input type is RTD.



Parameter can be changed with increment and decrement buttons

Value on the display flashes



**Process Input Type Selection**  
TC input type is selected



Press Set button to confirm the parameter and access to the next parameter



**TC Input Type Selection**



Press Set button to access to the next parameter

**PINP CONF Menu**  
Press Menu button to access to the menu pages



Values that are on the left and right are shown on the screen for short intervals



Press menu changing next or menu changing back button to access to the other menus

**Unit Selection**

If Menu button is pressed again, operation screen is shown.



**Operation Screen**



**EXAMPLE-2 :** To change Alarm Type parameter [AL3] in “out3 Conf” menu, user must access to out3 Conf menu firstly.

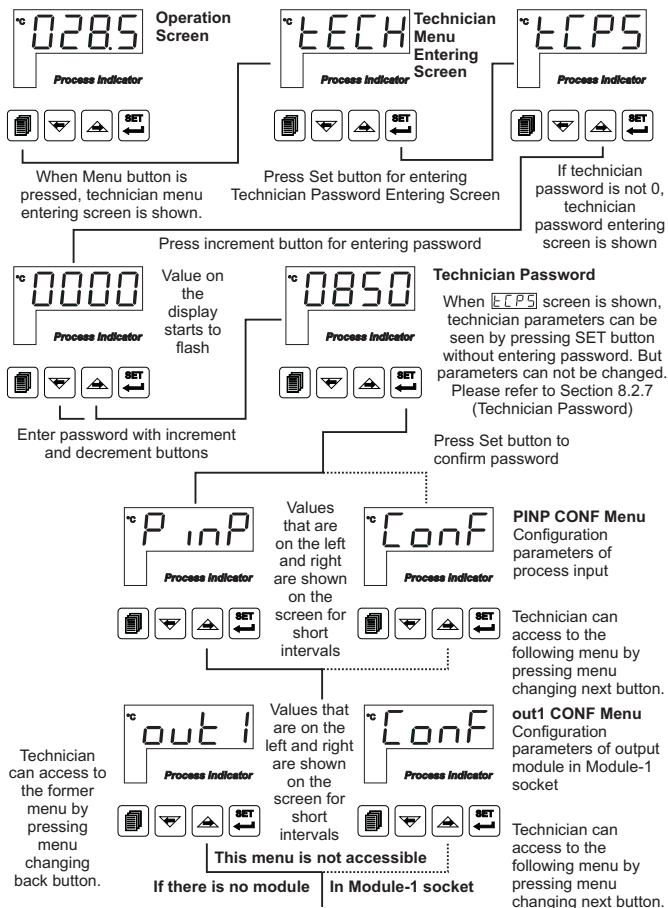

Technician can access to the former menu by pressing menu changing back button.

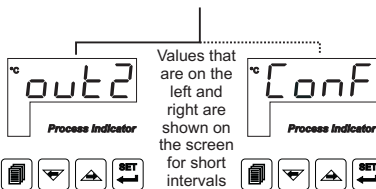

**out2 CONF Menu**  
Configuration parameters of output module in Module-2 socket

Technician can access to the following menu by pressing menu changing next button.

This menu is not accessible  
If there is no module In Module-2 socket

Technician can access to the former menu by pressing menu changing back button.

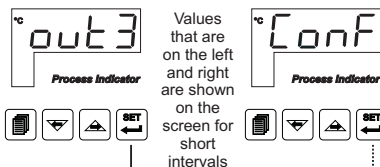

**out3 CONF Menu**  
Configuration parameters of Output-3

Press Set button to access to the parameter



**Logic Output Function Selection**

Logic Output Function Selection must be



Press Set button to access to the next parameter



**Alarm Type Selection**



Press increment button to access to the parameter

Value on the display starts to flash



**Alarm Type Selection**

Process high alarm



Parameter can be changed with increment and decrement buttons

Value on the display  
flashes



### Alarm Type Selection

Process low alarm



Press Set button to confirm  
the parameter and access to  
the next parameter



### Alarm Hysteresis Selection



Press Set button to access to  
the next parameter

### Out3 CONF Menu

Press Menu button to access to  
the menu pages

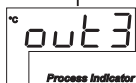

Values  
that are  
on the left  
and right  
are shown  
on the  
screen for  
short  
intervals



Continue to press menu accessing next and  
back buttons to change the menu pages.

### Alarm on Delay Time

If Menu button is pressed again,  
operation screen is shown.



### Operation Screen

**Example-3 :** To change  $\equiv$  Voltage/Current Input Calibration Type parameter  $\square$  in "PinP Conf" menu

$\square$  Parameter is on "PinP Conf" menu. For accessing to this parameter, technician must access to "PinP Conf" menu firstly. In this example, changing input type of a device from thermocouple to  $\equiv$  Voltage/Current and dual point calibration selection is shown.

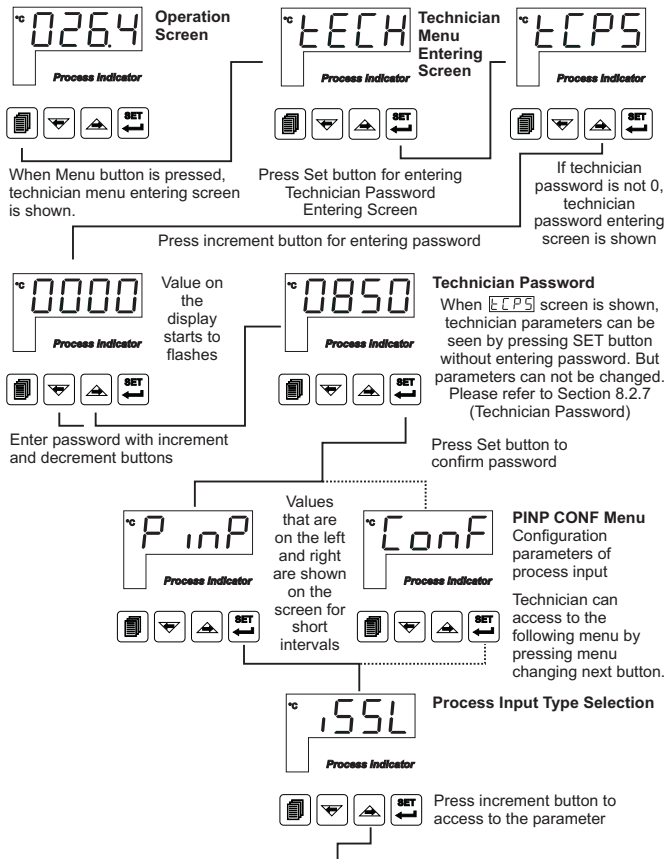

Value on the display starts to flash

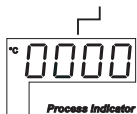

### Process Input Type Selection



Parameter can be changed with increment and decrement buttons

Value on the display flashes



### Process Input Type Selection

For accessing to  $\square$ CAL Parameter,  $\square$ SSL parameter Must be  $\square$ 0002 If it is not  $\square$ 0002 change the parameter as  $\square$ 0002 With increment button



Press Set button to confirm the value and access to the next parameter

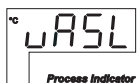

### voltage / Current Input Type Selection



Press Set button to access to the next parameter



### Decimal Point Position



Press Set button to access to the next parameter



### voltage / Current Input Calibration Type Selection



Press increment button to access to the parameter

Value on the display starts to flash

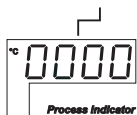

---voltage / Current Input  
Calibration Type Selection



Parameter can be changed with increment and decrement buttons

Value on the display flashes



---voltage / Current Input  
Calibration Type Selection



Press Set button to confirm the parameter and access to the next parameter

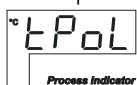

Minimum value for selectable dual point calibration



Press Set button to access to the next parameter

### PINP CONF Menu

Press Menu button to access to the menu pages



Values that are on the left and right are shown on the screen for short intervals



Continue to press menu accessing next and back buttons to change the menu pages.

Maximum value for selectable dual point calibration

If Menu button is pressed again, operation screen is shown.



Operation Screen





## 8. Parameters

Parameters are divided into two groups. These are Alarm Set and Technician parameters. Technician parameters are grouped into subgroups according to their functions. The subgroups are named as menu pages.

### 8.1 Alarm SET Parameters



EMO-400  
EMO-410  
EMO-420

ALr1

If EMO-400 Relay, EMO-410 SSR Driver or EMO-420 Digital (Transistor) output module is plugged in Module-1 socket and output is configured as an alarm output, this parameter defines the set value of the alarm output.

ALr1 Set value can be adjusted from minimum value of set scale  $\overline{5U-L}$  To maximum value of set scale  $\overline{5U-U}$



EMO-400  
EMO-410  
EMO-420

ALr2

If EMO-400 Relay, EMO-410 SSR Driver or EMO-420 Digital (Transistor) output module is plugged in Module-2 socket and output is configured as an alarm output, this parameter defines the set value of the alarm output.

ALr2 Set value can be adjusted from minimum value of set scale  $\overline{5U-L}$  To maximum value of set scale  $\overline{5U-U}$

ALr3

If OUT-3 relay output module is configured as alarm output, this parameter defines the set value of the alarm output.

ALr3 Set value can be adjusted from minimum value of set scale to maximum value of set scale

P<sub>inP</sub>  
Conf

## 8.2.1 Process Input Type and Relevant Parameters with Process Input

155L Defines the process input type.

0000 TC input type selection

0001 RTD input type selection

0002 ---Voltage/Current input type selection.

155L  
0000

EE5L Defines type and scale of the thermocouple for TC input. It is active if TC input type is selected.

0000 L (-100°C;850°C) or (-148°F;1562°F)

0001 L (-100.0°C;850.0°C) or (-148.0°F;999.9°F)

0002 J (-200°C;900°C) or (-328°F;1652°F)

0003 J (-199.9°C;900.0°C) or (-199.9°F;999.9°F)

0004 K (-200°C;1300°C) or (-328°F;2372°F)

0005 K (-199.9°C;999.9°C) or (-199.9°F;999.9°F)

0006 R (0°C;1700°C) or (32°F;3092°F)

0007 R (0.0°C;999.9°C) or (32.0°F;999.9°F)

0008 S (0°C;1700°C) or (32°F;3092°F)

0009 S (0.0°C;999.9°C) or (32.0°F;999.9°F)

0010 T (-200°C;400°C) or (-328°F;752°F)

0011 T (-199.9°C;400.0°C) or (-199.9°F;752.0°F)

0012 B (44°C;1800°C) or (111°F;3272°F)

0013 B (44.0°C;999.9°C) or (111.0°F ; 999.9°F)

0014 E (-150°C;700°C) or (-238°F;1292°F)

0015 E (-150.0°C;700.0°C) or (-199.9°F;999.9°F)

0016 N (-200°C;1300°C) or (-328°F;2372°F)

0017 N (-199.9°C;999.9°C) or (-199.9°F;999.9°F)

0018 C (0°C;2300°C) or (32°F;3261°F)

0019 C (0.0°C;999.9°C) or (32.0°F;999.9°F)

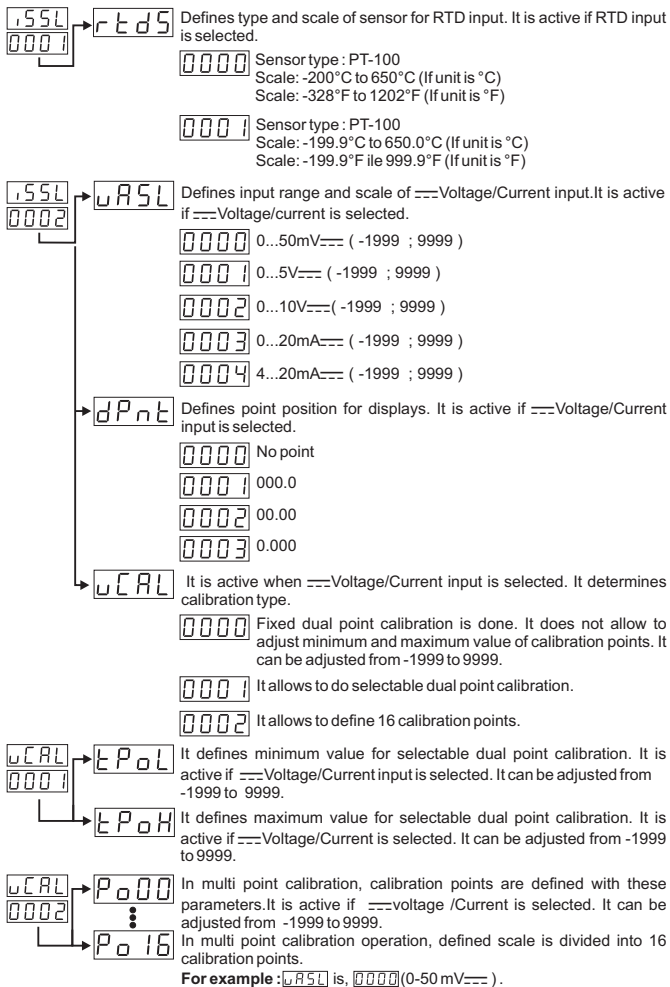

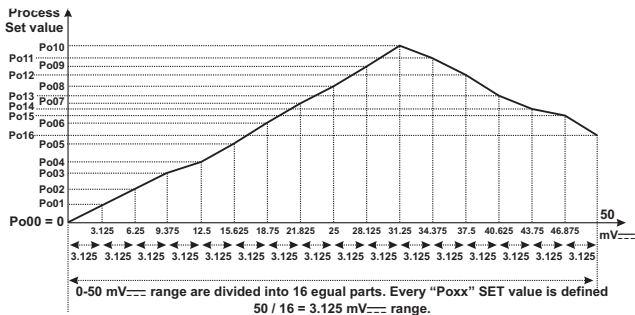

**COEF**

Coefficient value for ---Voltage /Current input. Process value is multiplied with this value.

It is active if ---voltage /Current input is selected. It can be adjusted from 1.000 to 9.999.

**unit**

Unit selection

Unit is °C

Unit is °F

**U**

Unit is U. It is active if ---voltage /Current input is selected

No unit. It is active if ---Voltage/Current input is selected

**LoL**

Minimum value of operating scale. It can be changed according to input type and scale of the process.

**uPL**

Maximum value of operating scale. It can be changed according to input type and scale of the process.

**PUoF**

Display offset for process value. It can be adjusted -10% to +10% of scale. The defined value is added to process value.

**IFLT**

Defines filter time for input signal. It can be adjusted from 0.0 to 900.0.

**CJnC**

It is active if process input is selected TC input. It decides if cold junction compensation is active or not.

Cold junction compensation is active.

Cold junction compensation is not active.

out |  
Conf

## 8.2.2 MODULE-1 Configuration Parameters

Module-1 configuration parameters are arranged automatically by the device according to the module type in Module-1 socket. These parameters are not accessible if there is no module in Module-1 socket.

EMO-400, EMO-410 EMO-420	Low	It determines logic output function of the output module in Module-1 socket
	ALt	Defines alarm type
	ALH	Alarm-1 hysteresis value
	Ron	Alarm on delay time
	RoF	Alarm off delay time
EMO-430	oRt	Configuration of analogue output module

Module-1 configuration parameters are defined according to which output modules are plugged in Module-1 socket.

out | Conf



These parameters are active if EMO-400 (Relay Output), EMO-410 (SSR Driver) or EMO-420 (Digital Output) module is plugged in Module-1 socket.

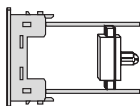

EMO - 400  
EMO - 410  
EMO - 420

out |  
Conf

Low | It determines logic output function of the output module in Module-1 socket

0000 Alarm output

0001 Sensor break alarm output

0002 Output is active when the process value is out of the band which is defined with minimum value of operating scale Lo And maximum value of operating scale uPl

Low |  
0000

ALt | It determines alarm type. It is active if logic output function of Module-1 is adjusted alarm output.

0000 Process high alarm

0001 Process low alarm

## Process high alarm

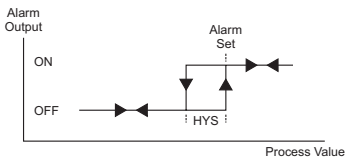

## Process low alarm

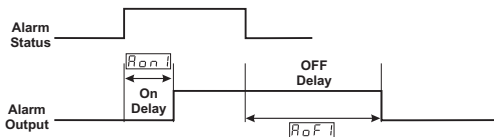
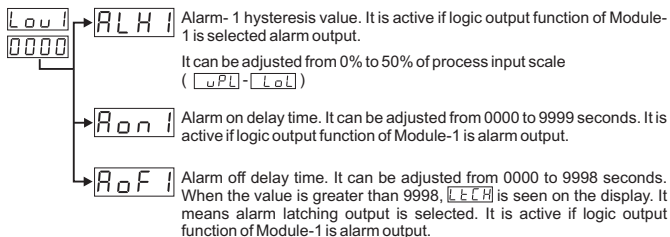
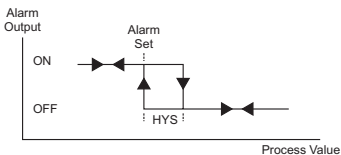

out 1 Conf



These parameters are active if EMO-430 (0/4...20 mA---Current Output) module is plugged in Module-1 socket.

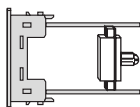

EMO-430

out 1

Conf

oAt 1

Configuration of analogue output module in Module-1 socket.

0000

0...20mA output or 0...10V--- according to Section 5.1.5 is selected.

0001

4...20mA output or 2...10V--- according to Section 5.1.5 is selected.

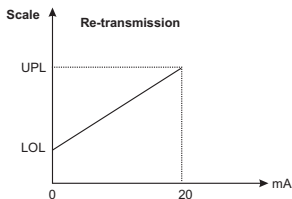

out2  
Conf

### 8.2.3 MODULE-2 Configuration Parameters

Module-2 configuration parameters are arranged automatically by the device according to the module type in Module-2 socket. These parameters are not accessible if there is no module in Module-2 socket.

EMO-400, EMO-410 EMO-420	out2	It determines logic output function of the output module in Module-2 socket
	ALt2	Defines alarm type
	ALH2	Alarm-2 hysteresis value
	AOnd	Alarm on delay time
	AOFd	Alarm off delay time
EMO-430	oAt2	Configuration of analogue output module

Module-2 configuration parameters are defined according to which output modules are plugged in Module-2 socket.

out2 Conf



These parameters are active if EMO-400 (Relay Output), EMO-410 (SSR Driver) or EMO-420 (Digital Output) module is plugged in Module-2 socket.

out2  
Conf

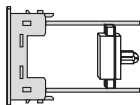

EMO - 400  
EMO - 410  
EMO - 420

out2  
Conf

out2 It determines logic output function of the output module in Module-2 socket

0000 Alarm output

0001 Sensor break alarm output

0002 Output is active when the process value is out of the band which is defined with minimum value of operating scale [Lo] And maximum value of operating scale [uPl]

out2  
0000

ALt2 It determines alarm type. It is active if logic output function of Module-2 is adjusted alarm output.

0000 Process high alarm

0001 Process low alarm



## Process high alarm

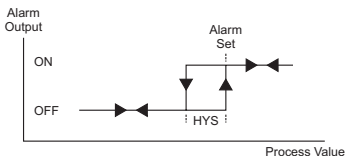

## Process low alarm

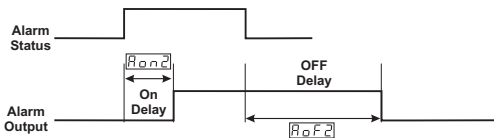
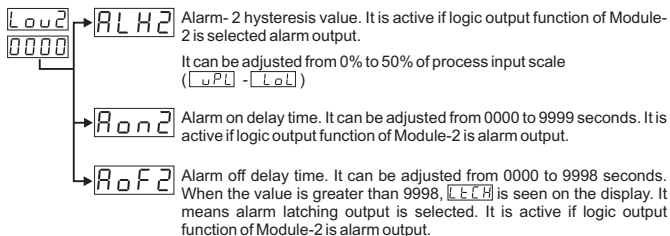
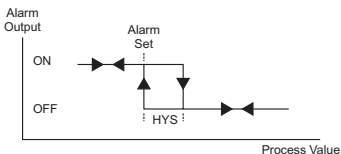

out2 Conf



These parameters are active if EMO-430 (0/4...20 mA ---Current Output) module is plugged in Module-2 socket.

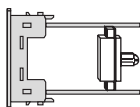

EMO-430

out2

Conf

oAt2

Configuration of analogue output module in Module-2 socket.

0000

0...20mA output or 0...10V--- according to Section 5.1.5 is selected.

0001

4...20mA output or 2...10V--- according to Section 5.1.5 is selected.

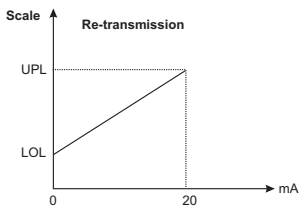

out3  
Conf

## 8.2.4 OUTPUT-3 Configuration Parameters

LOU3 It determines logic output function of Output-3

0000 Alarm output

0001 Sensor break alarm output

0002 Output is active when the process value is out of the band which is defined with minimum value of operating scale [LOL] And maximum value of operating scale [UPL]

LOU3 → ALT3 It determines alarm type. It is active if logic output function of Output-3 is alarm output.

0000

0000 Process high alarm

0001 Process low alarm

### Process high alarm

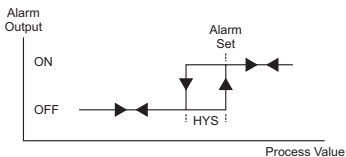

### Process low alarm

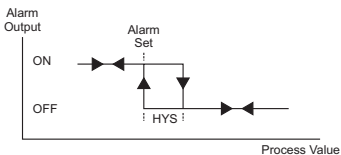

LOU3 → ALH3 Alarm-3 hysteresis value. It is active if logic output function of Output-3 is alarm output.

0000

It can be adjusted from 0% to 50% of process input scale ([UPL] - [LOL])

LOU3 → AON3 Alarm on delay time. It can be adjusted from 0000 to 9999 seconds. It is active if logic output function of Output-3 is alarm output.

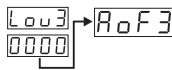
 Alarm off delay time. It can be adjusted from 0000 to 9998 seconds. When the value is greater than 9998, **LEH** is seen on the display. It means alarm latching output is selected. It is active if logic output function of Output-3 is alarm output.

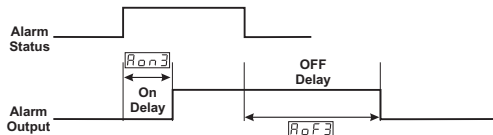

Gen  
Conf

## 8.2.5 General Parameters

**SU-L** Minimum value for process set and alarm set values. It is named as low limit of set scale.  
It can be adjusted from low limit of input selected with **LSL** parameter to **SU-u** parameter.  
Please refer to Section 8.2.1 Process Input Type and Relevant Parameters with Process Input for **LSL** parameter

**SU-u** Maximum value for process set and alarm set values. It is named as high limit of set scale.  
It can be adjusted from **SU-L** to high limit of input selected with **SSL** Parameter.  
Please refer to Section 8.2.1 Process Input Type and Relevant Parameters with Process Input for **SSL** parameter

Conf  
Conf

## 8.2.6 Parameters for Configuration of Serial Communication

**SAdr** Communication Accessing Address

Communication accessing address of device. It can be adjusted from 1 to 247.

**bAud** Communication Baud Rate

**0000** 1200 Baud Rate

**0001** 2400 Baud Rate

**0002** 4800 Baud Rate

**0003** 9600 Baud Rate

**0004** 19200 Baud Rate

**PrtY** Parity Selection for Communication

**0000** No parity

**0001** Odd Parity

**0002** Even Parity

**StPb** Stop Bit Selection for Communication

**0000** 1 Stop Bit

**0001** 2 Stop Bits

PASS  
CONF

## 8.2.7 Technician Password

EEPS It is used for accessing to the technician parameters.  
It can be adjusted from 0 to 9999.

If it is 0000 ; there is no password protection while entering to the technician parameters.

**If it is different from “ 0” and user wants to access to the technician parameters;**

1- If user does not enter EEPS password correctly:

It turns to operation screen without entering to operator parameters.

2- When EEPS in top display and 0000 in bottom display, if user presses SET button without entering EEPS password (For observing parameters)

User can see all menus and parameters except Operator and Technician Password menu (“Pass Conf”) but parameters can not be changed.

( Please refer to Section 9. Failure Messages (4) in ESM-4400 Process Indicators )

## 9. Failure Messages in ESM-4400 Process Indicator



1 - Sensor failure in analogue inputs. Sensor connection is wrong or there is no sensor connection.



2 - If display blinks : If analogue input value is less than minimum value of operating scale  $\boxed{\text{LoL}}$  display starts to blink.



In "PinP Conf" Menu if;

$\boxed{.55L} \Rightarrow \boxed{0000}$ ;  $\boxed{E.C5L} \Rightarrow \boxed{0003}$ ;  $\boxed{\text{unit}} \Rightarrow \boxed{\phantom{0}}$ ;  
 $\boxed{\text{LoL}} \Rightarrow \boxed{4999}$ ;  $\boxed{\text{uPL}} \Rightarrow \boxed{9000}$  are defined.

Adjust  $\boxed{\text{LoL}} \Rightarrow \boxed{4500}$

If analogue input value is less than minimum value of operating scale  $\boxed{\text{LoL}}$  Display starts to blink.



 Please refer to Section 8.2.1 for detailed information about this parameter.



3 - If display blinks : If analogue input value is greater than maximum value of operating scale  $\boxed{\text{uPL}}$ , display starts to blink.



In "PinP Conf" Menu ;

$\boxed{.55L} \Rightarrow \boxed{0000}$ ;  $\boxed{E.C5L} \Rightarrow \boxed{0003}$ ;  $\boxed{\text{unit}} \Rightarrow \boxed{\phantom{0}}$ ;  
 $\boxed{\text{LoL}} \Rightarrow \boxed{4999}$ ;  $\boxed{\text{uPL}} \Rightarrow \boxed{9000}$

Adjust  $\boxed{\text{uPL}} \Rightarrow \boxed{8500}$

If analogue input value is greater than maximum value of operating scale  $\boxed{\text{uPL}}$ , display starts to blink.



 Please refer to Section 8.2.1 for detailed information about this parameter.



4 - If technician password is different from "0" and user accesses to the parameter by Set button without entering the technician password and wants to change a parameter, the warning message is shown on the bottom display as shown on the left. Device does not allow to do any changes without entering the password correctly.

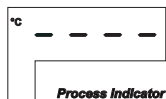

5 - If user does not do anything for 120 seconds while device is on Set or Technician menus, device turns to operation screen.





## 10. Specifications

<b>Device Type</b>	: Process Indicator
<b>Housing&amp;Mounting</b>	: 48mm x 48mm x 116mm 1/16 DIN 43700 plastic housing for panel mounting. Panel cut-out is 46x46mm.
<b>Protection Class</b>	: NEMA 4X (IP65 at front, IP20 at rear).
<b>Weight</b>	: Approximately 0.21 Kg.
<b>Environmental Ratings</b>	: Standard, indoor at an altitude of less than 2000 meters with none condensing humidity.
<b>Storage/Operating Temperature</b>	: -40 °C to +85 °C / 0 °C to +50 °C
<b>Storage/Operating Humidity</b>	: 90 % max. (None condensing)
<b>Installation</b>	: Fixed installation
<b>Over Voltage Category</b>	: II
<b>Pollution Degree</b>	: II, office or workplace, none conductive pollution
<b>Operating Conditions</b>	: Continuous
<b>Supply Voltage and Power</b>	: 100 - 240 V ~ (-15% / +10%) 50/60 Hz. 6VA 24 V ~ (-15% / +10%) 50/60 Hz. 6VA 24 V = (-15% / +10%) 6W 12 V = (-15% / +10%) 6W
<b>Process Inputs</b>	: Universal input TC, RTD, = Voltage/Current
<b>Thermocouple Input Types</b>	: Selectable by parameters L (DIN43710) , J ,K ,R ,S ,T ,B ,E ,N (IEC584.1)(ITS90) , C (ITS90)
<b>Thermoresistance Input Types</b>	: PT 100 (IEC751) (ITS90)
<b>= Voltage Input Types</b>	: Selectable by parameters 0...50mV =, 0...5V =, 0...10V =
<b>= Current Input Types</b>	: Selectable by parameters 0...20mA =, 4...20mA =
<b>Accuracy</b>	: ± 0,25% of full scale for thermocouple, thermoresistance and voltage, ± 0,70% of full scale for current.
<b>Cold Junction Compensation</b>	: Automatically ± 0.1°C/1°C.
<b>Line Compensation</b>	: Maximum 10 Ω .
<b>Sensor Break Protection</b>	: Upscale
<b>Sampling Cycle</b>	: 3 samples per second
<b>Input Filter</b>	: 0.0 to 900.0 seconds
<b>Control Forms</b>	: Programmable ON / OFF
<b>Standard Relay Output</b>	: 5A@250V~ (Programmable control or alarm output) (Electrical Life : 100.000 Operation (Full Load))
<b>Optional Output Modules</b>	:-EMO-400 Relay Output Module (3A@250V~) -EMO-410 SSR Driver Output Module (Max20mA@18V = ) -EMO-420 Digital (Transistor) Output Module (Max 40mA@18V =) -EMO-430 0/4...20mA = Current Output Module
<b>Standard Communication Module</b>	: EMC-400 RS-232 Communication Module
<b>Optional Communication Module</b>	: EMC-410 RS-485 Communication Module
<b>Communication Protocol</b>	: MODBUS-RTU
<b>Process Display</b>	: 10 mm Red 4 digit LED display
<b>Led Indicators</b>	: O1 / 2 / 3 (Outputs) LEDs, °C / °F / V unit LEDs