

Features

- Current:0.5A~400A
- Voltage:12V~680V
- Small General outline Vacuum Weld Technics
- Make R/C(MOV) inside could absorb out ITSM
- Led indicator showing "ON" or "OFF"
- Clarity protect Panel
- IEC standard
- Input & output type could chose
- DC/AC AC/AC DC/DC AC/DC

Typical Applications

- AC DC switch & Temp control
- Automate Control
- Numerical Control Machinery

Introduction

Solid State Relay(SSR) is industrial control appliances which use power semiconductor devices for main control part, compare with traditional magnetic contact industrial controllers, it is more high-powered, intelligent, digital, systematic and green development.

according switch mode SSR have zero-cross and random type. When the input control signal, random type conduction immediately, zero cross type need load voltage turn to zero region just can conduction. Revocation of the control signal,all can cut off when less than maintenance current. zero cross type may cause the maximum half-cycle delay, but reduces the impact of the load and radiofrequency interference, is the ideal switching devices.Random type fast response,suitable for dimmer,thermostats resistive loads and some inductive load applications.

When the SSR turn off, if in the phase current and voltage have different, will have a large rise rate (dv/dt) on the triac, such as dv/dt higher than Triac standatrd (300V/us), will result in delay shutdown even failure. use anti-parallel thyristor's SSR(powerful type) will be greatly improved at dv/dt(dv / dt is 500V/us). Therefore, in the field of capacitive load or inductive load, suggest the use powerful type SSR. Zenli's SSR >40A, all use powerful type.

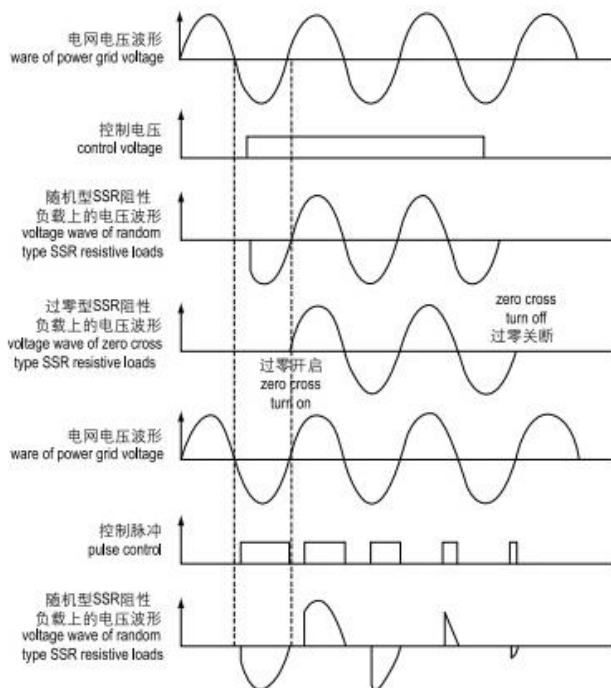

Ordering Information Table

Device Code	SSR	-	D	48	40	R	1
	①		②	③	④	⑤	⑥
1	-ZENLI Solid state relay						
2	-D=DC to AC (DC3-32V)						
	A=AC to AC V=Voltage regulator						
	HD=Industry standard DC/AC 3P=3-phase DC/AC						
3	-Rated operational voltage, code × 10(48 × 10=480V)						
4	-Rated operational current						
5	-None=Zero cross trigger						
	R=Random switch						
6	-Outline: None=crydom type, black cover						
	1=FOTEK type, white cover 2=OMRON type, grey cover						

固态继电器是以电力半导体器件为主功率器件的工业控制电器,它与传统的电磁接触式工业控制器相比较,更符合电力电气设备朝着高性能,智能化,数字化,系统化及绿色化发展的要求。

固态继电器按照开关方式分为过零导通型和随机导通型。当输入控制信号后,随机型能立即导通,过零型要等到负载电压过零区域才能导通。撤销控制信号后,都在小于维持电流时关断。过零型有可能造成最大半个周期的延时,却减小了对负载的冲击和射频干扰,是理想的开关器件。随机性特点是反应快,适合应用于调光调温等阻性负载和部分感性负载场合。

当SSR由导通到关断时,由于电流电压的相位不一致,将产生一个很大的电压上升率(dv/dt)在双向可控硅上,如上升率超过双向可控硅的换向dv/dt指标(标准为300V/us),将导致延时关断甚至失败。由2只单向可控硅反并联构成的增强型SSR比普通由1只双向可控硅构成的SSR的换向dv/dt有很大的提高(dv/dt值为500V/us)。因此在感性负载或容性负载领域建议选用增强型SSR。我司40A以上均为增强型。



SSR-D Series Solid State Relay (DC-AC) 直流控制交流系列固态继电器SSR-D

Rated load current	Operating voltage	Min. ON voltage	Min. OFF voltage	Open current	Load voltage	dv/dt	Voltage drop	Peak current	Leakage current	Turn-on time	Turn-off time	Insulation voltage	Tj	Outline
A	V	V	V	12V	V	V/ μ s	V	A	mA	ms	ms	V	$^{\circ}$ C	
10	3-32	> 2.4	< 1.0	6.25	300	≤ 1.5	2.0	135	3.0	10	10	2500	-30 $^{\circ}$ C ~ +80 $^{\circ}$ C	SSR1/2
25	3-32	> 2.4	< 1.0	6.25	300	≤ 1.5	2.0	275	3.0	10	10	2500		
40	3-32	> 2.4	< 1.0	6.25	300	≤ 1.5	2.0	410	3.0	10	10	2500		
60	3-32	> 2.4	< 1.0	6.25	500	≤ 1.5	2.0	635	3.0	10	10	2500		
80	3-32	> 2.4	< 1.0	6.25	500	≤ 1.5	2.0	850	3.0	10	10	2500		
100	3-32	> 2.4	< 1.0	6.25	500	≤ 1.5	2.0	990	3.0	10	10	2500		

SSR-A Series Solid State Relay (AC to AC) 交流控制交流系列固态继电器SSR-A

Rated Load current	Operating voltage	Min.on voltage	Min.off voltage	Triggert current	Load voltage	Block voltage	Voltage drop	Peak current	Leakage current	Turn-on time	Turn-off time	Insulation voltage	Tj	Outline
A	V	V	V	mA	V	V	V	A	mA	ms	ms	V	$^{\circ}$ C	
10	90-280	> 50	< 45	8.0(<110V)	24-240	600	2.0	135	3.0	20	20	2500	-30 $^{\circ}$ C ~ +80 $^{\circ}$ C	SSR1/2
25	90-280	> 50	< 45	8.0(<110V)	24-240	600	2.0	275	3.0	20	20	2500		
40	90-280	> 50	< 45	8.0(<110V)	24-240	600	2.0	410	3.0	20	20	2500		
60	90-280	> 50	< 45	8.0(<110V)	24-240	600	2.0	635	3.0	20	20	2500		
80	90-280	> 50	< 45	8.0(<110V)	24-240	600	2.0	850	3.0	20	20	2500		
100	90-280	> 50	< 45	8.0(<110V)	24-240	600	2.0	990	3.0	20	20	2500		

SSR-V Series Solid State Voltage Regulator 固态调压器SSR-V

Rated Load current	Variable resistance	Operating voltage	Block voltage	Voltage drop	Peak current	Leakage current	Dielectric strength	Peak current	Insulation sttength	Tj	Outline
A	K Ω	V	V	V	A	mA	V	A	M Ω /VDC	$^{\circ}$ C	
10	0-470	24-380	600	2.0	135	5.0	2500	135	50/500	-30 $^{\circ}$ C ~ +80 $^{\circ}$ C	SSR1/2
25	0-470	24-380	600	2.0	275	5.0	2500	275	50/500		
40	0-470	24-380	600	2.0	410	5.0	2500	410	50/500		
10	0-560	24-380	600	2.0	135	5.0	2500	135	50/500		
25	0-560	24-380	600	2.0	275	5.0	2500	275	50/500		
40	0-560	24-380	600	2.0	410	5.0	2500	410	50/500		

Solid State Relay Outline 固态继电器外形图

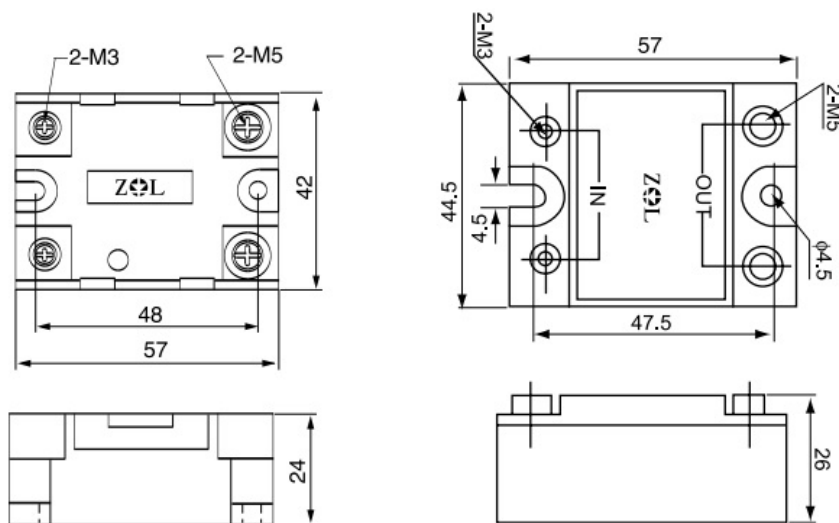

SSR-1

SSR-2

Solid State Relay Heatsink 固态继电器用散热器

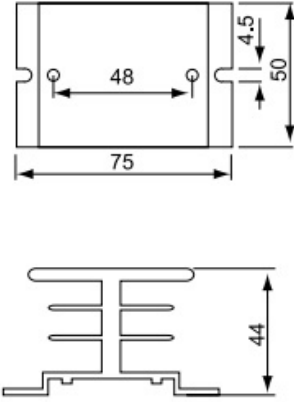

ZLXC-SSR1(10-60A)

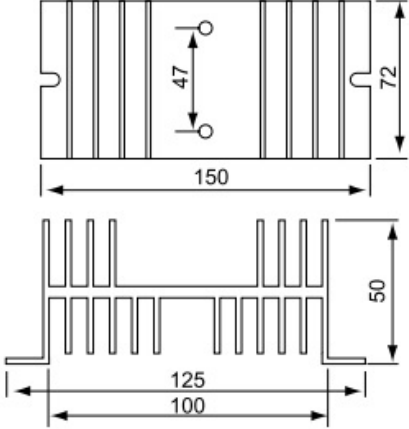

ZLXC-SSR2(40-120A)