

FT3419/FT3419P High-Precision Digital Temperature Controller/Regulator

1. Main features

- DIN48×48mm, new generation of high-end controller, large window, high contrast LCD and easy to read white PV display, which improves the visibility of all angles and achieve long-distance visibility.
- The front panel has good waterproof performance. Plastic handle waterproof button, the button operating surface strong, scratch-resistant and wear-resistant, operation feel clear and smooth.
- Universal input: support all kinds of thermocouples, RTDs, linear voltage/current, resistance and radiation (infrared) thermometer signals are selectable.
- The high precision special A/D acquisition chip is used to measure accurately and display stably, 80ms high-speed sampling period, the measurement accuracy is up to 0.1% level.
- The output specification is rich and diversified, and it can be selected to meet more control applications.
- Advanced "FUZZY+PID" ai intelligent control mode, no overshoot and with the function of auto tuning (AT) and self-adaptation.
- Can provide up to Three alarm output and LBA control circuit disconnection alarm function.
- Support RS485 or RS232C communication interface, and MODBUS RTU communication protocol.
- The measured value (PV) or a set value (SV) can be changed into a standard current signal output, which can be used as a temperature transmitter.
- It can realize 1 way PID control output + 1 way PV value analog output.
- The third display window can be enabled for Can manual / automatic switch control.
- Application is very wide, suitable for temperature, humidity, pressure, flow, liquid level, pH value of the precise measurement / control.
- High-efficiency and high-reliability switching power supply, global universal voltage range AC100~240V or AC/DC12~24V.
- The anti-interference performance has reached the high standard level of EMC.

2. Technical Specification

Size	Panel size: 48x48mm, opening size: 45x45mm
Installation mode	Embedded Installation and Guideway Installation
Indication method	7-segment digital LCD display and individual indicators
Power supply voltage	AC100~240V (-15%, +10%) 50-60HZ, or AC/DC12~24V(-15%, +10%)
Power consumption	Approx. 5.2 VA at 100 to 240 VAC, Approx. 3 VA at 12 to 24 VDC
Input specification and scope	Thermocouple: K(-50~+1300°C), S(-50~+1700°C), R(-50~+1700°C), T(-200~+350°C), E(0~800°C), J(0~1000°C), B(200~1800°C), N(0~1300°C), WRe3-WRe25(0~2300°C), WRe5-WRe26(0~2300°C). RTDs: Cu50(-50~+150°C), Pt100(-200~+600°C). Linear voltage/current: 0~5V, 1~5V, 0~1V, 0.2~1V, 0~20mV, 0~60mV, 0~75mV, 0~100mV, -5~+5V, -1V~+1V, -20mV~+20mV, -100~+100mV, 0~20mA, 4~20mA etc. Linear Input: -9990~32000 defined by user
Measurement accuracy	0.1% FS ± 1 measurement unit(RTDs, voltage, current and thermocouple Input use external copper resistance compensation or ice point compensation cold end), 0.1%FS + 2 degrees(Thermocouple Input use instrument internal components temperature compensation cold end)
Decimal point	0/0.0/0.00/0.000(set by dP parameter)
Response time	80mS(when digital filter parameter InF=0), Display response times≤0.3Sec
Control mode	ON-OFF(one-stop) control mode, "FUZZY+PID" artificial intelligent control

Relay output	3A/250VAC 5A/30VDC
SSR voltage output	12VDC/50mA(Used to drive SSR)
Triac no contact output (Built in SSR output)	1A/240VAC(It can directly control the Max 1A AC100~240V electric heating tube, or control the high current load by controlling the AC contactor)
Thyristor zero crossing trigger output	Can trigger TRIAC of 5~500A, a pair of inverse paralleled SCRs or SCR power module.
Linear current output	Analog 0~20mA, 4~20mA. (Output voltage ≥ 10.5V maximum load resistor 500ohm, output precision 0.2%FS)
EMC	±4KV/5KHz according to IEC61000-4-4; 4KV according to IEC61000-4-5
Isolation withstanding voltage	Between power, relay contact or signal terminals ≥ 2300VDC, between isolated electroweak terminals ≥ 600V
Operating Ambient	Temperature: 0~60°C, Humidity ≤ 90%RH

3. Ordering Code Definition



Code	Model category	Code	OUT(Master output)	Code	ALM(Alarm)
FT3419	High-precision type temperature controller/ regulator	N	None	N	None
FT3419P	80-segment program type temperature controller	R	Relay output	R1	1 way relay output
		Q	SSR voltage output	R2	2 way relay output
③		T	TRIAC no contact normally open output (Built in SSR output)	Q1	1 way SSR output
		X	Analog 0-20mA/4-20mA output	Q2	2 way SSR output
		X5	Analog 0-5V/1-5V output	⑤	
		X8	Analog 0-10V/2-10V output	Code	AUX (Auxiliary output)
②		K1	Single-phase thyristor zero crossing trigger output	N	None
		K5	Single-phase thyristor phase shift trigger output , suitable for 200~240VAC power	R1	1 way relay output
		K6	Single-phase thyristor phase shift trigger output , suitable for 340~415VAC power	Q1	1 way SSR output
				T1	TRIAC no contact output
⑦				X	0-20mA/4-20mA output
				V24	24VDC power output
				V12	12VDC power output
⑧				U5	5VDC power output
				⑥	
				Code	COMM(Communication Interface)
		Blank	Screw terminals	N	None
		C	Contact pin(11 pin)	S	RS485 Interface
				D	AC/DC12~24V
				S2	RS232C Interface

4. Brief introduction of terminal and module

Multiple function Input (MIO): Can input signal from 2-wire transmitter 4-20mA signal by installing I4 (current input) module and I4 module can provide 24VDC to transmitter. If a I2 (on-off signal input) module is installed, Can be used as event input.

Main output (OUTP): Commonly used as control output such as on-off control, and "PID+FUZZY" control output. It also can be used as retransmission output of process value (PV) or set point (SV). Installing R modular can realize relay contact output; installing X, X5, X8 module can realize linear voltage, current output; installing Q module can realize SSR voltage output; installing T module can realize TRIAC no contact normally open output; installing K1 module can implement single-phase thyristor zero crossing trigger output; installing K5 and K6 module can implement single-phase thyristor phase shift trigger output.

Alarm (ALM): Installation of R1 module can achieve 1 alarm relay output (AL1), installation of R2 module can achieve 2 alarm relay output (AL1 + AL2).

Auxiliary output (AUX): In a heating/cooling dual output system, module R1, Q1, X can be installed for the cooling control output. It can also be used as an alarm output by installing the R1 module, and it can also be used as power supply for external sensor when equipped with a V24, V12V, V10, U5 voltage output module (load capacity: Max 50mA). The voltage output module can be installed at any output port location.

Communication Interface (COMM): Module S or S2 can be installed in for communicating with computer (Rs485 and RS232C communication interface).

5. Wiring diagram.

●Screw terminal type wiring diagram

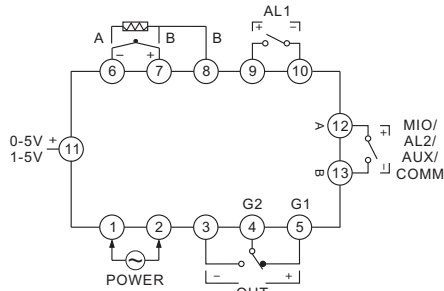

Note: 4~20mA input method is detailed on page 24.

●Contact pin(11 pin)type wiring diagram

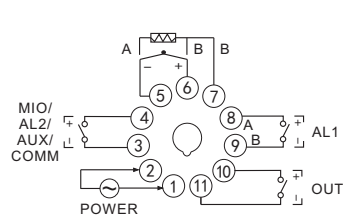

Note: 4~20mA input can be externally connected to 25Ω resistor to become 100~500mV voltage signal, then input from 5th and 6th terminals.

6. Front Panel Description

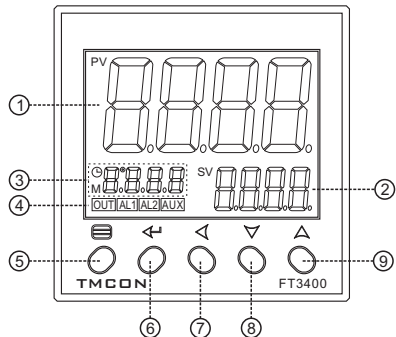

- ① PV first display: display measurement value, parameter name, etc.)
- ② SV second display: display a given value, parameter value, and so on
- ③ MV third display: display temperature unit, program remaining time / program segment number
- ④ Output indicators: OUT, AL1, AL2, AUX indicators
- ⑤ Parameter key: Entry / exit parameter settings
- ⑥ Return key: confirm and switch to the next parameter
- ⑦ Data shift key (Also as manual/automatic switching and program setup key).
- ⑧ Data decrease key (Also as run key)
- ⑨ Data increase key (Also as stop key)

7. Dimensions (in mm) and installation instructions

●Panel size and opening size

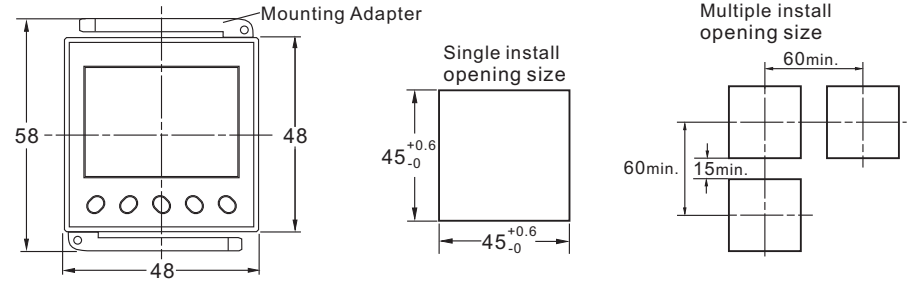

●Screw terminal type (Embedded installation)

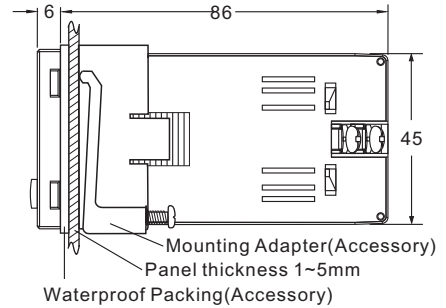
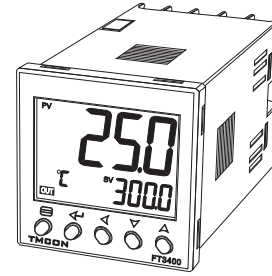

●Contact pin type (11 pin) (Embedded or rail installation) (Relay sockets need to be purchased separately)

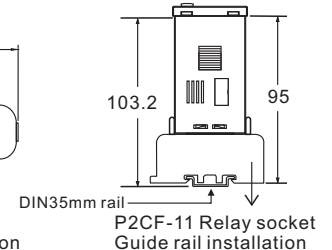
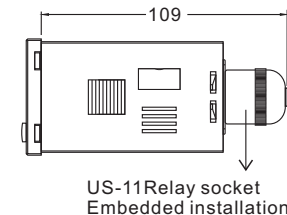
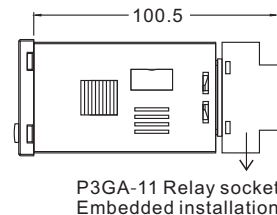
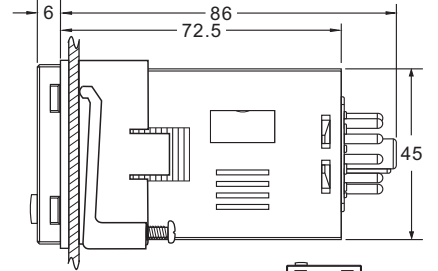
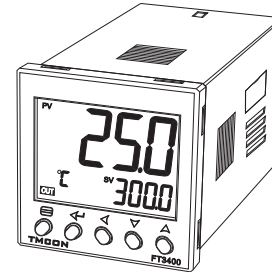

8.Parameter Setting Flow Chart and operation method description

8.1 display status and basic operation flow chart

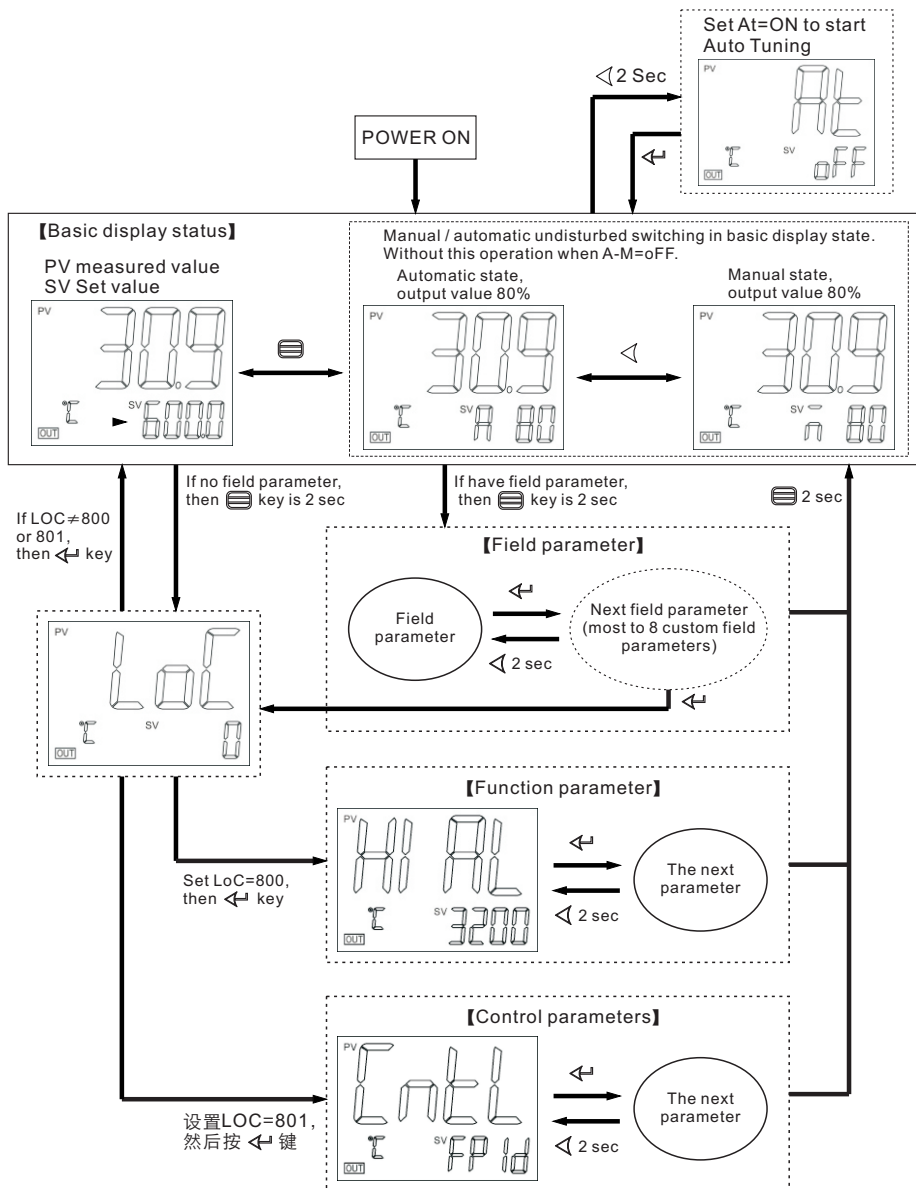

8.2 Program flow chart (FT3419P only)

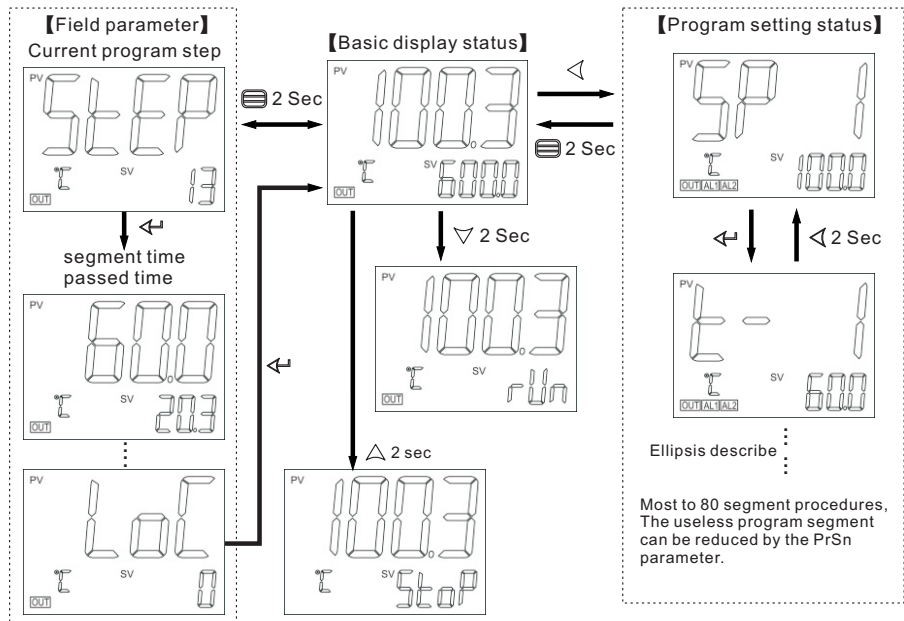

8.3 No.3 display MV

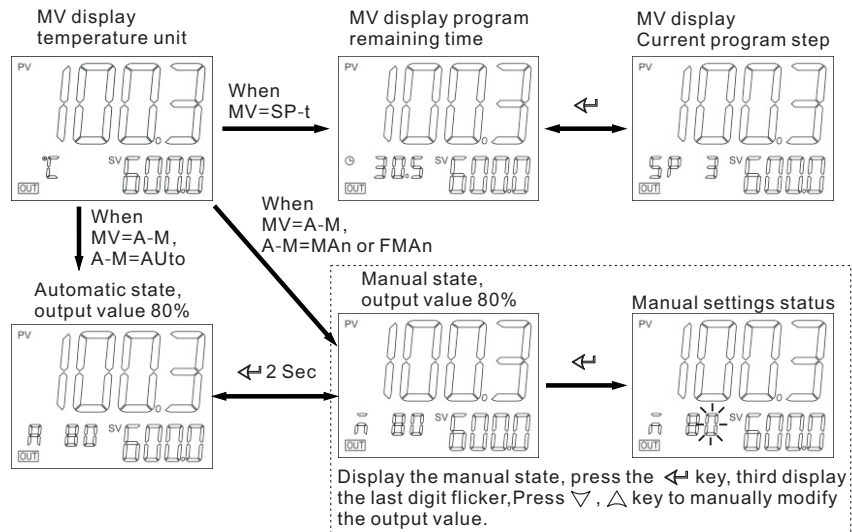

When A-M=FMAAn, For manual state only, no manual / automatic state switch.

8.4 Parameter Setting

In the basic display state, press the **⊞** key and hold for about 2 seconds to enter the field parameter setting state. If you set LOC=800 and press the **←** key, you can enter the function parameter settings. If you set LOC=801 and press the **⊞** key, you can enter the control parameter settings. press the **←**, **▽**, **△**, etc. keys to directly modify the parameter values. press **▽** to decrease the data, press **△** to increase the data, the decimal point that is waiting to modify the value bit will flash (like the cursor)., press and hold, you can quickly increase/decrease the value. You can also press the **←** key to move directly to the value bit you want to modify, and the operation is faster. press the **←** key to save the modified parameter value and display the next parameter. press the **←** key and hold it for more than 2 seconds to return to the previous parameter. press the **⊞** key for hold 2 seconds to return to the basic display state.

8.5 Set Value Setting

FT3419 or FT3419P use fixed-point control mode (when parameter PrSn=0), when the sec display SV displays the basic display state of the given value status (if the second display SV displays the output value, press **⊞** to switch to the given value display). Press **←** to enter the current setpoint status, and then press **←**, **▽**, **△** to directly modify the setpoint.

8.6 Setting up the program:

The controller uses the program control mode (when the PrSn≥1), in the state that the sec display SV displays the given value, press the **←** key to enter the program setting state, first display the current running segment program set value, press **←** Key to display next data, each program is arranged in the order of "program set value - time - program set value".

8.7 Man/Auto mode switch (this function is enabled by the A-M parameter)

In the second display SV display output value state (for example, sec display SV display the given value, double-click **⊞** key to switch to the output value display state), press the **←** key, can be performed to Bumpless switching between AUTO and MAN . If the controller works on Manual mode, its output value can be increased or decreased by pressing **▽** key and **△** key under basic display status.

8.8 Run / Hold (only for FT3419P)

In basic display status, if the program is in stop status ("StoP" is alternately displayed on the lower window), press and hold the **▽** key for about 2 sec until the lower display window displays the "Run" symbol, the instrument then will start the program.

If parameter "PSyS" set F=1, user can hold the **▽** key for about 2 sec, instrument will changes to hold status and lower display window displays the "HoLd" symbol. If parameter "PSyS" set F=0, "Hold" status only can activate by parameter setting (Srun).

At Hold status, the program is still executing, and the process value is controlled same as set, but the timer stop working, and the running time and setpoint remains. At Hold status, press and hold the **▽** key for about 2 seconds until the lower display window displays the "Run" symbol, the instrument will back to run program.

8.9 Stop

Press and hold the **△** key for about 2 seconds in the basic display status, until the lower display window displays the "stoP" symbol, means the stoP operation is executed now, when program stopped, timer will be reset and stop. This operation forces the instrument to stop running, meanwhile, the StEP number will reset to 1, and control output is also stopped.

8.10 MV third display

When the third display is automatic/manual control display (MV=A-M, A-M=AUto or MAN), press **←** for 2 seconds to switch A□□□/M□□□ (automatic/manual control output value) without disturbance. display. when the third display is a fixed manual control display (MV=A-M, A-M=FMAN), then the third display is fixed to M□□□ display. when the third display is M□□□ manual control output value, press **←** key, the last digit of the third display will flash, then press **▽** or **△** key to increase or decrease the manual output value. when the third display is the automatic/manual control display, the automatic/manual control function will no longer be displayed in the second display SV.

When MV=SP-t, the third display will display the current program remaining time/current block number. Press **←** to switch between the current program remaining time/current program segment number.

When MV=oFF, the third display function is closed.

8.11 Auto Tuning

When FUZZY+PID control method is chosen (CntL=FPId), the optimal PID parameters can be obtained by running auto-tuning. So as to achieve precise control without overshoot.

In basal display status, press **←** for 2 seconds, the "At" parameter will appear. Press to change the value of "At" from "oFF" to "on", then press **←** to activate the auto-tuning process. During auto tuning, the instrument executes on-off control. After 2-3 times of on-off action, the instrument will obtain the optimal control parameter value.

If you want to escape from auto tuning status, press and hold the **←** key for about 2 sec until the "At" parameter appear again. Change "At" from "on" to "oFF", press **←** to confirm, then the auto tuning process will be cancelled. (P.S. If parameter "rAte" activate and the heating was running, then will stop the "At" until completed the heat up process.) If the controller was applied on heat/cooling duel output system, PID parameter need separate two group to process auto tuning. When the controller was cooling control from AUX, this time can enable auto tuning to obtain P2, I2, d2.

Note 1: If the setpoint is different, the parameters obtained from auto-tuning are possible different. So you'd better set setpoint to an often-used value or middle value first, and then start auto-tuning. For the ovens with good heat preservation, the setpoint can be set at the highest applicable temperature. Depending on the system, the auto-tuning time can be from several seconds to several hours.

Note 2: Parameter HYS (on-off differential, control hysteresis) has influence on the accuracy of auto-tuning. Generally, smaller value of HYS, will get higher precision of auto tuning result. Too large value of HYS, will made the controller out of control, so, HYS is recommended to be 2.0.

Note 3: FT34** series instrument has the function of self-adaptation. It is able to learn the process while working. he control effect at the first run after auto tuning is probably not perfect, but excellent control result will be obtained after a period of time because of self-adaptation.

9. Parameter list and function

9.1 Field parameter

In the basic display state, press and hold **⊞** key 2 seconds, Enter the field parameters.

Code	Name	Description	Range
5LEP (StEP)	Current execution Program segment (applicable only to FT3419P)	Indicating the currently executing program segment number. Modify this parameter, the program will immediately jump, for example: the current StEP=3, represent the program The runs to the third segment. If you set StEP=8, the program immediately jumps to the eighth segment execution. The settings range for StEP is limited by Prgd and Prg, example: Prgd=8, Prg=2, and so on The program is divided into 8 curves. Now the program performs second curves, Now the program executes the 2 curve, executed by the 11-20 segment program, and the StEP set range is limited to 11-20, and After the instrument is stopped running (StoP), the StEP is automatically set to initial segment 11. Another example: Prgd=0, Prg=0, PrSn=80, then the program does not group, then StEP settings range 1-80, and After the instrument is stopped running (StoP), the StEP is automatically set to initial segment 1.	1~80

<i>PrG</i> (PrG)	Curve group number (applicable only to FT3419P)	Display the currently executing curve group number. When PrGd set curve grouping, you can program multiple curves to deal with different technology to be Seeking, by choosing this parameter to choose to perform the appropriate curve. The PrG setting range is limited by the PrGd parameter: When PrGd = 0, the program is not grouped, PrG can not be set, PrG is fixed at 0. When PrGd = 4, the program is forcibly divided into 4 groups of curves, PrG setting range is 1-4. When PrGd = 8, the program is forcibly divided into 8 groups of curves, PrG setting range is 1-8. When PrGd is forced to group, you can pre program a number of different groups of curves, Then by setting PrG you can quickly and easily choose to execute the appropriate curve. For example: PrGd = 4, PrG = 2, then the program is forced into four groups of curves, the current implementation of the second curve (ie, to implement the procedures in paragraphs 21-40),When the controller implement stop after, StEP is automatically set as the start of the 2nd curve (ie, 21 steps)	0~8
random	Section setting time and already run time(applicable only to FT3419P)	The PV display segment sets the time, and the SV displays the already running time. For example, if the current PV display 30.0/SV shows 10.0, it means that the current running segment setting time is 30.0 minute, and the already running time is 10.0 minute.	
<i>PIdn</i>	PID parameter group number (applicable only to FT3419P)	indicating the currently running PID parameter group number. This parameter cannot be modified and can only be defined programmatically.	0~3
	Custom field parameters	Most to 8 field parameters can be defined by FP1 ~ FP8 (The defined parameters will be transferred from the function parameters or control parameters to the field parameter)	
<i>LoL</i>	Password lock	Set the LOC=800 and then press the <Left> key to enter the function parameters. Set the LOC=801 and then press the <Left> key to enter the control parameters.	0~9999

9.2 Function parameter

In the field parameters, set Loc=800, Then press the <Left> key to enter the function parameters.

Code	Name	Description	Range
<i>HlRL</i>	High limit alarm	Alarm on when PV>HIAL Alarm off when PV<HIAL-AHYS. When the value set to Max. will disable this function Alarm output action can be defined by parameter ALtd.	-999~3200 (-9990~32000)
<i>LoRL</i>	Low limit alarm	Alarm on when PV<LoAL; Alarm off when PV>LoAL+AHYS When the value set to Min. will disable this function	
<i>HdRL</i>	Deviation high alarm	Alarm on when PV-SV>HdAL; Alarm off when PV-SV<HdAL-AHYS When the value set to Max. will disable this function	

<i>LdRL</i>	Deviation low alarm	Alarm on when PV-SV<LdAL; Alarm off when PV-SV>LdAL+AHYS When the value set to Min. will disable this function HdAL and LdAL can also be used as high limit and low limit alarms when needed.(Refer to the description of parameter SScO)	-999~3200 (-9990~32000)																						
<i>LbR</i>	Control loop break off / shorted Alarm	When the instrument control output is equal to oTL or oTH, and the continuous time is greater than LBA setting time, And the PV measurement does not exceed 2 °C change, then determine the control loop failure, the output alarm. The time unit of LBA is second and the alarm port output is defined by ALtd.When LBA = 0, cancel the LBA Alarm function.	0~9999 sec																						
<i>RLtd</i> (ALtd)	Alarm output definition	The number of bits of ALtd represents the output port, ones bits represents AL1, tens bits represents AL2, hundreds bits represents AUX, The value of each bit 0 ~ 9 represents the different alarm function selection, 0 represents no alarm output, 1, 2, 3, 4, 5, 6, 7, 8, 9 respectively represents to HIAL, LoAL, HdAL, LdAL, HIAL+LoAL (Outside the area) ,HdAL+LdAL(Outside the area) ,HIAL+LoAL(within the area) ,HdAL+LdAL(within the area) ,LBA. <div style="display: flex; align-items: center;"> <div style="margin-right: 10px;"> ALtd = <input type="checkbox"/> empty <input type="checkbox"/> AUX <input type="checkbox"/> AL2 <input type="checkbox"/> AL1 </div> <table border="1" style="border-collapse: collapse;"> <thead> <tr> <th>value</th> <th>Representative alarm function parameters</th> </tr> </thead> <tbody> <tr><td>0</td><td>Closing the alarm function</td></tr> <tr><td>1</td><td>HIAL(High limit alarm)</td></tr> <tr><td>2</td><td>LoAL(Low limit alarm)</td></tr> <tr><td>3</td><td>HdAL(Deviation high alarm)</td></tr> <tr><td>4</td><td>LdAL(Deviation low alarm)</td></tr> <tr><td>5</td><td>HIAL+LoAL(Outside the area)</td></tr> <tr><td>6</td><td>HdAL+LdAL(Outside the area)</td></tr> <tr><td>7</td><td>HIAL+LoAL(within the area)</td></tr> <tr><td>8</td><td>HdAL+LdAL(within the area)</td></tr> <tr><td>9</td><td>LBA(Control loop shorted Alarm)</td></tr> </tbody> </table> </div> <p>For example: ALtd = 961, which means that the HIAL upper limit alarm is output by AL1 port, HdAL and LdAL are output by AL2 port can realize outside the area deviation alarm, LBA is output by AUX port.</p>	value	Representative alarm function parameters	0	Closing the alarm function	1	HIAL(High limit alarm)	2	LoAL(Low limit alarm)	3	HdAL(Deviation high alarm)	4	LdAL(Deviation low alarm)	5	HIAL+LoAL(Outside the area)	6	HdAL+LdAL(Outside the area)	7	HIAL+LoAL(within the area)	8	HdAL+LdAL(within the area)	9	LBA(Control loop shorted Alarm)	0~9999
value	Representative alarm function parameters																								
0	Closing the alarm function																								
1	HIAL(High limit alarm)																								
2	LoAL(Low limit alarm)																								
3	HdAL(Deviation high alarm)																								
4	LdAL(Deviation low alarm)																								
5	HIAL+LoAL(Outside the area)																								
6	HdAL+LdAL(Outside the area)																								
7	HIAL+LoAL(within the area)																								
8	HdAL+LdAL(within the area)																								
9	LBA(Control loop shorted Alarm)																								
<i>RHY5</i>	Alarm hysteresis	Avoid frequent alarm on-off action because of the fluctuation of PV.	0~200.0 (0-2000)																						
<i>Rdon</i>	Alarm ON delay	Alarm ON action delay, unit is seconds, When Adon=0, will no alarm ON delay function.	0~999 sec																						
<i>Rdof</i>	Alarm OFF delay	Alarm OFF action delay, unit is seconds, When Adof=0, will no alarm OFF delay function.																							

<i>RdL</i>	Alarm delay definition	0: no alarm delay function. 1:AL1 alarm output has delay. 2:AL2 alarm output has delay. 3:AUX alarm output has delay. 5:AL1, AL2 alarm output has delay. 7:AL1, AL2, AUX alarm output has delay. 4 and 6:empty.	0~7																																																																		
<i>RL</i>	Definition of alarm self lock	When the alarm self-locking takes effect, the alarm output remains self - locking, no matter how the measured value changes.When the measured value does not conform to the alarm condition, the power supply is reopened, and the alarm will be lifted. 0: no alarm self locking function. 1:AL1 alarm has self lock. 2:AL2 alarm has self lock. 3:AUX alarm has self lock. 5:AL1, AL2 alarm has self lock. 7:AL1, AL2, AUXalarm has self lock. 4 and 6:empty.	0~7																																																																		
<i>RL E</i>	Definition of First alarm exemptions	When Power start, if the happen first alarm will be exemption. 0: No First alarm exemptions function. 1: HIAL has First alarm exemptions. 2: LoAL has First alarm exemptions. 3: HdAL has First alarm exemptions. 4: LdAL has First alarm exemptions. 5: HIAL, LoAL has First alarm exemptions. 6: HdAL, LdAL has First alarm exemptions. 7: HIAL, LoAL, HdAL, LdAL has First alarm exemptions.	0~7																																																																		
<i>Int</i> (Int)	Input specification Code	<table border="1"> <thead> <tr> <th>Int</th> <th>Input spec</th> <th>Int</th> <th>Input spec</th> </tr> </thead> <tbody> <tr> <td>0</td> <td>K (-50.0~+1300°C)</td> <td>18</td> <td>J (0~300.00°C)</td> </tr> <tr> <td>1</td> <td>S</td> <td>20</td> <td>Cu50</td> </tr> <tr> <td>2</td> <td>R</td> <td rowspan="3">21</td> <td rowspan="3">Pt100 (-200.0~+600.0 °C)</td> </tr> <tr> <td>3</td> <td>T</td> </tr> <tr> <td>4</td> <td>E</td> </tr> <tr> <td>5</td> <td>J</td> <td>22</td> <td>Pt100 (-100~+300.00 °C)</td> </tr> <tr> <td>6</td> <td>B</td> <td>25</td> <td>0~75mV</td> </tr> <tr> <td>7</td> <td>N</td> <td>26</td> <td>0~80Ω</td> </tr> <tr> <td>8</td> <td>WRe3-WRe25</td> <td>27</td> <td>0~400Ω</td> </tr> <tr> <td>9</td> <td>WRe5-WRe26</td> <td>28</td> <td>0~20mV</td> </tr> <tr> <td rowspan="2">10</td> <td rowspan="2">Special custom input specification</td> <td>29</td> <td>0~100mV</td> </tr> <tr> <td>30</td> <td>0~60mV</td> </tr> <tr> <td rowspan="2">12</td> <td rowspan="2">F2 radiation type pyromter</td> <td>31</td> <td>0~1V</td> </tr> <tr> <td>32</td> <td>0.2~1V</td> </tr> <tr> <td rowspan="3">15</td> <td rowspan="3">Spare</td> <td>33</td> <td>1~5V (4~20mA)</td> </tr> <tr> <td>34</td> <td>0~5V (0~20mA)</td> </tr> <tr> <td>35</td> <td>-20~+20mV</td> </tr> <tr> <td rowspan="2">16</td> <td rowspan="2">Spare</td> <td>36</td> <td>-100~+100mV</td> </tr> <tr> <td>37</td> <td>-5V~+5V</td> </tr> </tbody> </table>	Int	Input spec	Int	Input spec	0	K (-50.0~+1300°C)	18	J (0~300.00°C)	1	S	20	Cu50	2	R	21	Pt100 (-200.0~+600.0 °C)	3	T	4	E	5	J	22	Pt100 (-100~+300.00 °C)	6	B	25	0~75mV	7	N	26	0~80Ω	8	WRe3-WRe25	27	0~400Ω	9	WRe5-WRe26	28	0~20mV	10	Special custom input specification	29	0~100mV	30	0~60mV	12	F2 radiation type pyromter	31	0~1V	32	0.2~1V	15	Spare	33	1~5V (4~20mA)	34	0~5V (0~20mA)	35	-20~+20mV	16	Spare	36	-100~+100mV	37	-5V~+5V	0~37
Int	Input spec	Int	Input spec																																																																		
0	K (-50.0~+1300°C)	18	J (0~300.00°C)																																																																		
1	S	20	Cu50																																																																		
2	R	21	Pt100 (-200.0~+600.0 °C)																																																																		
3	T																																																																				
4	E																																																																				
5	J	22	Pt100 (-100~+300.00 °C)																																																																		
6	B	25	0~75mV																																																																		
7	N	26	0~80Ω																																																																		
8	WRe3-WRe25	27	0~400Ω																																																																		
9	WRe5-WRe26	28	0~20mV																																																																		
10	Special custom input specification	29	0~100mV																																																																		
		30	0~60mV																																																																		
12	F2 radiation type pyromter	31	0~1V																																																																		
		32	0.2~1V																																																																		
15	Spare	33	1~5V (4~20mA)																																																																		
		34	0~5V (0~20mA)																																																																		
		35	-20~+20mV																																																																		
16	Spare	36	-100~+100mV																																																																		
		37	-5V~+5V																																																																		

<i>dP</i>	Display Resolution	Four formats (0/0.0/0.00/0.000) are selectable. Note 1: For thermocouples or RTD input, only 0 or 0.0 is selectable, and the internal resolution is 0.1. When S type thermocouple is used, dP is recommended to be 0. If Inp= 17,18 or 22,resolution will support display 0.0 or 0.00	
<i>lnL</i>	Signal scale low limit	Used to define the lower limit scale value of the linear input signal(Display lower limit value); it is also used to define the lower limit scale of the output signal when the controller is used as a transmission output(CntL=Pvtr or Svtr) .	-999~3200 (-9990~32000)
<i>lnH</i>	Signal scale high limit	Used to define the high limit scale value of the linear input signal(Display high limit value); it is also used to define the high limit scale of the output signal when the controller is used as a transmission output(CntL=Pvtr or Svtr) .	
<i>Sc</i>	Input Shift Adjustment	Sc is used to shift input to compensate the error caused by transducer, input signal, or auto cold junction compensation of thermocouple. PV after compensation=PV before compensation + Sc It is generally set to 0. The incorrect setting will cause measurement inaccurate.	-199~400 (-1990~4000)
<i>lnF</i>	PV input filter	The value of InF will determine the ability of filtering noise. When a large value is set, the measurement input is stabilized but the response speed is slow. Generally, it can be set to 1 to 3. If great interference exists, then you can increase parameter "InF" gradually to make momentary fluctuation of measured value less than 2 to 5. When the instrument is being metrological verified, "InF" s can be set to 0 or 1 to shorten the response time.	0~40
<i>dU</i>	Temperature unit	°C: Centigrade. °F: Fahrenheit degree. Thermocouples and RTDs only	
<i>r5PL</i> (rSPL)	Signal scale low limit for External input SV set value	Use the external signal remote control SV set value function to define the lower limit of the signal scale. Use the position proportional output function to define the lower limit of the valve position feedback signal, This parameter can be set automatically by the valve auto-tuning function.	-999~3200 (-9990~32000)
<i>r5PH</i>	Signal scale high limit for External input SV set value	Use the external signal remote control SV set value function to define the high limit of the signal scale. Use the position proportional output function to define the high limit of the valve position feedback signal, This parameter can be set automatically by the valve auto-tuning function. WARNING: Valve position auto-tuning values Do not modify rSPH and rSPL parameters unless you are a professional.	

<i>RdrS</i> (AdrS)	Communication address	In the same communication line, different instrument should be set to different address.	0~100
<i>bPS</i>	Baud rate	bPS parameter defines the communication baud rate, which can be defined as the range of 1200 ~ 19200bit / s (19.2K). When the meter has no communication function, the AUX port can be used as the PV measurement value transmission output function by the bPS parameter setting, so that the meter has 1 path PID control output and 1 path transmission output: bPS = 3, the AUX port as 0 ~ 20mA PV measured value retransmission output function; bPS = 4, the AUX port as 4 ~ 20mA PV measured value retransmission output function.	0~19.2K
<i>PRrI</i> (PArI)	Communication verification	nonE : No verification odd : Odd number verification EVEN : Even number verification	
<i>CoM</i> (COMM)	Communication protocol	FBUS: instrument communication protocol for FTBUS. MBUS: instrument communication protocol for MODBUS.	
<i>Evt</i> (Evt)	Event input type	When I2 module was installed, the meter have following functions. nonE : Disable event input function. reSt : Run / Stop switching function. Connected in short time, start to running program, keep connect more than 2 sec, program switch to stop. SP1.2 : Switching between setpoint 1 and setpoint 2 when use FT3419 or PrSn=0 at FT3419P. MIO in open status, SV=SP1, when MIO in close status, SV=SP2. Pid2 : Switching 1st PID and 2nd PID. When use as single direction control, MIO in open status, P, I, d and CP was active, when MIO in close status, P2, I2, d2 and CP2 was active.	
<i>SSCo</i>	Advanced System Code	SSCo is used to select advanced function. The value of AF is calculated as below: $AF=A \times 1 + B \times 2 + C \times 4 + D \times 8 + E \times 16 + F \times 32 + G \times 64 + H \times 128$ A=0, HIAL and LoAL work as high and low limit alarms; A=1, HIAL and LoAL will become to deviation high alarm and Deviation low alarm, and the instrument can have two groups of deviation high and low limit alarms. B=0, HdAL and LdAL work as deviation high and low limit alarms; B=1, HdAL and LdAL work as high and low limit alarms, and the instrument can have two groups of high and low limit alarms. C=0, Alarm and control hysteresis work as unilateral hysteresis; C=1, As bilateral hysteresis. D=0, The SV set value is set by the instrument panel operation; D=1, The SV set value is external signal remote control and the external signal is from the 5V input. E=0, The external input SV set value signal is 1-5V;	0~255

		E=1, The external input SV set value signal is 0-5V. F=0, The transmit output is defined scale with InL/InH; F=1, The transmit output is defined scale with rSPL/rSPH. G = 0, normal input mode, G = 1, linear input signal for rooting processing. H=0, Fine control mode, internal control resolution was demonstration's 10 times. When on linear input mode, biggest display value is 3200 units; H=1, Wide range display mode, This mode is selected when the linear input requires a maximum display value greater than 3200.	
<i>SP L</i>	Low limit of SV	Minimum value that SV is allowed to be.	-999~ 3200 (-9990~ 32000)
<i>SP H</i>	Upper limit of SV	Maximum value that SV is allowed to be.	
<i>SP 1</i>	Setpoint 1	For FT3419 meter or FT3419P parameters PrSn=0 or 1, normally Given value SV=SP1.	
<i>SP 2</i>	Setpoint 2	For FT3419 or FT3419P parameters PrSn=0 or 1, When I2 module installed in MIO position, SP1 and SP2 can be switched by an external switch. If the switch is off, SV=SP1; if the switch is on, SV=SP2.	
<i>Pont</i> (Pont)	Program run mode after power restart (applicable only to FT3419P)	Cont : Continue to run the program from the original break point. If STOP STATUS was activated before power cut, then it (the program) will keep stop status after power restart. StoP : Stop the program after power restart run1 : Start to run the program from starting segment unless the instrument was in "stop" state before power cut. dASt : If these have deviation alarm after power resume, then stop the program, otherwise, continue run the program from the original break point. HoLd : Go into HOLD state after power on. If it is in StoP state before power cut, then keep in StoP State after power on.	
<i>PSYS</i>	Program Running mode (applicable only to FT3419P)	The PSYS parameter is used to select the program control function, which is calculated as follows: $PSYS = Ax1 + Bx2 + Cx4 + Dx8 + Ex16 + Fx32$ When A=0, Disenable ready (rdy) function; A=1, Enable ready (rdy) function. B=0, Ramp mode; B=1, Soak mode. C=0, Time unit in Minute, the range is 0.1~3200; C=1, Time unit in Hour, the range is 0.1~3200. D=0, Disable PV start up function; D=1, Enable PV start up function. E=0, When work as program generator, upper windows display PV; E=1, When work as program generator, upper windows display the current step. F = 0, the standard operating mode; F = 1, the program running RUN operation will enter the pause (HOLD) state.	0~255

$PrGd$ (PrGd)	Program grouping definition (applicable only to FT3419P)	When PrGd=0, no grouping. When the PrGd=4 is divided into 4 curves, each group has 20 segments program , SP1-20 segment procedures for the 1 curve group, SP21-40 segment procedures for the 2 curve group, SP41-60 segment procedures for the 3 curve group, SP61-80 segment procedures for the 4 curve group. When the PrGd=8 is divided into 8 curves, each group has 10 segments program. SP1-10 segment procedures for the 1 curve group, SP11-20 segment procedures for the 2 curve group, SP21-30 segment procedures for the 3 curve group, SP31-40 segment procedures for the 4 curve group, SP41-50 segment procedures for the 5 curve group, SP51-60 segment procedures for the 6 curve group, SP61-70 segment procedures for the 7 curve group, SP71-80 segment procedures for the 8 curve group.	0~8																																								
$PrSn$ (PrSn)	No. of Program step (applicable only to FT3419P)	When PrGd=0, PrSn to define the number of program in use. PrSn= 0: disable the program running mode, then FT3419P will same as FT3419, meanwhile, can set the parameter "rAte" to limit the ramp time. Prn=1~80: FT3419P working as normal programmable controller. When PrGd=4 or 8, the PrSn is fixed to 80.	0~80																																								
$LoC2$	Parameter Lock	Parameter was protected by LoC2 (Parameter LOCK) to prevent setting error. The function was shown as below: √ : allow to modify data or execute X : not allow to modify data or execute Run, Stop, Hold. and Program Time & Temp. function just for FT3419P only																																									
		<table border="1"> <thead> <tr> <th>LOC</th> <th>Field parameters</th> <th>SV</th> <th>Program Step Time & Temp</th> <th>Shortcut keys for run, stop, or hold</th> </tr> </thead> <tbody> <tr> <td>oFF</td> <td>√</td> <td>√</td> <td>√</td> <td>√</td> </tr> <tr> <td>LCK1</td> <td>√</td> <td>√</td> <td>√</td> <td>X</td> </tr> <tr> <td>LCK2</td> <td>√</td> <td>X</td> <td>X</td> <td>√</td> </tr> <tr> <td>LCK3</td> <td>√</td> <td>X</td> <td>X</td> <td>X</td> </tr> <tr> <td>LCK4</td> <td>X</td> <td>√</td> <td>√</td> <td>√</td> </tr> <tr> <td>LCK5</td> <td>X</td> <td>√</td> <td>√</td> <td>X</td> </tr> <tr> <td>LCK6</td> <td>X</td> <td>X</td> <td>X</td> <td>X</td> </tr> </tbody> </table>	LOC	Field parameters	SV	Program Step Time & Temp	Shortcut keys for run, stop, or hold	oFF	√	√	√	√	LCK1	√	√	√	X	LCK2	√	X	X	√	LCK3	√	X	X	X	LCK4	X	√	√	√	LCK5	X	√	√	X	LCK6	X	X	X	X	
LOC	Field parameters	SV	Program Step Time & Temp	Shortcut keys for run, stop, or hold																																							
oFF	√	√	√	√																																							
LCK1	√	√	√	X																																							
LCK2	√	X	X	√																																							
LCK3	√	X	X	X																																							
LCK4	X	√	√	√																																							
LCK5	X	√	√	X																																							
LCK6	X	X	X	X																																							
$\bar{n}u$ (Mv)	MV third display	OFF: off MV function, MV only as a temperature unit display. A-M: automatic / manual control will be displayed by MV. SP-t: MV will display the current program remaining time / block number.																																									
$FP1$ \sim $FP8$	Field parameter definition	You can select 8 parameters in the function parameters or control parameters as field parameters. If there are no or less than 8 field parameters, the FP* value can be set to nonE.																																									

9.3 Control parameter

In the field parameters, set Loc=801, Then press the \leftarrow key to enter the control parameters.

$CntL$ (CntL)	Control mode	onoF: on-off control. For situation not requiring high precision FPId: advanced artificial intelligence FUZZY+PID control(Recommended use). PVtr: The controller is used as a measurement display or digital display transmitter. the SV will display the temperature unit. when the linear signal is input, the SV will not be displayed, and can directly use the PV value as the output value. when the OUT is installed with a 4-20 mA module, the meter can be used as a transmitter. SVtr: Directly use the SV value as the output value. When OUT installs the 4-20mA module, the meter can be used as the program given generator.	
HYS	Control Hysteresis	HYS is used for on-off control to avoid frequent on-off action of relay. For a reverse acting (heating) system, when PV > SV, output turns off; when PV<SV-HYS, output turns on. For a direct acting (cooling) system, when PV<SV, output turns off; when PV>SV+HYS, output turns on.	0~200.0 (0-2000)
$orEv$ (orEv)	Acting method (Control direction)	onr: Reverse acting. Increase in measured variable causes a decrease in the output, such as heating control. ond: Direct acting. Increase in measured variable causes an increase in the output, such as refrigerating control.	
$dEzo$ (dEzo)	dead zone	dEzo is only suitable for heating-cooling two-way adjustment. The dead zone is set around the SV set point. When the set value is positive, it becomes a static zone (no action zone). When the set value is negative, it becomes an overshoot zone. The decimal point position is defined by the dP parameter.	-1999~ 9999
$Srun$ (Srun)	Running Status	Run: Runs the control state and allows the run or stop operation from the panel keys. StoP: Stops the state and allows the run or stop operation from the panel keys. HoLd: When the controller is FT3419 or FT3419P and the PrSn=0, this state is the same as the running state, but it is prohibited to perform the run or stop operation from the panel keys. When the controller is FT3419P and the parameter PrSn>0 program control, the meter keeps constant temperature controlling output in this state, but pauses the timing, and the second display SV flashes to display "HoLd", which can be run or stop by the panel keys operation to release the hold.	
$A-\bar{n}$ (A-M)	Auto / manual Control selection	OFF: no automatic / manual switching control function, the instrument for the automatic control of the state. Man: manually control the state, manually adjust the output of oUT, and can switch to automatic control. Auto: automatic control state, oUT output determined by the CntL decision after the decision, and can switch to manual control. FMA: fixed manual control state, this mode prohibits the	

		direct operation from the front panel keys Change to automatic state.	
Rt (At)	Auto tuning	oFF: Auto tuning function was off. on:Start the PID parameter auto-tuning function,and the auto-tuning finish will automatically return to oFF. FoFF : Auto tuning function was off, and cannot activate again by pressing key from panel .	
P	Proportional band (No.1 PID parameter)	Proportional band in FPID control. Instead of percentage of the measurement range, the unit is the same as PV. Generally, optimal P, I, D and CP can obtained by auto tuning. They can also be manually inputted if you already know the correct values.	1~3200 (32000)
I	Time of integral (No.1 PID parameter)	Integration time in FPID control, the unit is second, and the integral action is canceled when I=0.	1~9999 sec
d	Time of differential (No.1 PID parameter)	Differential time in FPID control,the unit is 0.1 seconds, and the differential action is cancelled when d=0.	0~3200 sec
CP	Control period (No.1 PID parameter)	Small value can improve control accuracy. For SSR, thyristor or linear current output, it is generally 0.5 to 3 seconds. For Relay output or in a heating/refrigerating dual output control system, generally 15 to 40 seconds, because small value will cause the frequent on-off action of mechanical switch or frequent heating/refrigerating switch, and shorten its service life. CP is recommended to be 1/5 – 1/10 of derivative time. (It should be integer times of 0.5 second) When the parameter OUt or Aut = rELy, CP will be limited to more than 3 seconds. Auto tuning will automatically set CP to suitable value considering both control precision and mechanical switch longevity. When the parameter CntL = onof, CP will be used as timer to make delay time to avoid the power restart in short period. It suit for compressor protection. If the output for the control valve, recommended CP=3~15 seconds, taking into account the response speed and avoid the valveFrequent action.	0.2~ 300.0
P2	Proportional band 2 (No.2 PID parameter)	When the instrument uses the heating / cooling dual output adjustment, it is used as a cold output proportional band. When FT3419P can be used as the second group of PID proportional band.	1~3200 (32000)
I2	Time of integral 2 (No.2 PID parameter)	When the instrument uses the heating / cooling dual output adjustment, it is used as a cold output time of integral. When FT3419P can be used as the second group of PID time of integral.	1~9999 sec
d2	Time of differential 2 (No.2 PID parameter)	When the instrument uses the heating / cooling dual output adjustment, it is used as a cold output time of differential.	0~3200 sec

	parameter)	When FT3419P can be used as the second group of PID time of differential.	
CP2	Control period 2 (No.2 PID parameter)	When the instrument uses the heating / cooling dual output adjustment, it is used as a cold output control period. When FT3419P can be used as the second group of PID control period.	0.2~ 300.0
P3	Proportional band 3 (No.3 PID parameter)	Applicable only to FT3419P	1~3200 (32000)
I3	Time of integral 3 (No.3 PID parameter)	Applicable only to FT3419P	1~9999 sec
d3	Time of differential 3 (No.3 PID parameter)	Applicable only to FT3419P	0~3200 sec
CP3	Control period 3 (No.3 PID parameter)	Applicable only to FT3419P	0.2~ 300.0
oUt (oUt)	Main output type	SSr: SSr drive voltage output or TRIAC no contact normally output or thyristor zero crossing trigger signal. rELy: Relay contact output 0-20: 0~20mA linear current output(Also suitable for 0-5V or 0-10V output). 4-20: 4~20mA linear current output(Also suitable for 1-5V or 2-10V output). PHA: Single-phase phase-shift output. PHA is only for 50Hz power supply, and don't support bidirectional control system. NFEd: no feedback signal position proportional output, direct control valve motor positive / reverse, Valve travel time defined by Vrtt parameters. FEd: position feedback signal output, the valve travel time should be more than 10 seconds, Feedback signal input from the 0~5V/1~5V input. Note: The External input SV set value function can no longer be used in this output mode. FEAt: auto-tuning valve position, the instrument will first close the valve will be feedback signal recorded in the rSPL parameters, and then fully open the valve memory valve feedback signal in the rSPH parameters, after completion Automatically returns the FEd control mode.	
AUt (Aut)	Auxiliary output type (as a refrigeration output)	When AUX is used as the auxiliary cooling output in heating / cooling bidirectional regulation, the output type of AUX is defined. SSr: Output SSr drive voltage or thyristor zero crossing trigger signal. rELy: Relay contact output 0-20: 0~20mA linear current output. 4-20: 4~20mA linear current output.	

αtL (otL)	Output low limit	0~100%: otL is the minimum output of OUT in single directional control system. -1~-110%: The instrument works for a bidirectional system, and has heating/refrigerating dual output. OUT (main output) works for heating, and AUX (Auxiliary output) works for refrigerating. In a bidirectional system, otL for define the limitation of maximum cooling output. So, when the otL= -100%, means no limitation on cooling output. If set otL=-110%, it can made current output excess 10% on maximum output. When the output type is SSR output or relay output, maximum of cooling output should not set more than 100%	-110~+110%
αtH (otH)	Output upper limit	Limit the maximum output value of the main output oUt, the setting range is 0~110%. When SSR or relay output, the maximum output limit should not be greater than 100%. 110% can make the current output such as (4~20mA) the maximum range exceeds 100%. Suitable for special occasions. When the measured value PV is less than otEr, otH limits the maximum output value of the main output(oUt), and when PV is greater than otEr, the system correction output upper limit is 100%; In the non-feedback position proportional output (when oUt = nFEd), if otH is less than 100, the Controller Auto Tuning the valve position at power-on. If otH = 100, the Controller Auto Tuning the valve position when the output is 0% and 100% , Can shorten the power on time. otH setting must be greater than otL.	0~110 %
$\nu r t t$ (Vr tt)	Valve travel time	Defines the travel time of the valve rotation when the meter is the position proportional control output, If there is a valve feedback signal, the instrument will automatically select the valve control signal according to Vr tt's setting. Of the hysteresis, the shorter the travel time, the greater the hysteresis, the valve positioning accuracy will be reduced. When using a valveless feedback signal mode or valve feedback signal to generate an overrange malfunction, The instrument will be based on Vr tt travel time comparison output to determine the valve motor action time.	10~300
$\alpha t E r$ (otEr)	Work range of OPH	otEr can implement the segmentation output power limit. When PV<otEr, the upper limit of OUTP is OPH; when PV>otEr, the upper limit of OUTP is 100%. For example, to avoid that the temperature raises too quickly, under 150°C, a heater can work only under 30% of output power, then we can set otEr=150.0 (°C), OtH=30 (%), then, when the temperature is lower than 150 °C, the upper limit of the output power is 30%, 150°C or more, and the upper limit of the output power is 100%.	-999~3200°C or Linear unit

$rAtE$ (rAtE)	Heating rate limit (applicable only to FT3419P)	If rAtE is set to valid, when the program starts, if PV < SV, the temperature will first rise to the first set value according to the heating rate limit defined by rAtE. In the temperature increase rate limit state, "PV" character flashes. For slope mode, rAtE is only valid for the first paragraph program, while in platform mode, rAtE is valid for any paragraph program.	0-3200 °C/min
------------------	--	---	---------------

10. Additional Remarks of Special Functions

10.1 position proportional output

FT3419/FT3419P can directly drive the motor to control the valve, and supports two modes: valve position feedback signal and valve position feedback signal. When no feedback position ratio is output (oUt=nFEd), If otH is less than 100, the instrument will auto tuning the valve position when power on, that is, automatically close the valve when power on, and the time is valve stroke time. Meanwhile, the otH parameter can limit the maximum valve opening under the condition that the measured value PV is less than the parameter otEr. If the otH = 100 is set, the instrument will auto tuning the valve position when the output is 0% and 100%, and will not auto tuning the valve position when power on to shorten the start-up time.

When the proportional output of the feedback position is set to oUt = FEAT, the instrument automatically closes the valve first, then opens the valve completely, and then measures the feedback signal to set the valve position and save it. After the valve position is auto tuning, the instrument automatically sets the parameter oUt to FED for normal control. If the feedback signal exceeds 2% of the measurement range, The instrument will decided there the feedback signal is abnormal and automatically control it in a valveless feedback mode, and display "FEr" in the lower display window to indicate an error. The feedback signal can be 1K resistor (Need to be equipped with U5 module) or 0~5V/1~5V signal (Parallel 250 resistance can be converted to 0~20mA/4~20mA).

Position proportional output (valve feedback signal is 1K resistor) wiring diagram of direct drive valve:

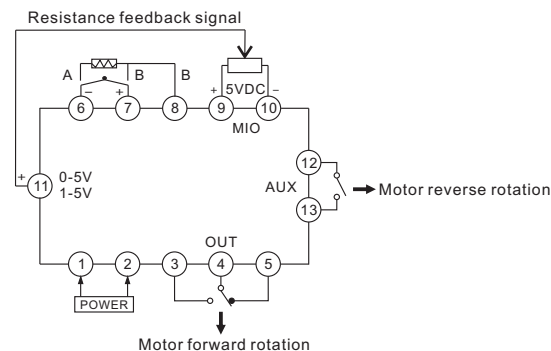

When the valve position feedback signal is a potentiometer, install a non-isolated 5V power distribution output module U5 to convert the resistance signal into a voltage signal (as the picture shows).

When the valve position feedback signal is 0-5V or 1-5V (the current signal needs to be converted into voltage by the resistor), the direct 11+ and 6- terminals can be used.

10.2 Manual auto-tuning (only for valve position control and where automatic auto-tuning is not allowed)

In the system difficult to control or in the applications in which some executive bodies such as control valve is used and therefore outputs are not allowed to be greatly changed, traditional auto tuning is not suitable. FT3419/3419P instruments have manual auto tuning mode. To do this, switch the instrument to manual mode. After manual control is basically stable, start up auto tuning at manual mode, and the output will be restricted in the range between +10% and -10% of the current manual output. This function can avoid great change of valve and improve the precise of auto-tuning.

Note: before manual auto-tuning, the manual output value should be limited in the range of 10% - 90%, otherwise optimal parameters can be obtained.

10.3 Single-phase phase-shift trigger output

When OUT is set to PHA, installing a K5 or K6 module in OUT slot can single-phase phase-shift trigger a TRIAC or 2 inverse parallel SCRs. It can continuously adjust heating power by control the conduction angle of thyristor. With non-linear power adjustment according to the characters of sine wave, it can get ideal control. The trigger adopts self-synchronizing technology, so it can also work even when the power supplies of the instrument and the heater are different. Phase-shift trigger has high interference to the electric power, so user should pay attention to the anti-interference ability of other machines in the system. Now the K5 or K6 module can be only used in 50Hz power supply.

10.4 dead zone

When set to oTL is negative (-1-110%), the instrument becomes a bidirectional adjustment system, with heating-cooling bidirectional adjustment output function, with two independent PID adjustment function, the main output oUt for heating, auxiliary output AUX for cooling.

dEzO is suitable for heating-cooling two-way adjustment system. The dead zone is set around the SV set point.

When the set value is positive, it becomes a static zone (no action zone). When the set value is negative, it becomes an overshoot zone.

As shown in the figure:

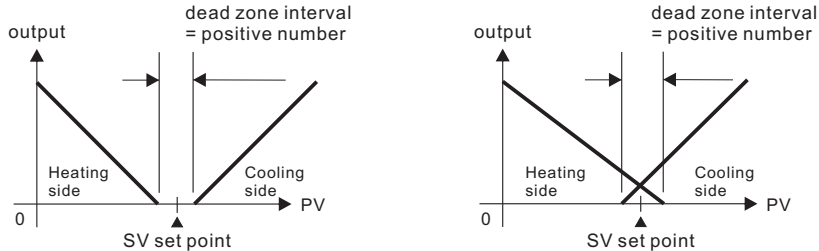

10.5 Temperature re-transmitter / Program generator / Manual current output

Besides FUZZY+PID, and on-off control, if the output is defined as current output, the instrument can also retransmit PV (process value) or SV (setpoint) into linear current and output from OUTport. The precision of current output is 0.2%FS. Base on that ability, FT3419 can become temperature re-transmitter and FT3419P can become program generator. The corresponding parameters are set as below:

When CntL=Pvtr, PV is retransmitted to linear current, the instrument works as temperature re-transmitter.

When CntL=Svtr, SV is transmitted and outputted, and the instrument works as manual current output controller(FT3419) or program generator(FT3419P).

Out is used to choose output type, generally 4~20mA or 0~20mA output.

Parameter Int, InL, InH, and Sc are used for selecting input specification, setting low limit or high limit of PV and adjusting input.

For example, in order to retransmit temperature read from K thermocouple, range 0~400 °C, to current 4~20mA, the parameters are set as below: Int=0, InL=0.0, InH=400.0, OUT=4~20, and X linear current module is installed in OUT slot. When the temperature is less than or equal to 0°C, the output is 4mA. When the temperature equals to 400°C, the output is 20mA.

10.6 External signal remote control SV set value

When an external signal is allowed to remote control SV set value (see the SSCo parameter description), the meter can input a 1-5V voltage signal from the 5V terminal of its terminal to indicate the SV value. The scale of the external signal can be determined by the In-L/In-H or rSPL/rSPH parameters. If the voltage signal of the external signal is less than 1V, the external signal is automatically canceled to set the SV value, and the internal set the SV value is used instead. When using the external signal remote control SV set value function, the meter measurement input cannot be used with 1-5V/0-5V, which has no effect on thermocouple, RTD and mV voltage input. If the measurement input is 0-10 mA or 4-20 mA, the main input of the meter can be set to 0-1V or 0.2V-1V, then external 100 ohm or 50 ohm resistor. The external signal remote control SV set value function can the instrument to form a ratio or cascade adjustment system to perform complex adjustment functions.

10.7 Alarm delay diagram

Schematic diagram of alarm delay output:

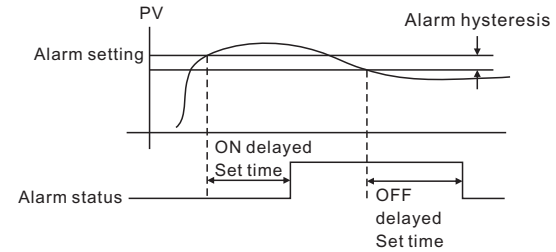

The alarm ON delay also takes effect when the power is turned on. When the interval of the alarm ON is the ON delay setting, the alarm output will not turn ON. Similarly, when the alarm OFF interval is below the OFF delay setting, the alarm output will not be turned OFF.

During the ON delay, when the alarm is turned ON → OFF → ON, the measurement is restarted from the time when the alarm is last turned ON. Similarly, during the OFF delay, when the alarm is turned OFF → ON → OFF, the measurement is restarted from the time when the alarm is finally turned OFF.

10.8 Alarm self-locking

If the alarm latch function is set to active, when the alarm output is ON, it will remain in the ON state regardless of the temperature change.

Alarm unlocking method: Release after power off (after the controller is powered on again, if the measured value does not meet the current alarm condition, the alarm will be turned off).

This feature is often used as an over temperature protection feature. It can be used to force the main power off when an over temperature occurs, until the operator troubleshoots.

10.9 First alarm exemptions

Sometimes the fault alarm may occur at the beginning of power on. In a heating system, at the beginning of power on, its temperature is much lower than the set point. If low limit and deviation low limit are set and the alarm conditions are satisfied, the instrument should alarm, but there is no problem in the system. Contrarily, in a refrigerating system, the unnecessary high limit or deviation high limit alarm may occur at the beginning of power on. Therefore, Ft34** instruments offer the function of alarm blocking at the beginning of power on. When ALE is set to 1~7, the corresponding low or high alarms are blocked until the alarm condition first

clears. If the alarm condition is satisfied again, the alarm will work.

11.10 LBA Control loop break off / shorted Alarm

When the control output becomes oH or oL. At each interval LBA set time as a unit to monitor of changes in the PV value. According to the amount of change to determine whether there is any abnormal control circuit. The time unit of LBA is second and by AL1 alarm. The following conditions for the alarm status:

① When orEV is onr Reverse action: When the control output of the instrument continues to be oH, the increase of the measured value (PV) within the setting time of LBA is less than the change of LBA judgment (2°C).

When orEV is ond is positive: When the instrument control output continues to oH, the measured value (PV) decreases less than LBA judgment range (2°C) within the setting time of LBA.

② orEV is onr Inverse operation: When the instrument control output continues for oL, the measured value (PV) decreases less than the LBA judgment range (2°C) within the setting time of LBA.

When orEV is ond is in positive operation: When the instrument control output continues to oL, the measured value (PV) rises less than LBA judgment range (2°C) within the setting time of LBA.

11.11 Fine Control

Fine control means that the resolution of PID operation is 10 times higher than the display resolution. For example, the temperature signal of the instrument is displayed as 1°C , but the internal PID is still calculated and controlled according to the resolution of 0.1°C , which can achieve much higher control precision than the display resolution.

In previous versions of the FT series, only the temperature signal was in fine control mode, when the new version is linear input, as long as the displayed value range is less than 3000 words (most applications in industrial applications do not exceed 3000 words), using default fine mode control to obtain higher control precision and more stable output, and when it is necessary to display a value range greater than 3000, SScO.H=1 can be set.

11.12 Communication function

If the COMM port of the meter is configured with an S type RS485 communication interface module. It can realizes multi-machine connection with the computer, and can realize various operations and functions of the instrument through the computer. For computers without RS485 interface, an RS232C/RS485 converter or USB/RS485 converter can be added. Every communication port of a computer can connect up to 60 FT3400 instruments, or 80 FT3400 instruments if a repeater is installed. A computer with 2 communication ports can connect up to 160 instruments. Please note that every instrument connecting to the same communication line should be set to a unique communication address. If the number of instrument are enough, 2 or more computers can be used and a local network can be set up.

The instrument adopts the international MODBUS-RTU communication protocol and the Independence open FTBUS communication protocol. There are a variety of configuration software to support FT3400 instrument communication. To obtain a communication agreement, you can request it free from the meter salesperson.

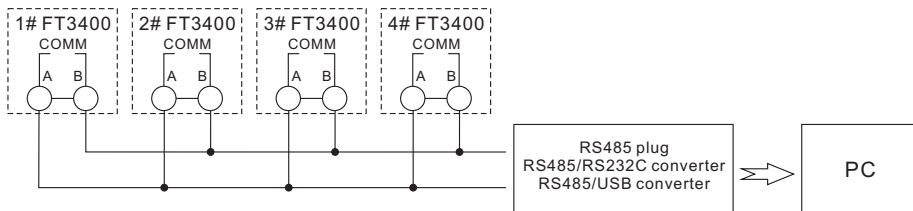

11. Partial application wiring method

11.1 The wiring method of the input signal

<p>● Thermocouple Input</p>	<p>● RTDs Input</p>
<p>● Analog linear voltage input</p>	<p>● Analog linear current input</p>
<p>● MIO port input linear current</p>	
<p>● MIO port event input</p> <p>If the I2 module is installed on the MIO port, a switch can be connected externally to perform the control function. When the parameter Et=ruSt is set, press the button to perform the run operation, when press the button for 2 seconds or more to execute the stop operation. For the FT3419 type meter (or FT3419P type instrument parameter PrSn=0) and the parameter EVt=SP1.2, it can be used to switch two different given points SP1/SP2.</p>	
<p>● Choosing thermocouple cold junction compensation mode based on wire connection</p> <p>(1) Internal automatic compensation mode (Compensating wire shall be directly connected to the connection terminals)</p> <p>(2) Externally connected to copper resistor automatic compensation mode (Thermocouple cold end terminal box had better keep away from heat sources)</p> <p>When using thermocouple as the input, cold junction should be applied for temperature compensation based on the thermocouple temperature measuring principles. All instrument can automatically compensate cold junction referencing the temperature around the wiring terminals. Due to measuring components' errors, instrument's inherent heating and other heat sources nearby, the deviation of automatic compensation modes is comparatively large.</p>	

for which the worst may exceed 2°C. So if higher accuracy is required, an external junction box can be used. Put Cu50 copper resistor (to be purchased separately) and thermocouple cold junction together, and keep away from the heat sources, thus the measuring in conformity caused by compensation may be less than 0.3°C. Because the inherent errors of Cu50 copper resistor may cause certain errors at room temperature, it can be modified with "Sc" parameter. Change the externally connected copper resistor into precision fixed resistance, which may achieve constant temperature bath compensation. For instance, connect it to constant 60Ω resistor, check the reference table of Cu50 and find the compensation temperature of 46.6°C. At this moment, put the thermocouple cold junction into the constant temperature bath for accurate compensation at the temperature of 46.6°C. its compensation accuracy will be better than that of copper resistor. If the externally connected resistance is changed into short circuit, ice-point compensation may be achieved. At this moment, it is required to place the thermocouple cold junction (the joints of the thermocouple or compensation wires and conventional wires) into the ice-water mixture (0°C), its compensation accuracy may reach above 0.1°C.

11.2 Main control output wiring method

● Relay output (OUT port installs R module)

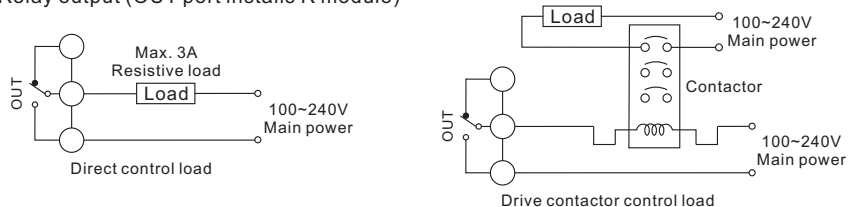

● Thyristor No contact switch output (built-in SSR output)(OUT port installs T module)

T are new types of no contact switch module which apply the advanced technology of "burn proof" and zero crossing conduction. It can replace the relay contact switch. Compared to the relay contact output module, T have longer life and lower interference. They can be largely lower the interference spark of the equipment, and greatly improve the stability and reliability of the system. It can directly control the resistive load below 1A/240V (for example, it can directly control the maximum 250W heating tube), and above 1A can control the high current load by driving the AC contactor. The drive element of the contactless switch is a thyristor, so it is only suitable for controlling AC power of 100~240VAC specifications, but not for controlling DC power.

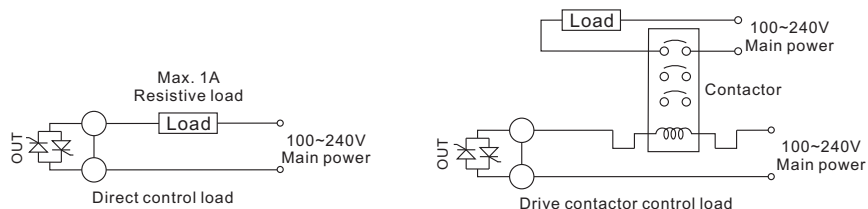

● 12V pulse voltage output drive SSR (OUT port installed Q module)

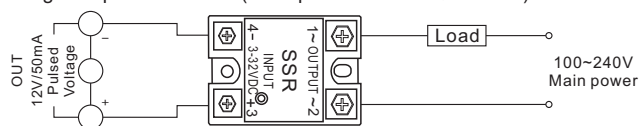

● Thyristor trigger output Wiring diagram

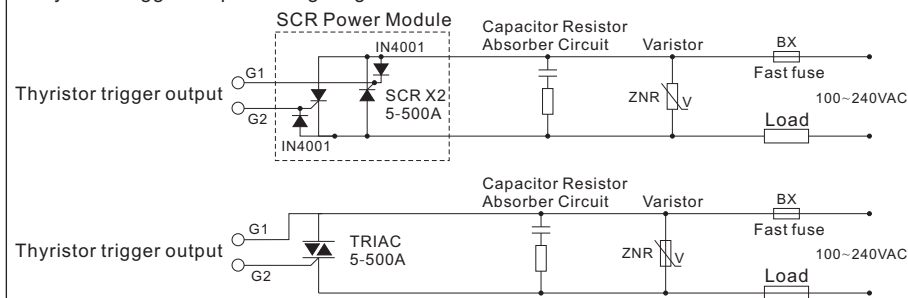

Note 1: According to the voltage and current of load, choose suitable varistor to protect the thyristor. Capacitor resistor absorber is needed for inductance load or phase-shift trigger output.

Note 2: SCR power module is recommended. A power module includes two SCRs, is similar to the above dashed square.

Note 3: Phase-shift trigger module K5 only supports 200~240VAC power, and K6 supports 340~415VAC.

● Linear current and voltage output (OUT port installed X, X5, X8 modules)

Can trigger: SCR power regulator, thyristor phase shift trigger module, PLC, inverter, transmitter, valve actuator, etc.



The following figure uses the 4-20mA output to trigger the SCR to achieve power regulation output:

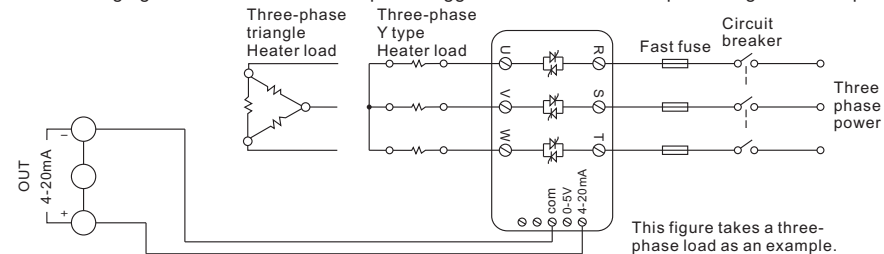

12. Input fault indication

When the display window PV alternately displays the "orAL" character, it indicates that the input of the measurement signal is abnormal or out of range; please check whether the Int parameter setting is consistent with the input sensor signal type. If it is determined to be consistent, please check if there is any problem with the sensor or wiring.

If you purchased is FT3419P, please continue to read the FT3419P additional instructions

13. Further description for the operation of FT3419P series instrument

FT3419P program type temperature controller is used in the application where the setpoint should be changed automatically with the time. It provides 50 segments program control which can be set in any slope and the function of jump, run, hold and stop can also be set in the program. Measurement startup function, preparation function and power-cut/power-resume event handling modes also provided.

13.1 Concepts and functions Program

StEP:

The No. of the program Step can be defined from 1 to 50, and the current Step is the program Step being executing.

StEP time:

Total run time of the program step. The unit is minute and the available value range from 1 to 9999.

Running time:

The Time of current Step has run. As the running time reaches the Step time, the program will jump to the next Step automatically.

Jump:

The program can jump to any other steps in the range of 1 to 50 automatically as you programmed in the program Step, and realize cycle control.

Run/Hold:

When program is in the running status, timer works, and set point value changes according to the preset curve. When program is in the holding status, timer stops, and set point remains to make temperature hold also. The holding operation can be programmed into the program step.

Stop:

When the stop operation is activated, the program will stop, running time will be clear, event output switch will reset and the output control will stop output. If run operation is activated when instrument is in the stop status, the program will start-up and run again from the set step no. The stop function can be programmed into the program Step. The stop operation can also be performed manually at any time. (After stop operation is done, the step no. will be set to initial segment, but user can modify it again). If the program ran the last step of "PrSn", program will stop automatically.

Power cut/resume event handling:

There are 5 events handling method selectable for power resume after power cut off. Please refer to parameter Pont .

PV startup and PV preparation function (rdy function) :

At the beginning of starting a program, resuming a program after power cut or continuing to run a program after it is just modified, the PV (process value) are often quite different from the set point. PV startup function and PV preparation function can make PV and set point consistent, and avoid unexpected result. When PV startup function enabled, the instrument will adjust the running time automatically to make the expected set point is the same as the current PV.

For example, the program is set that the temperature will be raised from 25°C to 625°C in 600 minutes. But the current PV is 100°C, then the instrument will automatically to run this program start from 75 minutes, that mean changed the temperature raised from 100°C to 625°C in 525 minutes (600-75) min.

At the above situation(PV=100, SV=25, first step SV), when PV preparation function is enable, the alarm function will be blocked at that time, and PV will be adjusted to approach SV until the deviation alarm condition is released (PV is between SV-LdAL and SV+HdAL). After deviation alarm was off, the controller starts to run the program again. Preparation function (rdy Function) is helpful to keep the integrity of the program, but it will prolong the program time because the start of the program is postponed. PV startup function is prior to PV preparation function. If both function are enabled, the system apply PV startup first, if PV startup function works, PV preparation function will not be activated.

Curve fitting:

Curve fitting is adopted as a kind of control technology for FT3419P series instrument. As controlled process often has lag time in system response, by the way of curve fitting the instrument will smooth the turning point of the linear heating-up, cooling-down and constant temperature curves automatically. The degree of the smooth is relevant with the system's lag time $t(t=d+CP)$; the longer of the lag time, the curve will more smooth. On the opposite the smooth function will be weaker. Generally the shorter of the process lag time (such as temperature inertia), the better of the program control on effect. By the way of the curve fitting to deal with the program curves, will avoid overshoot. Note: The characteristic of the curve fitting will force the program control to generate fixed negative deviation during the linear heating-up and fixed positive deviation during the linear cooling-down, the deviation is direct proportional to the lag time and the speed of heating-up (cooling-down). This phenomenon is normal.

13.2 Programming and operation (For FT3419P only)

13.2.1 Ramp Mode(PSYS : B=0)

Programming of instrument has uniform format of temperature-time-temperature, which means temperature "A"(SP 1), passed Time "A"(t01), then reached Temperature "B"(SP 2). The unit of temperature set is °C and the unit of time set is minute. The following example includes 5 steps, which is linear temperature heating up, constant temperature, linear temperature cooling down, jump cycling, ready, Hold. For example:

- StEP1: SP 1= 100, t-1=-0.1; adopts No.1 PID parameters to control;
- StEP2: SP 2=100 , t-2=30.0 Start linear temperature heating up from 100°C, and the time needed 30 minutes to reach SP 2(400 degree).
- StEP3: SP 3=400 , t-3=60.0 Temperature raised to 400°C, slope of raising curve is 10°C/minute, The program take 60 minutes to raise temperature to SP3 (400 degree). It means keep the same temperature in 60 minutes.
- StEP4: SP 4=400 , t-4=120.0 This is the step for temperature cooling down, slope of cooling curve is 2°C/minute, and the time needed is 120 minutes to reach SP4 (160 degree).
- StEP5: SP 5=160 , t-5=0.0 When temperature reached 160°C , the program get in Hold state. If need go to next step, it needed operator to executed the "run" for next step.
- StEP6: SP 6=160 , t-6=-1.0 Jump to StEP1 to start from beginning.

In this example, it is assumed that the deviation high alarm is set to 5°C. Because the temperature of StEP 5 is 160°C, and the temperature of StEP1 is 100°C, when program jumps from StEP 5 to StEP 1, the program will change to preparation state at first(if preparation mode "rdy" was enabled), i.e., Control the temperature until the deviation between setpoint and PV is less than deviation high alarm value. After temperature is controlled to 105°C, the program will be started from StEP 1, and run the above steps again. The temperature control drawing was shown below.

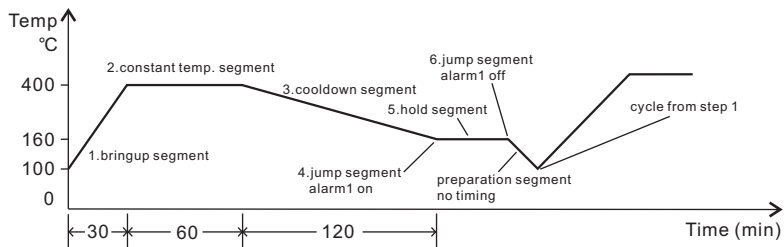

The advantage of using the temperature-time programming method is that the slope of the temperature rise and temperature drop is set to a very wide range. The heating and constant temperature sections have a uniform setting format for easy learning. The setting curve is more flexible, and it can be set to continuously set the temperature rising section (for example, using a warming section with different slopes to approximate the function temperature), or a continuous constant temperature section.

13.2.2 Soak mode(PSYS : B=1)

Suitable for the process which does not need to establish the temperature slope, can simplify the programming and more effective. Each step also can set parameter "rAte" to define temperature raise slope, if "rAte=0" raising speed will set to maximum. Because cannot know the actual time which spend on temperature raising, user can enable "rdy" function to ensure the correct soak time.

13.2.3 Set the given value and time of the program

Each program includes a given value and time, the given value indicates the temperature value to be controlled, time in besides regard as running time, there are special control functions, when t is positive the value represents the running time, when t is negative value represents a jump + command. The meaning is as follows:

The scope of t: -122.0~3200

t-XX=0.1 ~ 3200 represents the run time value

t-XX=0.0 ~ -0.1 ~ -122.0 represents a jump + command

t's command:

0.0, represents that the controller enters the hold running state (HoLd) in this stage, and the program is suspended here and stops the timing.

-121.0, the program executes the StOP operation and enters a stop state.

-XXX.1, represents that first group of PID parameters are specified.

-XXX.2, represents that second group of PID parameters are specified.

-XXX.3, represents that third group of PID parameters are specified.

-XXX.4, represents the AL1 action.

-XXX.5, represents the release of AL1.

-XXX.6, represents the action of AL1 and AL2.

-XXX.7, represents the release of AL1 and AL2.

-XXX.8, indicating that AL1 outputs a 0.5 second pulse action, and the program continues to execute the next segment. However, if the alarm 1 has been activated, whether it is caused by the event output or not, the pulse action is canceled and the alarm 1 state remains unchanged.

For example, if t-1 = -0.1 is set, the first group of PID parameters will be executed and the PIDn parameter will be set to 1 automatically when running to the first-stage program.

For another example, setting t-7 = -11.2 means that when running reaches the program in the 7th stage, it will jump to the 11th stage to execute and specify the second group of PID parameters, and the PIDn parameter will be set to 2 automatically.

For example: Set t-5 = -1.4, which means that when running to the fifth-stage program, AL1 action and jumps to the first-stage running.

Note: In addition to the implementation of the operation or switch on the power to meet the jump segment can continue to jump to run in the program run to allow up to 2 consecutive jumps, continuous 3 or more jumps the program automatically suspended execution (That is, the instrument automatically inserts a suspend operation for three consecutive jumps), an external running operation is required to release the suspended state. Note that if the jump segment is itself (for example, t-6 = -6), the pause state will not be able to be released because such a segment is meaningless.

13.2.4 Multi-group PID application case

SP 1 = any value, t 1 = -0.1, the next paragraph, specify the first group of PID parameters (PIDn parameters automatically 1);

SP 2 = 100, t 2 = 30.0 at 100°C, the linear temperature was raised to SP 3, the temperature rising time was 30 minutes and the temperature rising rate was 10°C/ minute;

SP 3 = 400, t 3 = 60.0, Reach 400°C and keep warm for 60 minutes;

SP 4 = 400, t 4 = -0.2, the next paragraph, specify the second group of PID parameters (PIDn parameters automatically 2);

SP 5 = 400, t 5 = 80, heated to 800°C at 400°C for 80 minutes and heated at a rate of 5°C/ min;

SP 6=800 , t 6=-0.8 , Reach 800°C, AL1 outputs a 0.5 second pulse action and continues to execute the next segment;

SP 7 = 800, t 7 = 120.0, In 800°C and keep warm for 120 minutes;

SP 8 = 800, t 8 = -0.3, continue to the next paragraph, specify the third group of PID parameters (PIDn parameters automatically 3);

SP 9 = 800, t 9= 60.0, heated to 1220°C at 800°C for 60 minutes and heated at a rate of 7°C/ min;

SP 10 = 1220, t 10 = 60, Reach 1220°C and keep warm for 60 minutes;

SP 11 = 1220, t 11 = -121.0, The instrument performs STOP operation, the instrument stops control output, and the program stops running. If it is necessary to re-run the program, press the ∇ key for 2 seconds to make the meter execute RUN and start from the head loop.

13.2.5 Auto-tuning program setting method

For example: auto-tuning the first group PID, auto-tuning target value 400°C.

SP 1 = any value, t 1 = -0.1, the next paragraph, specify the first group of PID parameter groups (if you specify the second group PID parameter group, set t 1 = -0.2, if you specify the third group PID parameter group, then set t 1=-0.3);

SP 2 = 400, t 2 = 100.0 (t 2 is any positive number value), and the auto-tuning target value is 400 °C.

SP 3 = 400, t 3 = -1.0, jump to the first paragraph, so that the program is kept at a constant temperature of 400°C.

After setting the auto-tuning program, set At=on to enable the auto-tuning function.