

**sanwa®**



**CD772**

**DIGITAL MULTIMETER**

**INSTRUCTION MANUAL** **CE**

# Table of Contents

<b>[1]</b>	<b>SAFETY PRECAUTIONS – Before use, read the following safety precautions.–</b>	
1-1	Explanation of Warning Symbols .....	1
1-2	Warning Messages for Safe Use .....	1
1-3	Overload Protection .....	2
<b>[2]</b>	<b>APPLICATIONS AND FEATURES</b>	
2-1	Applications .....	3
2-2	Features .....	3
<b>[3]</b>	<b>NAMES OF COMPONENT UNITS</b>	
3-1	Meter .....	4
3-2	Test Leads .....	4
3-3	Display .....	5
<b>[4]</b>	<b>DESCRIPTION OF FUNCTIONS</b>	
4-1	Power Switch & Function Switch .....	6
4-2	Measuring Function Selection .....	6
4-3	Data Hold .....	6
4-4	Backlight .....	6
4-5	Range Hold .....	7
4-6	Relative Measurement .....	7
4-7	Auto Power Save .....	7
4-8	Battery Low Warning Indication .....	7
4-9	AC Detection Method .....	8
4-10	Crest Factor .....	8
<b>[5]</b>	<b>MEASURING PROCEDURE</b>	
5-1	Start-up Inspection .....	9
5-2	Voltage Measurement (V) .....	10
5-3	Resistance Measurement ( $\Omega$ ), Diode Test ( $\rightarrow$ ), Continuity Check ( $\bullet$ )) .....	11
5-4	Frequency Measurement (Hz) .....	12
5-5	Capacitance Measurement ( $\text{H}$ ) .....	13
5-6	Temperature Measurement ( $^{\circ}\text{C}$ ) .....	14
5-7	Current Measurement ( $\mu\text{A}$ / $\text{mA}$ / $\text{A}$ ) .....	15
<b>[6]</b>	<b>MAINTENANCE</b>	
6-1	Maintenance and Inspection .....	17
6-2	Calibration and Inspection .....	17
6-3	Storage .....	17
6-4	Battery and Fuse Replacement .....	17
<b>[7]</b>	<b>AFTER-SALE SERVICE</b>	
7-1	Warranty and Provision .....	19
7-2	Repair .....	19
7-3	SANWA web site .....	20
<b>[8]</b>	<b>SPECIFICATIONS</b>	
8-1	General Specifications .....	21
8-2	Measuring Range and Accuracy .....	22

## [1] SAFETY PRECAUTIONS

**\*Before use, read the following safety precautions.**

This instruction manual explains how to use your new digital multi meter CD772. Before use, please read this manual thoroughly to ensure correct and safe use. After reading it, keep it together with the product for reference to it when necessary. Using this product in ways not specified in this manual may damage its protection function. The instructions given under the headings of “⚠️ WARNING” and “⚠️ CAUTION” must be followed to prevent accidental **burn** and **electric shock**.

### 1-1 Explanation of Warning Symbols

The meaning of the symbols used in this manual and attached to the product is as follows:

⚠️: **Very important instructions for safe use.**

- The warning messages are intended to prevent accidents to operating personnel such as burn and electric shock.
- The caution messages are intended to prevent incorrect handling which may damage the product.

⚡ : High voltage hazard

⏚ : Ground

—|—|—| : Direct current (DC)

Hz : Frequency

~ : Alternating current (AC)

⏚ : Capacitor

Ω : Resistance

°C : Temperature

➔ : Diode

☀️ : Backlight

•)) : Buzzer

⏚ : Fuse

□ : Double insulation or reinforced insulation

### 1-2 Warning Messages for Safe Use

#### ⚠️ WARNING

The following instructions are intended to prevent personal injury such as burn and electric shock. Be sure to follow them when using the meter:

1. Never use the meter for power lines exceeding 6 kVA.
2. Voltages above 70VDC or 33Vrms AC (46.7V peak) are hazardous to human body. Take care so as not to touch them.
3. Never input signals exceeding the maximum rated input value (see 1-3).
4. Never use the meter for measuring voltages of lines connected to equipment (e.g. motors) that generates induced or surge voltage since it may exceed the maximum allowable overload input.

5. Never use the meter near equipment which generates strong electromagnetic waves or is charged.
6. Never use the meter if the meter or test leads are damaged or broken.
7. Never use the meter with the case or battery lid removed.
8. Be sure to use the fuse of the specified rating and specification.
9. During measurement, do not hold the test pin side of the flange of the test leads.
10. To start measurement, first connect the ground side (black test lead). When disconnecting, the ground side must be disconnected last.
11. During measurement, do not change the meter to another function or range nor replace the plugs to other terminals.
12. Before starting measurement, make sure that the function and range are properly set.
13. Never use the meter when it is wet or with wet hands.
14. Be sure to use the specified type of test leads.
15. Never attempt repair or modification, except for battery and fuse replacement.
16. Inspect the meter at least once a year.
17. This meter is for indoor use only.

**⚠ CAUTION**

Correct measurement may not be performed when using the meter in the ferromagnetic / intense electric field such as places near a transformer, a high-current circuit, and a radio.

### 1-3 Overload Protection

The maximum rated input value and overload protection have been established for the input terminals of each function.

Function	Input Terminal	Max. Rated Input Value	Max. Overload Protection Input Value
<b>V · Hz</b>	<b>V/Hz/⚡</b> <b>Ω / → / ∙) ∙ ←</b> and <b>COM</b>	DC/AC1000V	DC/AC1000V
<b>Ω / → / ∙) ∙ ←</b>		⚠ Do not input a voltage or current.	
<b>°C</b>	<b>°C+</b> and <b>°C-</b>	DC50mV	0.5A/1000V fuse Breaking capacity 30kA
<b>μA</b>	<b>μA</b> <b>mA</b> and <b>COM</b>	DC/AC4000μA ⚠ Do not input a voltage.	
<b>mA</b>		DC/AC400mA ⚠ Do not input a voltage.	
<b>A</b>	<b>15A</b> and <b>COM</b>	DC/AC15A ⚠ Do not input a voltage.	16A/1000V fuse Breaking capacity 30kA

## [2] APPLICATIONS AND FEATURES

### 2-1 Applications

This is a digital multimeter designed for measurement in the ranges of CAT. II 1000V and CAT. III 600V. This meter is useful for measuring / analyzing circuits of small communication devices, home electric appliances and batteries within the CAT. III environment.

### 2-2 Features

- Safety design in compliance with the IEC61010-1. The current terminal is protected with a safety cap.
- True RMS sensing for alternating current (AC).
- Temperature (°C) measuring function provided.  
(For K type thermocouple temperature sensor).
- Continuity confirmed by the buzzer and red LED lamp.
- Eye-friendly largesized display.
- Frequency measurement and capacitance measurement functions provided.
- Easy-to-hold design.
- Test probes can be secured to the body.
- Double molding with outside made of elastic elastomer material.

### Classification of overvoltage measurement

#### **Overvoltage measurement classification (CAT. I):**

Line on the secondary side on the inside of equipment via a transformer, etc. from the receptacle.

#### **Overvoltage measurement classification (CAT. II):**

Line on the primary side of equipment with power cord to be connected to the receptacle.

#### **Overvoltage measurement classification (CAT. III):**

Line from the primary side or branch of equipment which directly takes in electricity from a distribution board to the receptacle.

#### **Overvoltage measurement classification (CAT. IV):**

Line from the service conductor to the distribution board.

### [3] NAMES OF COMPONENT UNITS

#### 3-1 Meter

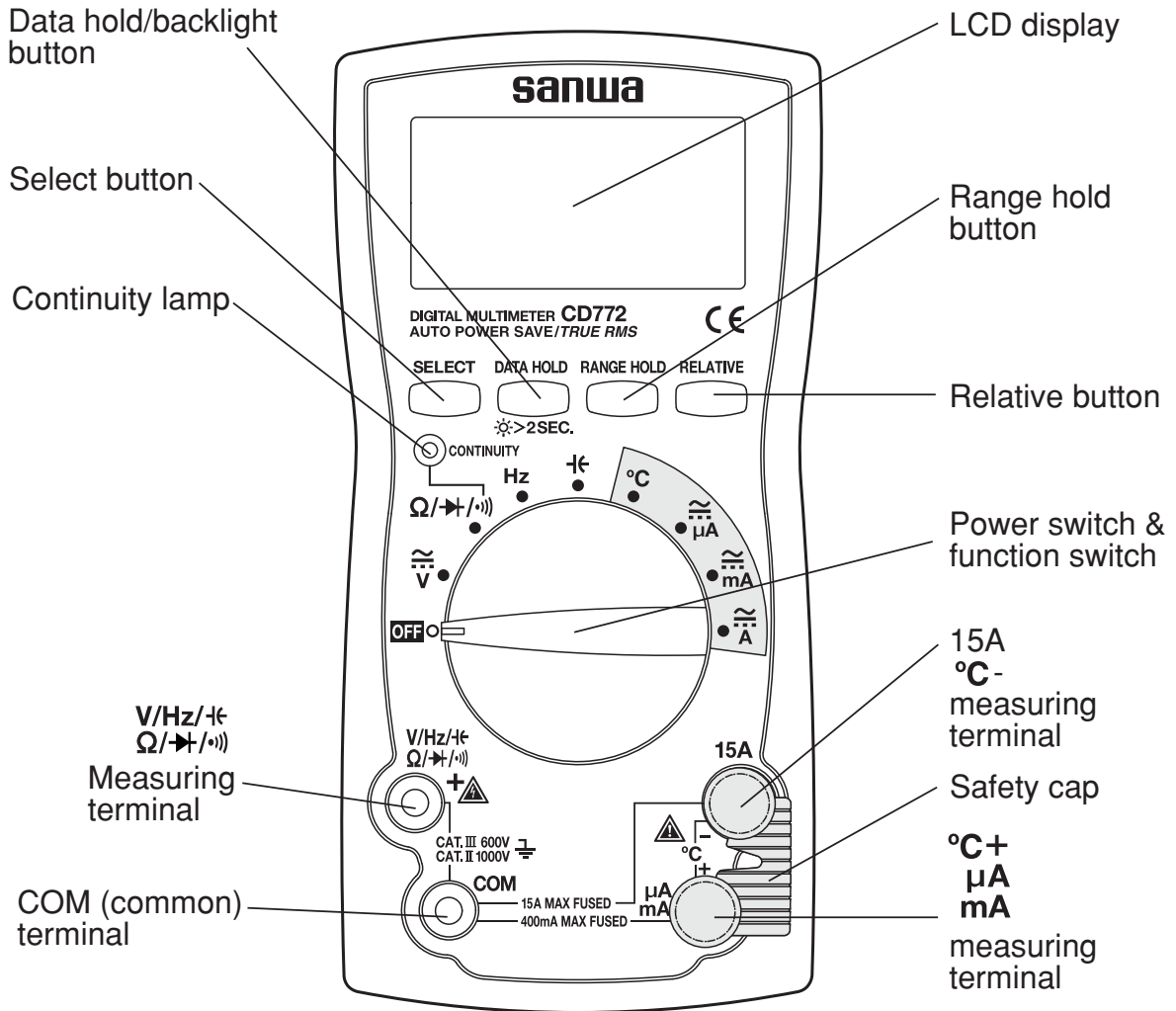

#### 3-2 Test Leads

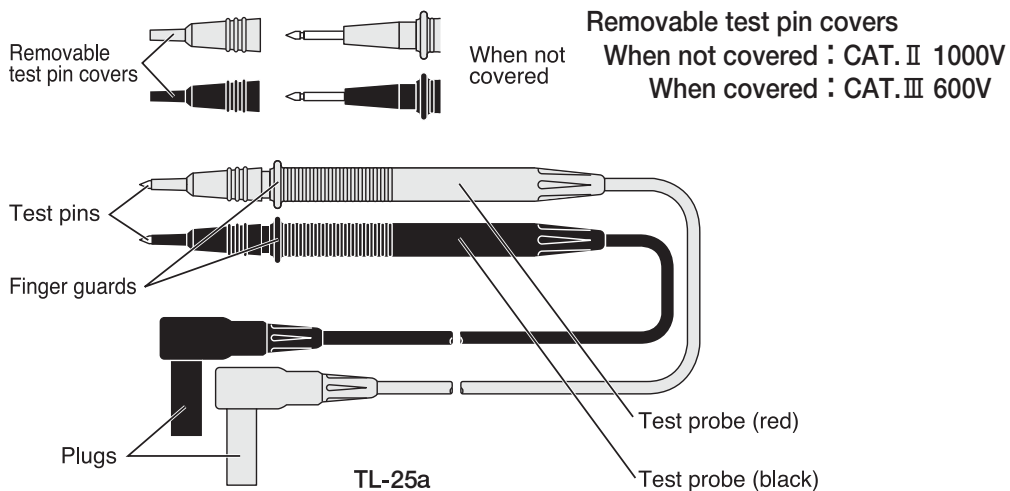

### 3-3 Display

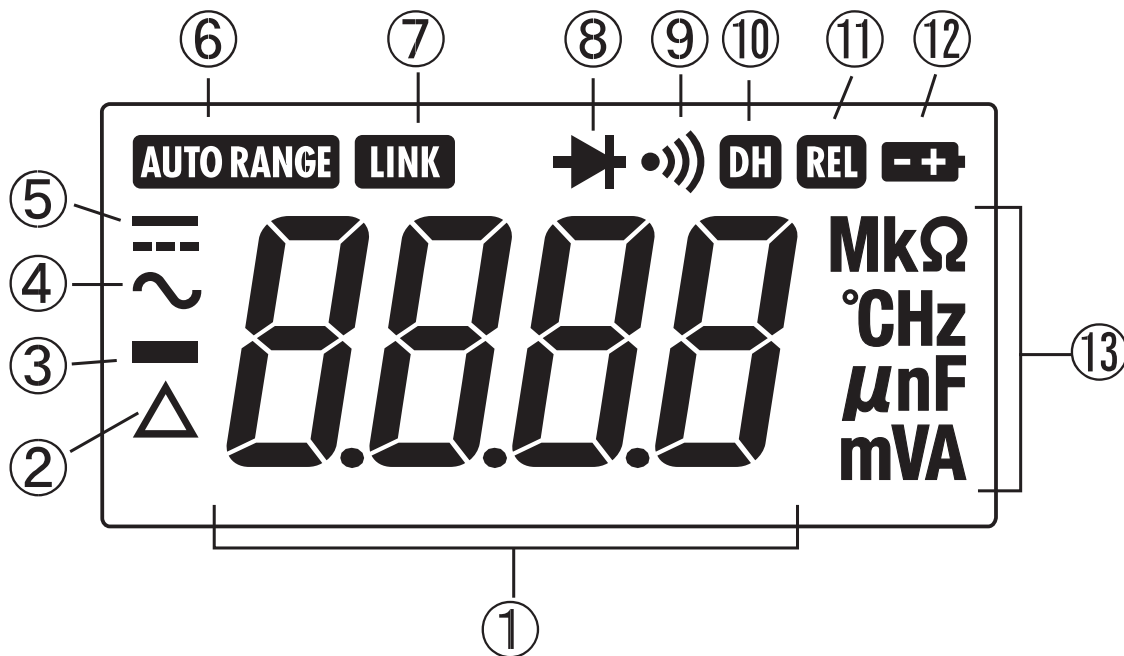

①	Indication of numerical value.
②	Indication of relative mode operation.
③	Indication of negative sign of numerical data.
④	Indication of AC measuring function operation.
⑤	Indication of DC measuring function operation.
⑥	Indication of auto range mode operation.
⑦	Not used with this meter.
⑧	Indication of diode test function operation.
⑨	Indication of continuity check function operation.
⑩	Indication of data hold mode operation.
⑪	Indication of relative mode operation.
⑫	Indication of battery low warning.
⑬	Indication of units of measurement.

















## [4] DESCRIPTION OF FUNCTIONS

### 4-1 Power Switch & Function Switch

Turn this switch to turn on and off the power and select a measuring function.

### 4-2 Measuring Function Selection: SELECT

When the **SELECT** button is pressed, the functions change as follows:

- V position: DC voltage (  ) → AC voltage (  ) → DC voltage (  )
- $\Omega$  /  /  position: Resistance measurement (  $\Omega$  ) → diode test (  ) → continuity check (  ) → resistance measurement (  $\Omega$  )
- $\mu$ A position: DC current (  ) → AC current (  ) → DC current (  )
- mA position: DC current (  ) → AC current (  ) → DC current (  )
- A position: DC current (  ) → AC current (  ) → DC current (  )

### 4-3 Data Hold: DATA HOLD

When the **DATA HOLD** button is pressed, the value indicated will be held. (“**DH**” will appear on the display.) The indicated value will not change if the measurement input fluctuates.

When this button is pressed again, the hold status will be canceled and the meter will return to the measurement mode. (“**DH**” will disappear from the display.)

### Remarks:

- The **DATA HOLD** button does not work with the Hz function.

### 4-4 Backlight:

When the (  ) button is held pressed for 2 seconds or longer, the backlight will be turned on. To turn it off, hold this button pressed for 2 seconds or longer again.

### Remarks:

- Because the (  ) button serves as the **DATA HOLD** button also, when the backlight is turned on, the data hold mode will be set. To cancel the data hold mode, press this button momentarily (less than 2 seconds) again.



#### 4-5 Range Hold: RANGE HOLD

When the **RANGE HOLD** button is pressed, the meter will be set in the manual mode and the range will be fixed. (“**AUTORANGE**” will disappear from the display.) In the manual mode, each time this button is pressed, the range changes. While checking the unit and decimal point on the display, select the best range.

To return to the auto range, hold this button pressed for 1 second or longer. (“**AUTORANGE**” will appear on the display.)

#### Remarks:

- The RANGE HOLD button does not work with the (Hz), (→), (•) and (←) functions.

#### 4-6 Relative Measurement: RELATIVE

When the **RELATIVE** button is pressed, **REL** and  $\Delta$  will light and the input value when the button was pressed will become 0 as the reference. To cancel it, press the button again.

Example: Display after pressing the button at DC30.00V input

Actual Input Value	Value in Display
DC 30.00V	DC 00.00V
DC 35.00V	DC 05.00V
DC 25.00V	DC -05.00V

#### Remarks:

- This mode cannot be used with the **Hz** function. When a function other than (←) is used, the range is fixed during relative measurement.

#### 4-7 Auto Power Save

The tester enters “power save mode” automatically if it has been operated for about 30 minutes. Please note, a small electric current from power supply is present in Auto Power Save mode. Be sure to set the power / function switch to “OFF” after measurement.

To cancel Auto Power Save function, turn the power / function switch from OFF position to any desired function while holding the **SELECT** button pressed.

#### 4-8 Battery Low Warning Indication

When the built-in batteries have been discharged and the voltage has dropped to below about 2.4 V, “” mark will appear in the display. When this mark flickers or lights, replace both two batteries with new ones.

#### 4-9 AC Detection Method

This meter employs the root-mean-square value method and indicates the magnitude of AC as the same amount of work as DC. Root-mean-square values of sinusoidal waves and such non-sinusoidal waves as square waves and chopping waves can be measured by the true RMS (Root Mean Square) circuit.

#### 4-10 Crest Factor

The CR (crest factor) indicates the peak value of a signal by dividing it by its root-mean-square value. With most common waveforms such as sinusoidal wave and chopping wave, the crest factor is relatively low. With waveforms similar to low duty cycle pulse trains, the crest factor is high. For the voltages and crest factors for typical waveforms, see the table below.

Please measure the crest factor by 3 or less.

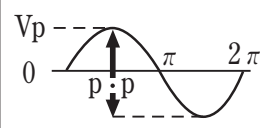
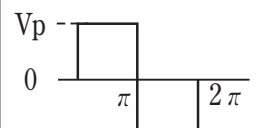
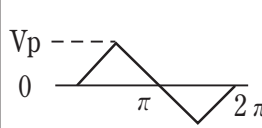
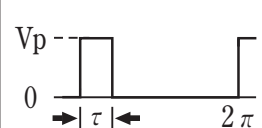
	Input Waveform	0 to PEAK $V_p$	Root Mean Square Value $V_{rms}$	Average Value $V_{avg}$	Crest Factor $V_p/V_{rms}$	Form Factor $V_{rms}/V_{avg}$
Sinusoidal wave		$V_p$	$\frac{V_p}{\sqrt{2}}$ $=0.707V_p$	$\frac{2V_p}{\pi}$ $=0.637V_p$	$\sqrt{2}$ $=1.414$	$\frac{\pi}{2\sqrt{2}}$ $=1.111$
Square wave		$V_p$	$V_p$	$V_p$	1	1
Chopping wave		$V_p$	$\frac{V_p}{\sqrt{3}}$ $=0.577V_p$	$\frac{V_p}{2}$ $=0.5V_p$	$\sqrt{3}$ $=1.732$	$\frac{2}{\sqrt{3}}$ $=1.155$
Pulse		$V_p$	$\sqrt{\frac{\tau}{2\pi}} \cdot V_p$	$\frac{\tau}{2\pi} \cdot V_p$	$\sqrt{\frac{2\pi}{\tau}}$	$\sqrt{\frac{2\pi}{\tau}}$

#### Voltages of Various Waveforms

- This meter employs AC coupling for AC measurement. The DC components in input signals are cut.

## [5] MEASURING PROCEDURE

### ⚠ WARNING

1. Do not apply an input signal exceeding the maximum rated input of each function.
2. During measurement, do not change the function switch.
3. During measurement, do not touch the test pin side of the flange of the test lead.
4. When measurement has been finished, remove the test pins from the object measured and return the function switch to the **OFF** position.

### 5-1 Start-up Inspection

### ⚠ CAUTION

1. Be sure that the battery low warning mark is not flickering or lit, when the meter is turned on. If it is flickering or lit, replace the batteries with new ones.
2. Do not use the meter if the meter or test lead is damaged or broken.
3. Make sure the test leads are not cut and the fuse has not blown.

Always conduct the start-up inspection to ensure safety. (Inspection by the continuity check.)

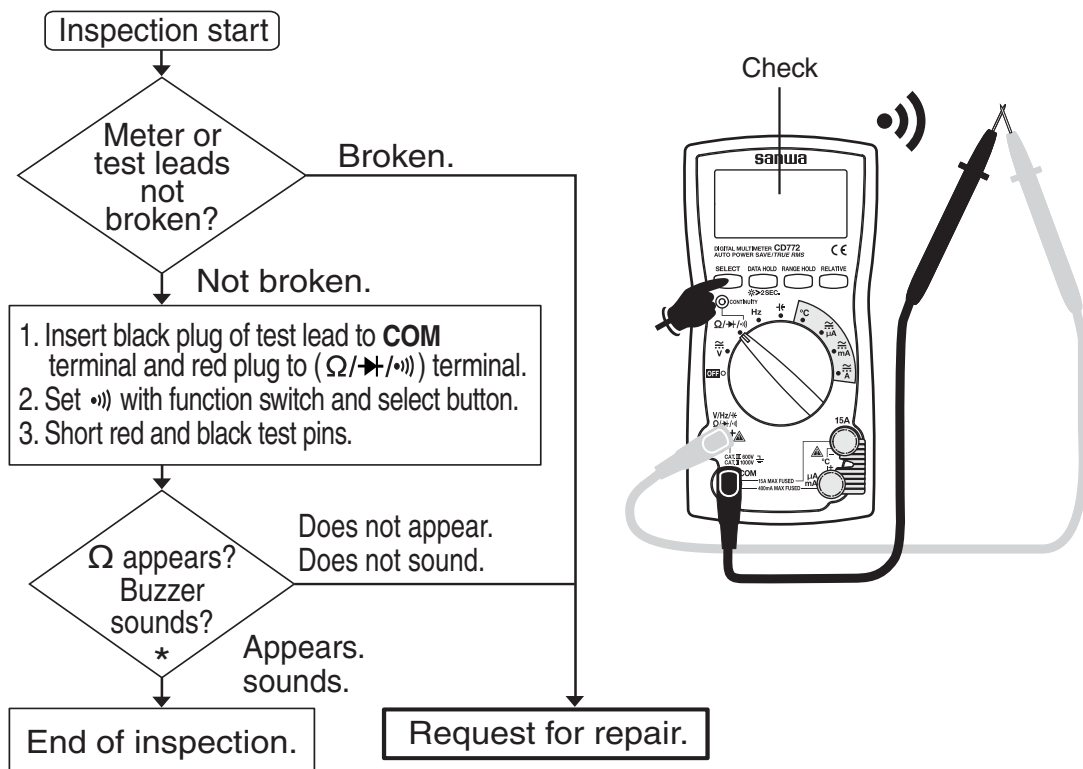

\* If nothing appears on the display, the batteries might have been discharged completely.

## 5-2 Voltage Measurement (V)

Function	Max. Rated Input	Range
DCV	DC 1000V	400.0mV, 4.000V, 40.00V, 400.0V, 1000V
ACV	AC 1000V	4.000V, 40.00V, 400.0V, 1000V

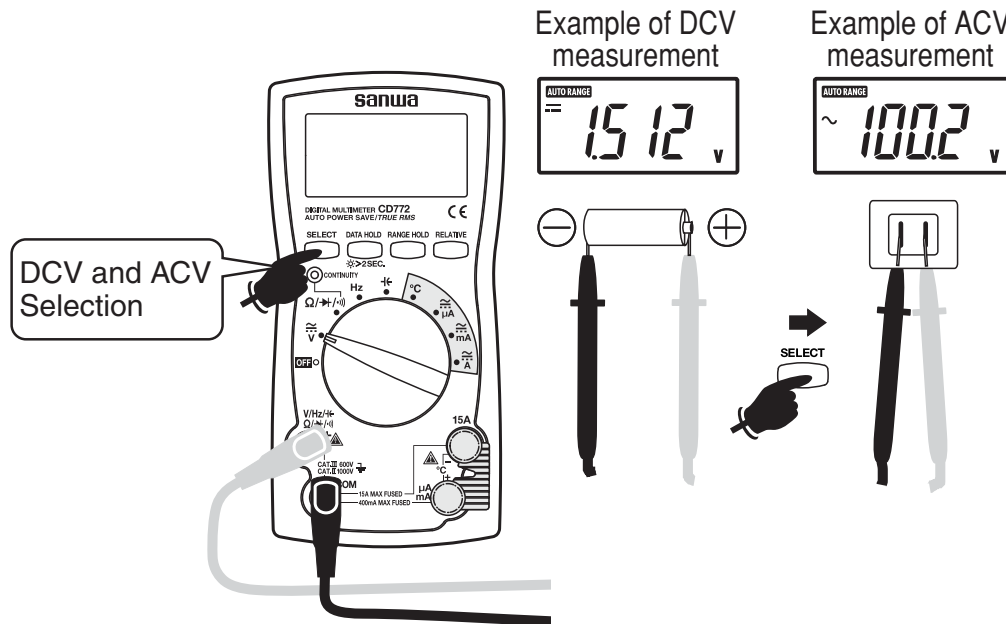

### Remarks:

- This meter is of true root-mean-square value response (AC coupling). The accuracy guarantee range is as follows:  
 AC frequency bandwidth: 4V range 45 – 500 Hz  
 40V range and over 45 – 1kHz  
 Crest factor (CF) range: 3 max.  
 Range: 5% to 100% of each range
- The indication may fluctuate when the test leads are released. It is not a failure.
- The AC400.0mV range can be selected with the **RANGE HOLD** button, but the accuracy is not guaranteed.

### 5-3 Resistance Measurement ( $\Omega$ ), Diode Test ( $\rightarrow$ ), Continuity Check ( $\bullet$ )

#### ⚠ WARNING

Never apply a voltage to the measuring terminals.

#### 5-3-1 Resistance measurement ( $\Omega$ )

Function	Max. Rated Input	Range
$\Omega$	40.00M $\Omega$	400.0 $\Omega$ , 4.000k $\Omega$ , 40.00k $\Omega$ , 400.0k $\Omega$ , 4.000M $\Omega$ , 40.00M $\Omega$

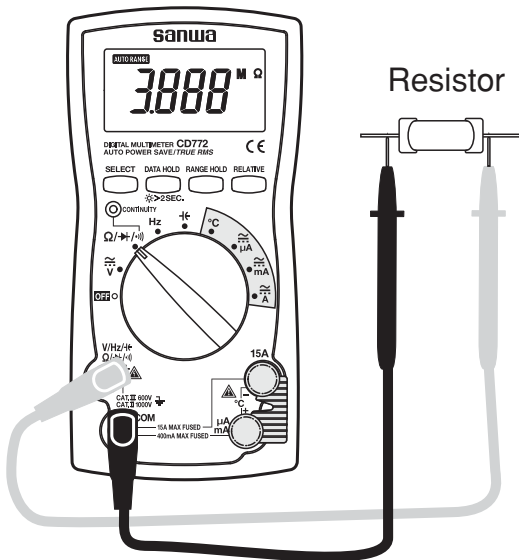

#### Remarks:

If measurement is affected by noises, shield the object to measure with COM potential. If measurement is conducted with a finger touching the test pins, an error will occur due to influence of resistance of the human body. The open voltage between the measuring terminals is approx. 0.4 VDC.

#### 5-3-2 Diode test ( $\rightarrow$ )

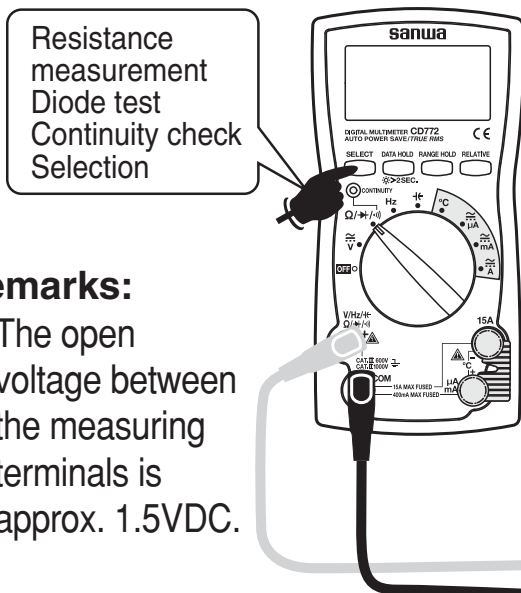

#### Remarks:

The open voltage between the measuring terminals is approx. 1.5VDC.

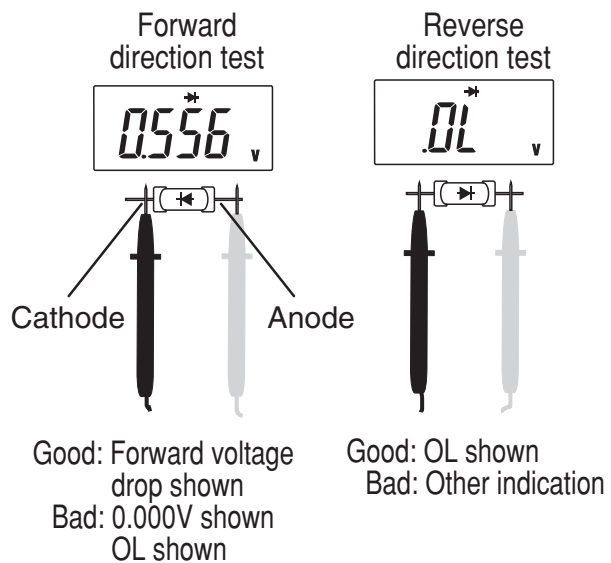

### 5-3-3 Continuity check (•|||)

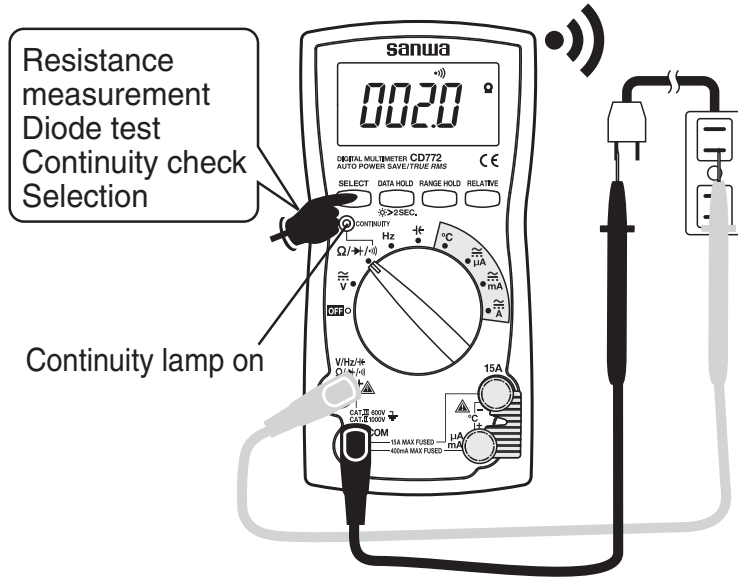

#### Remarks:

- Continuity buzzer sound and continuity lamp on range:  $0 \Omega \sim 85 \Omega (\pm 45 \Omega)$

### 5-4 Frequency Measurement ( Hz )

#### ⚠ CAUTION

Never use the meter for measuring frequencies to ground as the earth leakage breaker may trip.

Measurement prohibited

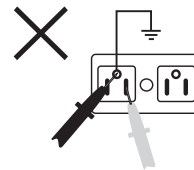

Function	Max. Rated Input	Range
Hz	100.0kHz ( $\leq 1000\text{Vrms}$ )	5.000Hz, 50.00Hz, 500.0Hz, 5.000kHz, 50.00kHz, 100.0kHz (Auto range only)

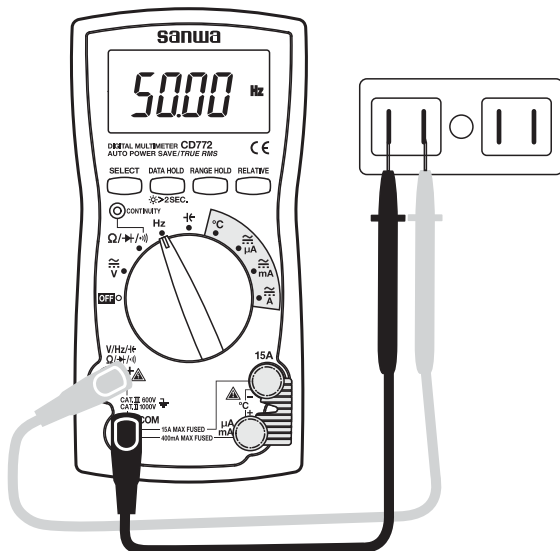

#### Remarks:

- Because the Hz function uses input resistance as low as approx.  $2 \text{ k}\Omega$ , a large amount of current will flow during measurement. Never use the meter for measuring circuits or devices having a small current capacity.

## Remarks:

- Input sensitivity: 3 Vrms or over
- Zero cross (+ potential → - potential → + potential) frequencies can be measured. Frequencies of + potential only or - potential only such as logic pulses cannot be measured.
- Frequencies less than 1 Hz cannot be measured.
- When the Hz function is used, the data hold and relative function cannot be used.

## 5-5 Capacitance Measurement ( $\overleftarrow{\leftarrow}$ )

### ⚠ WARNING

Never apply a voltage to the measuring terminals.

### ⚠ CAUTION

1. Remove electric charge in the capacitor prior to measurement.
2. Because this meter applies a current to the capacitor to measure, it is not suitable for measurement of electrolytic capacitors having a large leak current as a large error will occur.
3. For capacitors having large capacitance, measurement takes a longer time.

Function	Max. Rated Input	Range
CAP( $\overleftarrow{\leftarrow}$ )	100.0 $\mu$ F	50.00nF, 500.0nF, 5.000 $\mu$ F, 50.00 $\mu$ F, 100.0 $\mu$ F (Auto range)

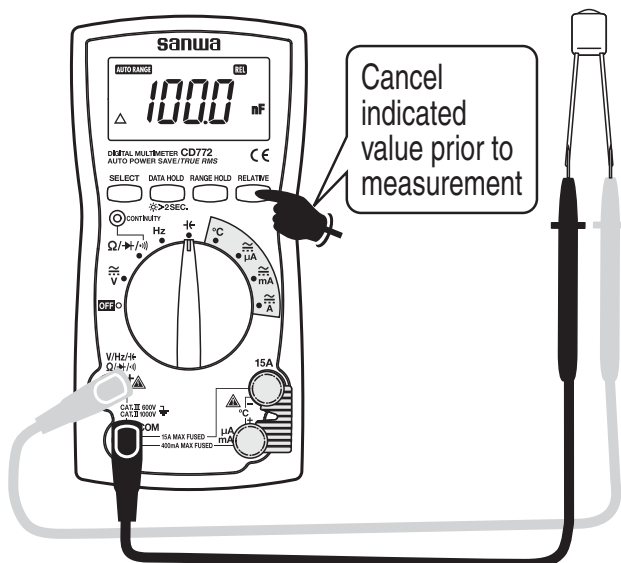

## Remarks:

- For capacitance measurement, press the **RELATIVE** button to cancel the indicated value (00.00nF) before connecting a capacitor.
- Only the auto range is available for the capacitance measuring function.
- The indication may not become stable due to influence of surrounding noises or stray capacitance of the test leads.

## 5-6 Temperature Measurement (°C)

### ⚠ WARNING

Measuring temperature involves such hazard as getting burnt depending on temperatures to measure and measuring environment.

### ⚠ CAUTION

Do not apply a voltage above 50 mV DC to the input terminal.

Function	Input Terminal	Measuring Range	Built-in Fuse
°C	°C+ and °C-	-20.0°C ~ 300.0°C	0.5A/1000V Fuse Breaking capacity 30kA and 16A/1000V Fuse Breaking capacity 30kA

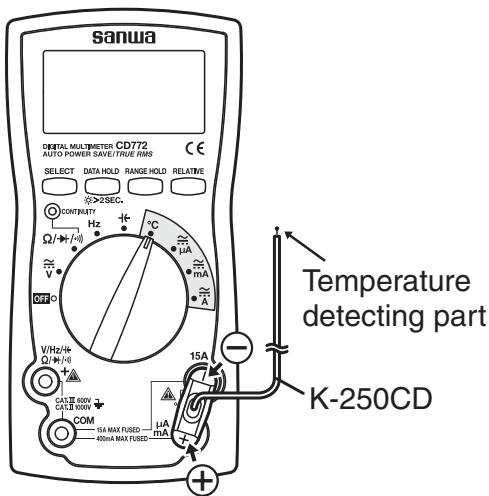

### Remarks:

- The temperature (°C) measuring function of this meter is designed for the K type thermocouple.
- For measurement, insert the included temperature sensor (K-250CD) with correct polarity (+ and -).

- When the optional K type adapter (K-AD) is used, the temperature sensor with international standard mini plug can be used.

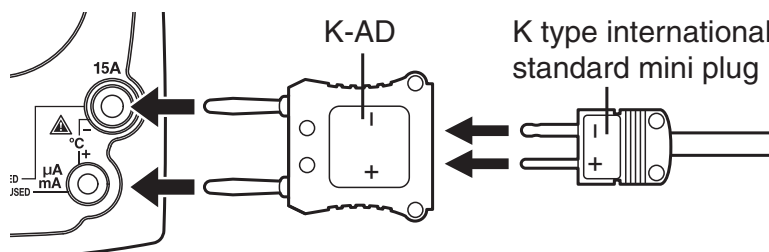



## 5-7 Current Measurement ( $\mu\text{A}$ / $\text{mA}$ / $\text{A}$ )

### ⚠ WARNING

1. Never apply a voltage to the measuring terminals.
2. Never apply an input exceeding the maximum rated current.
3. Be sure to connect the meter in series via a load.

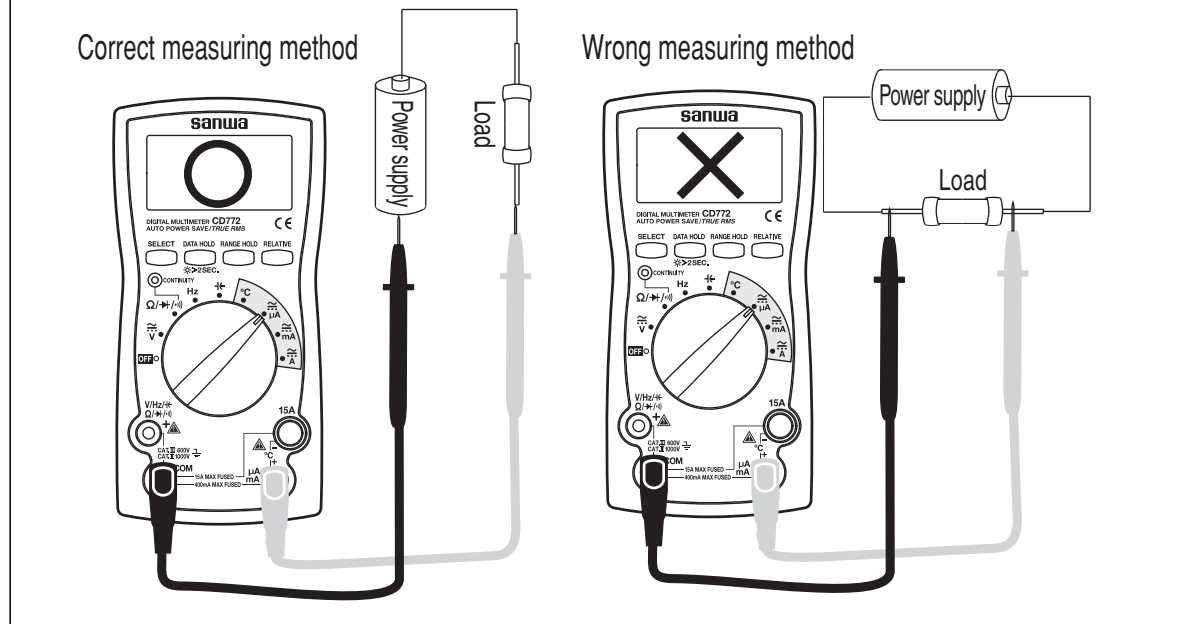

### ⚠ CAUTION

Be sure that the built-in fuse has not blown.

Function	Max. Rated Input	Range
DC/AC $\mu\text{A}$	4000 $\mu\text{A}$	400.0 $\mu\text{A}$ , 4000 $\mu\text{A}$
DC/AC $\text{mA}$	400 $\text{mA}$	40.00 $\text{mA}$ , 400.0 $\text{mA}$
DC/AC $\text{A}$	15 $\text{A}$	4.000 $\text{A}$ , 15.00 $\text{A}$

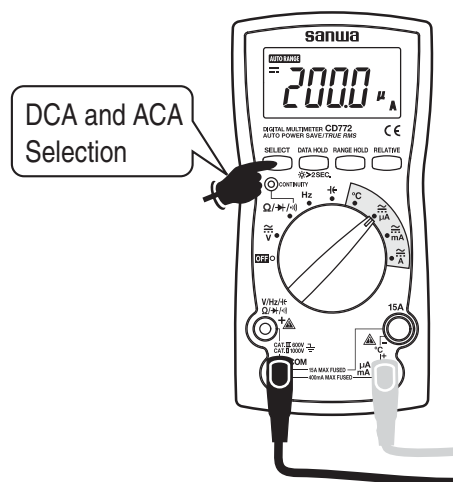

### Remarks:

- In current measurement, the internal resistance of the current range is placed in series and the current drops by this resistance. Accordingly, its influence becomes larger in low-resistance circuits.
- The AC accuracy guarantee frequency range is from 45 Hz to 1kHz.
- Current range: Auto range for 400.0  $\mu\text{A}$  ~ 4000  $\mu\text{A}$ , 40.00  $\text{mA}$  ~ 400.0  $\text{mA}$  and 4.000  $\text{A}$  ~ 15.00  $\text{A}$ . The range may be fixed by the RANGE HOLD button.

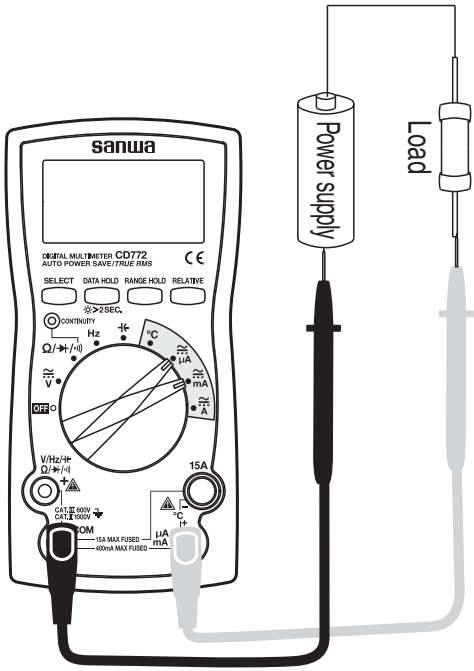

### µA · mA measurement

Function	Input Terminal	Built-in Fuse
µA	µA and COM	0.5A/1000V Fuse Breaking capacity 30kA
mA		

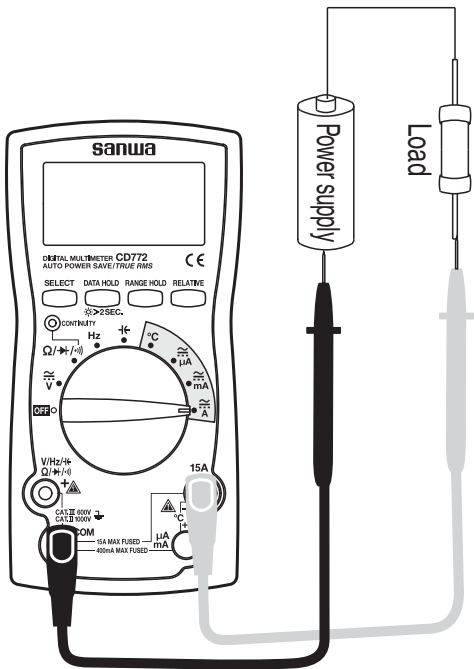

### A measurement

Function	Input Terminal	Built-in Fuse
A	15A and COM	16A/1000V Fuse Breaking capacity 30kA

### Remarks:

- Maximum 20A can be measured if the measurement time is less than 10 seconds.  
(Take 10minutes or longer intervals between measurements.)

- If the indication will change little when an input signal is applied or a current value which is significantly smaller than the expected value is indicated, possible causes are the input terminals, incorrect setting of the function switch, or blown fuse. Check these places.

## [6] MAINTENANCE

### WARNING

1. The following instructions are very important for safety.  
Read this manual thoroughly to ensure correct maintenance.
2. Calibrate and inspect the meter at least once a year to ensure safety and maintain its accuracy.

#### 6-1 Maintenance and Inspection

- 1) Appearance: Is the meter not damaged due to falling or other cause?
- 2) Test leads:
  - Are the core wires not exposed from the test leads?
  - Is the plug when inserted to the input terminal not loose?If any of the above problems exists, stop using the meter and request for repair.

#### 6-2 Calibration and Inspection

For more information, please contact Sanwa's authorized agent / distribute service provider, listed in our website.  
See section 7-3.

#### 6-3 Storage

### CAUTION

1. The panel and case are not resistant to volatile solvent and must not be cleaned with thinner or alcohol.
2. The panel and case are not resistant to heat. Do not place the meter near heat-generating devices.
3. Do not store the meter in a place where it may be subjected to vibration or where it may fall.
4. Do not store the meter in places under direct sunlight, or hot, cold or humid places or places where condensation is anticipated.
5. If the meter will not be used for a long time, remove the batteries.

#### 6-4 Battery and Fuse Replacement

##### **Batteries when the meter is shipped:**

A battery for monitoring has been installed prior to shipment from the factory. It may be discharged before the expiration of the described battery life.

\*The battery for monitoring is a battery used to check the functions and performance of the product.

**⚠ WARNING**

1. To avoid electric shock, do not remove the rear case with an input being applied to the measuring terminals. Also, before starting replacement, make sure the power of the meter is OFF.
2. Be sure to use the replacement fuse of the same rating. Never use a substitute for the fuse nor short the meter.

### 6-4-1 Battery replacement

- ① Remove the fixing screw of the battery holder with a screwdriver.
- ② Replace both two batteries in the battery holder with new ones.  
(Pay attention to their polarity.)
- ③ Set and secure the battery holder with the fixing screw as before.

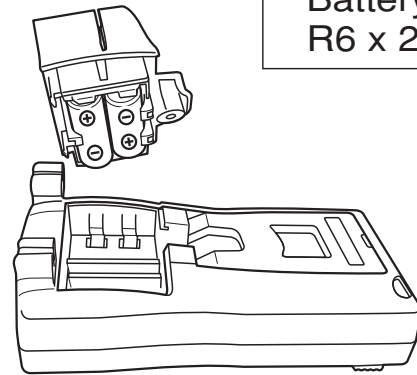
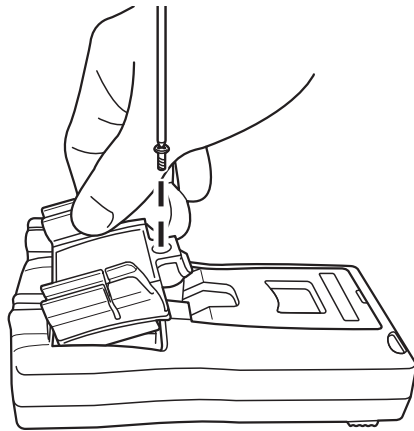

Battery:  
R6 x 2 pieces

### 6-4-2 Fuse replacement

- ① Remove the screws of the body rear case with a screwdriver.
- ② Take out the fuse and replace it with a new one.
- ③ Secure the rear case with the screws as before.

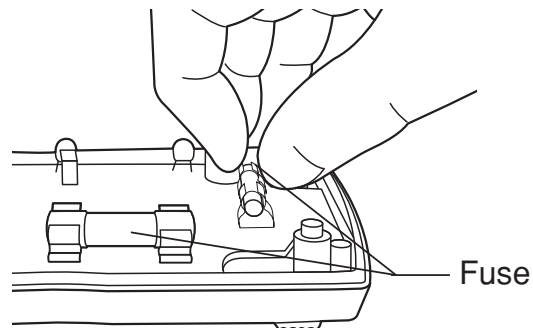
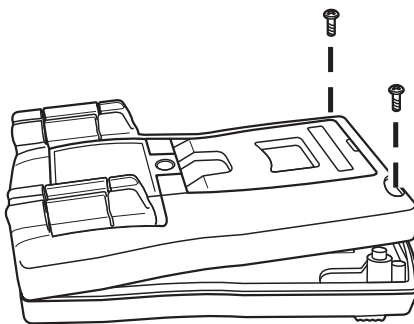

#### **Fuse rating:**

0.5A/1000V (ø6.35 x 32 mm, Breaking capacity 30kA)

16A/1000V (ø10 x 38 mm, Breaking capacity 30kA)

\* Spare fuse storage is provided at the bottom of the rear case. (For ø6.35 x 32 mm fuse only)

## **[7] AFTER-SALE SERVICE**

### **7-1 Warranty and Provision**

Sanwa offers comprehensive warranty services to its end-users and to its product resellers. Under Sanwa's general warranty policy, each instrument is warranted to be free from defects in workmanship or material under normal use for the period of one (1) year from the date of purchase.

This warranty policy is valid within the country of purchase only, and applied only to the product purchased from Sanwa authorized agent or distributor.

Sanwa reserves the right to inspect all warranty claims to determine the extent to which the warranty policy shall apply. This warranty shall not apply to disposables batteries, or any product or parts, which have been subject to one of the following causes:

1. A failure due to improper handling or use that deviates from the instruction manual.
2. A failure due to inadequate repair or modification by people other than Sanwa service personnel.
3. A failure due to causes not attributable to this product such as fire, flood and other natural disaster.
4. Non-operation due to a discharged battery.
5. A failure or damage due to transportation, relocation or dropping after the purchase.

### **7-2 Repair**

Customers are asked to provide the following information when requesting services:

1. Customer name, address, and contact information
2. Description of problem
3. Description of product configuration
4. Model Number
5. Product Serial Number
6. Proof of Date-of-Purchase
7. Where you purchased the product

Please contact Sanwa authorized agent / distributor / service provider, listed in our website, in your country with above information. An instrument sent to Sanwa / agent / distributor without above information will be returned to the customer.

**Note:**

- 1) Prior to requesting repair, please check the following:  
Capacity of the built-in battery, polarity of installation and discontinuity of the test leads.
- 2) Repair during the warranty period:  
The failed meter will be repaired in accordance with the conditions stipulated in 7-1 Warranty and Provision.
- 3) Repair after the warranty period has expired:  
In some cases, repair and transportation cost may become higher than the price of the product. Please contact Sanwa authorized agent / service provider in advance.  
The minimum retention period of service functional parts is 6 years after the discontinuation of manufacture. This retention period is the repair warranty period. Please note, however, if such functional parts become unavailable for reasons of discontinuation of manufacture, etc., the retention period may become shorter accordingly.
- 4) Precautions when sending the product to be repaired  
To ensure the safety of the product during transportation, place the product in a box that is larger than the product 5 times or more in volume and fill cushion materials fully and then clearly mark "Repair Product Enclosed" on the box surface. The cost of sending and returning the product shall be borne by the customer.

**7-3 SANWA web site**

<http://www.sanwa-meter.co.jp>

E-mail: [exp\\_sales@sanwa-meter.co.jp](mailto:exp_sales@sanwa-meter.co.jp)

## [8] SPECIFICATIONS

### 8-1 General Specifications

Operation method	$\Delta$ - $\Sigma$ method
AC measuring method	True RMS value method
LCD	4000 counts
Sampling rate	Approx. 3 times/sec.
Range selection	Auto and Manual (Some with Manual only or Auto only)
Over-range indication	"OL" shown in numerical part. (1000V DC/AC, 10A excluded.)
Polarity indication automatic selection	"—" indicated only when negative input.
Battery low warning	Battery (  ) mark lights or flickers at approx. 2.4 V or below.
Environmental condition	Altitude 2000 m or below, pollution degree II.
Operating temperature / humidity	5°C to 40°C and humidity range as follows. No condensation allowed. At 5°C to 31°C, 80% RH (max). At 31°C to 40°C, linear drop from 80% RH to 50% RH.
Storage temperature / humidity	-10°C ~ 40°C, 80%RH max., no condensation 40°C ~ 50 °C, 70%RH max., no condensation (When the meter will not be used for a long time, remove the batteries before storage.)
Power supply	SUM-3 (R6), 2 pieces
Battery life	About 150 hours continuously at DCV. (Auto power save canceled)
Auto power save	Power save about 30 minutes after no operation.
Fuse	0.5A/1000V, Breaking capacity 30kA 16A/1000V, Breaking capacity 30kA
Safety standards	IEC61010-1 CAT.III 600V CAT.II 1000V IEC61010-031: 2008
EMC Directive	IEC61326
Dimensions	166(L) X 82(W) X 44(D) mm (Projections not included)
Weight	Approx. 360 g (batteries included)
Power consumption	Typical 15mW (at DCV)
Standard accessories included	Test lead (TL-25a), K type thermocouple temperature sensor (K-250CD), Instruction manual
Optional accessories	Alligator clip: CL-11, CL-15, TL-8IC Clamp probe: CL-22AD, CL-33DC, CL-20D Temperature probe: K-8-800, K-8-650, K-8-300, K-8-500, K-8-250 K-type adapter: K-AD High voltage probe: HV-60 Carrying case: C-77, C77H

## 8-2 Measuring Range and Accuracy

Temperature:  $23\pm 5^{\circ}\text{C}$ , humidity: 80% RH max. (no condensation), voltage 2.4 V or above.

rdg (reading): Read value, dgt (digit): Number of counts of last digit

### DCV voltage

Range	Accuracy	Input Resistance	Remarks
400.0mV	$\pm(0.9\%rdg+2dgt)$	$\geq$ Approx. 100M $\Omega$	
4.000V		Approx. 11M $\Omega$	
40.00V		Approx. 10M $\Omega$	
400.0V			
1000V			

### ACV voltage

Range	Accuracy	Input Resistance	Remarks
4.000V	$\pm(1.2\%rdg+8dgt)$	Approx. 11M $\Omega$	Accuracy guaranteed frequency range: 4V range 45Hz ~ 500Hz 40V range and over 45Hz ~ 1kHz Crest factor (CF) range: 3 max. Range: 5% to 100% of each range
40.00V		Approx. 10M $\Omega$	
400.0V			
1000V			

### Resistance measurement

Range	Accuracy	Remarks
400.0 $\Omega$	$\pm(1.2\%rdg+5dgt)$	<ul style="list-style-type: none"> <li>• Open circuit voltage: Approx. 0.4 VDC</li> <li>• The measuring current varies depending on resistance of resistors to measure.</li> </ul>
4.000k $\Omega$		
40.00k $\Omega$		
400.0k $\Omega$		
4.000M $\Omega$	$\pm(2.0\%rdg+3dgt)$	
40.00M $\Omega$	$\pm(3.0\%rdg+3dgt)$	

### Diode test

Open circuit voltage: Approx. 1.5 VDC

### Continuity check

Buzzer sound and continuity lamp on range: 0  $\Omega$  ~ 85  $\Omega$  ( $\pm 45$   $\Omega$ )

Open circuit voltage: Approx. 0.4 VDC

### Temperature measurement

Range	Accuracy	Remarks
-20.0 $^{\circ}\text{C}$ ~300.0 $^{\circ}\text{C}$	$\pm(3.0\%rdg+30dgt)$	Accuracy of the K type thermocouple range. Accuracy of the thermocouple is not included.



## Frequency

Range	Accuracy	Remarks
5.000Hz	$\pm(0.3\%rdg+3dgt)$	<ul style="list-style-type: none"> <li>• Auto range only</li> <li>• The data hold and relative functions cannot be used.</li> <li>• Sensitivity: 3 Vrms or over.</li> <li>• Frequency less than 1 Hz cannot be measured.</li> <li>• Input resistance <math>\geq</math> Approx. 2 k<math>\Omega</math></li> <li>• Because the input resistance is as low as approx. 2 k<math>\Omega</math>, a large amount of current will flow during measurement. Never use the meter for measuring circuits or devices having a small current capacity. Never use the meter for measuring frequencies to ground as the earth leakage breaker may trip.</li> </ul>
50.00Hz		
500.0Hz		
5.000kHz		
50.00kHz		
100.0kHz		

## Capacitance

Range	Accuracy	Remarks
50.00nF	$\pm(5.0\%rdg+10dgt)$	<ul style="list-style-type: none"> <li>• Accuracy after canceling the indicated value by the relative function.</li> <li>• Auto range only</li> </ul>
500.0nF		
5.000 $\mu$ F		
50.00 $\mu$ F		
100.0 $\mu$ F		

## DCA

Range	Accuracy	Input Resistance	Remarks
400.0 $\mu$ A	$\pm(1.4\%rdg+3dgt)$	Approx. 100 $\Omega$	<ul style="list-style-type: none"> <li>• The input resistance excludes the fuse resistance.</li> </ul>
4000 $\mu$ A		Approx. 1 $\Omega$	
40.00mA			
400.0mA	$\pm(2.0\%rdg+3dgt)$	Approx. 0.01 $\Omega$	
4.000A			
15.00A			

## ACA

Range	Accuracy	Input Resistance	Remarks
400.0 $\mu$ A	$\pm(1.8\%rdg+6dgt)$	Approx. 100 $\Omega$	Accuracy guaranteed frequency range: 45 Hz~1 kHz Crest factor (CF) range: 3 max. Range: 5% to 100% of each range
4000 $\mu$ A		Approx. 1 $\Omega$	
40.00mA			
400.0mA	$\pm(2.4\%rdg+6dgt)$	Approx. 0.01 $\Omega$	
4.000A			
15.00A			

\* Maximum 20A can be measured if the measurement time is less than 10 seconds. (Take 10 minutes or longer intervals between measurements.)

\* Accurate measurement may not be possible in places near a transformer, large-current line, etc. where a strong magnetic field is present or near radio equipment, etc. that generates a strong electric field.

### **Accuracy calculation**

Example: DCV function

True value: 100 mV

Range accuracy: 400 mV range ...  $\pm(0.5\%rdg+2dgt)$

Error:  $\pm (100.0mV \times 0.5\% + 2dgt) = \pm 0.7mV$

Indicated value: 100.0mV  $\pm 0.7mV$  (in a range of 99.3 mV and 100.7 mV)

The product specifications described in this manual and its appearance are subject to change without notice for improvement or other reasons.



# **sanwa**®

## **三和電気計器株式会社**

本社=東京都千代田区外神田2-4-4・電波ビル

郵便番号=101-0021・電話=東京(03)3253-4871(代)

大阪営業所=大阪市浪速区恵美須西2-7-2

郵便番号=556-0003・電話=大阪(06)6631-7361(代)

**SANWA ELECTRIC INSTRUMENT CO.,LTD.**

Dempa Bldg., 4-4 Sotokanda2-Chome Chiyoda-Ku,Tokyo,Japan