



ESM-9995 96 x 96 DIN 1/4 Universal Input Profile Controller

- 100 program, 1000 step control
- Programmable relay functions per steps
- Universal process input (TC, RTD, mV $\frac{mV}{\text{---}}$, V $\frac{V}{\text{---}}$, mA $\frac{mA}{\text{---}}$)
- 6 different electric cut-out behaviour
- ON/OFF, P, PI, PD, PID reverse and direct control
- Motorized valve control with feedback
- Motorized valve control floating control
- Auto-Tuning and Self-Tuning (automatic calculations of PID parameters)
- Automatic / Manual operating modes
- Bumpless transfer ability
- Sensor Error detection
- Remote Set control
- Re-transmission (for process, SET values)
- Operating with Real Time Clock (RTC)
- 8 set point which is selected with digital inputs
- ModBus ASCII/RTU communication protocol

1.PREFACE	Sayfa 4
1.1 GENERAL SPECIFICATIONS	
1.2 ORDERING INFORMATION	
1.3 WARRANTY	
1.4 MAINTENANCE	
2.INSTALLATION	Sayfa 6
2.1 GENERAL DESCRIPTION	
2.2 DIMENSIONS	
2.3 PANEL CUT-OUT	
2.4 ENVIRONMENTAL RATINGS	
2.5 PANEL MOUNTING	
2.6 INSTALLATION FIXING CLAMP	
2.7 REMOVING FROM THE PANEL	
3.ELECTRICAL WIRINGS	Sayfa 11
3.1 TERMINAL LAYOUT AND CONNECTION INSTRUCTION	
3.2 ELECTRICAL WIRING DIAGRAM	
4.DEFINITION OF FRONT PANEL AND ACCESSING TO THE PARAMETERS	Sayfa 13
4.1 DEFINITION OF FRONT PANEL	
4.2 BUTTONS AND THEIRS FUNCTIONS	
4.3 ACCESS THE STEP SETTINGS PAGES	
4.4 ACCESS TO MENUS	
4.5 CHANGING THE PARAMETER VALUES	
5.PARAMETERS	Sayfa 18
5.1 OPERATOR PARAMETERS	
5.2 TECHNICIAN PARAMETERS	
6.ADJUSTMENT OF PROCESS SET VALUE	Sayfa 24
6.1. PARAMETRICALLY CHANGING PROCESS SET VALUE	
6.2. USING INPUT 0-20 mA	
6.3. USING DIGITAL INPUTS	
7. PROFILE PROGRAM	Sayfa 25
7.1 ADJUSTING THE PROFILE PROGRAM	
7.2 COPY PROFILE PROGRAM	
7.3 DELETE PROFILE PROGRAM	
7.4 DELETE STEP	
7.5 COPY STEP	
7.6 INSERT STEP	
7.7 RUNNING OF PROFILE PROGRAM	
8. MODBUS ADDRESSES	Sayfa 36
8.1 READ INPUT REGISTERS MODBUS ADDRESSES	
8.2 PROFILE PROGRAM MODBUS ADDRESSES	
8.3 PROFILE STEPS MODBUS ADDRESSES	
9. MOTORIZED VALVE CONTROL	Sayfa 39
10. PROFILE PROGRAM EXAMPLE	Sayfa 40
11. SPECIFICATION	Sayfa 41
12. OTHER INFORMATION	Sayfa 42

EU DECLARATION OF CONFORMITY

Manufacturer's Name : EMKO ELEKTRONIK A.S.
Manufacturer's Address : DOSAB, Karanfil Sk., No:6,
16369 Bursa, TURKEY

The manufacturer hereby declares that the product:

Product Name : Profile Controller Unit
Type Number : ESM-9995
Product Category : Electrical equipment for measurement, control and laboratory use

Conforms to the following directives :

2006 / 95 / EC The Low Voltage Directive

2004 / 108 / EC The Electromagnetic Compatibility Directive

has been designed and manufactured to the following specifications:

EN 61000-6-4:2007 EMC Generic Emission Standard for Industrial Environments

EN 61000-6-2:2005 EMC Generic Immunity Standard for Industrial Environments

EN 61010-1:2001 Safety Requirements for electrical equipment for measurement, control and laboratory use

When and Where Issued

02nd November 2010

Bursa-TURKEY

Authorized Signature

Name : Serpil YAKIN

Position : Quality Manager

1. Preface

ESM series process controllers are designed for measuring and controlling temperature and any process value. They can be used in many applications with their universal process input, multifunction control outputs, selectable alarm functions, serial communication unit and input/output modules.

Some application fields and applications which they are used are below:

<u>Application Fields</u>	<u>Applications</u>
Glass	Motorized valve control
Plastic	Profile Control
Petro-Chemistry	PID Process Control
Textile	Heater Failure detection
Automotive	
Machine production industries	

1.1 General Specifications

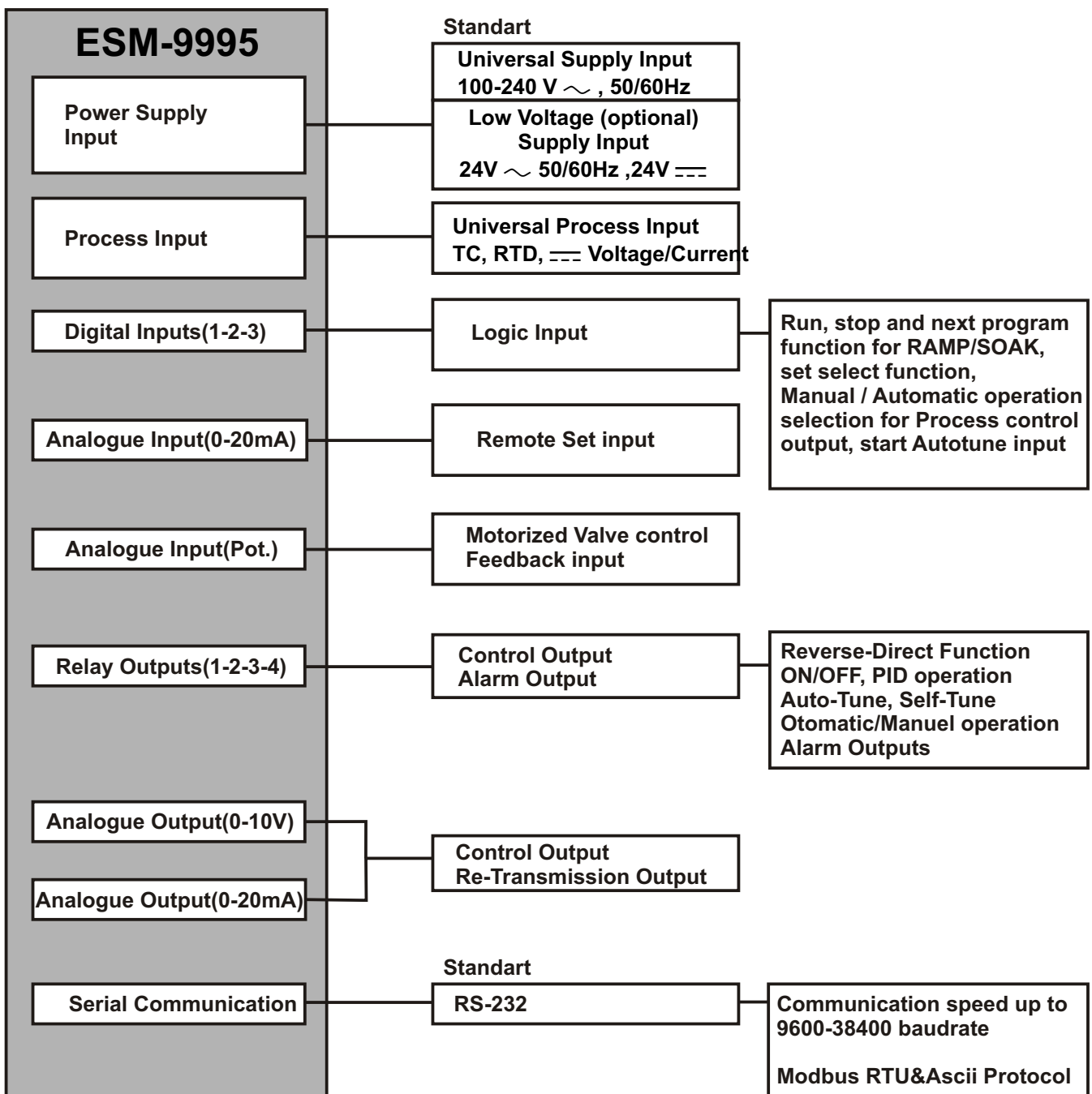

1.2 Ordering Information

ESM-9995 (96x96 1/4 DIN)	A	BC	D	E	/	FG	HI	/	U	V	W	Z
		20	1	1	/			/	0	0	0	0

A Power Supply
1 100-240V ~ (-%15;+%10) 50/60Hz
2 24 V ~ (-%15;+%10) 50/60Hz 24V === (-%15;+%10)

BC Input type	Scale
20 Configurable(Table-1)	Table-1

D Serial Communication
1 RS-232

E Output-1
1 4*Relay Output (5A@ 250V~ Resistive Load)

FG Analogue Output-1
04 0/4...20mA=== Current Output
05 0...10V=== Voltage Output

HI Analogue Output-2
04 0/4...20mA=== Current Output
05 0...10V=== Voltage Output

All order information of ESM-9995 are given on the table at left. User may form appropriate device configuration from information and codes that at the table and convert it to the ordering codes.

Firstly, supply voltage then input/output types and other specifications must be determined. Please fill the order code blanks according to your needs.

Please contact us, if your needs are out of the standards.

Table-1

BC	Input Type(TC)	Scale(°C)	Scale(°F)
21	L ,Fe Const DIN43710	-100°C,850°C	-148°F,1562°F
22	L ,Fe Const DIN43710	-100.0°C,850.0°C	-148.0°F,999.9°F
23	J ,Fe CuNi IEC584.1(ITS90)	-200°C,900°C	-328°F,1652°F
24	J ,Fe CuNi IEC584.1(ITS90)	-199.9°C,900.0°C	-199.9°F,999.9°F
25	K ,NiCr Ni IEC584.1(ITS90)	-200°C,1300°C	-328°F,2372°F
26	K ,NiCr Ni IEC584.1(ITS90)	-199.9°C,999.9°C	-199.9°F,999.9°F
27	R ,Pt13%Rh Pt IEC584.1(ITS90)	0°C,1700°C	32°F,3092°F
28	S ,Pt10%Rh Pt IEC584.1(ITS90)	0°C,1700°C	32°F,3092°F
29	T ,Cu CuNi IEC584.1(ITS90)	-200°C,400°C	-328°F,752°F
30	T ,Cu CuNi IEC584.1(ITS90)	-199.9°C,400.0°C	-199.9°F,752.0°F
31	B ,Pt30%Rh Pt6%Rh IEC584.1(ITS90)	44°C,1800°C	111°F,3272°F
32	B ,Pt30%Rh Pt6%Rh IEC584.1(ITS90)	44.0°C,999.9°C	111.0°F,999.9°F
33	E ,NiCr CuNi IEC584.1(ITS90)	-150°C,700°C	-238°F,1292°F
34	E ,NiCr CuNi IEC584.1(ITS90)	-150.0°C,700.0°C	-199.9°F,999.9°F
35	N ,Microsil Nisil IEC584.1(ITS90)	-200°C,1300°C	-328°F,2372°F
36	N ,Microsil Nisil IEC584.1(ITS90)	-199.9°C,999.9°C	-199.9°F,999.9°F
37	C , (ITS90)	0°C,2300°C	32°F,3261°F
38	C , (ITS90)	0.0°C,999.9°C	32.0°F,999.9°F

BC	Input Type(RTD)	Scale(°C)	Scale(°F)
39	PT 100 , IEC751(ITS90)	-200°C,650°C	-328°F,1202°F
40	PT 100 , IEC751(ITS90)	-199.9°C,650.0°C	-199.9°F,999.9°F

BC	Input Type(=== Voltage and Current)	Scale
41	0...50 mV ===	-1999,9999
42	0...5 V ===	-1999,9999
43	0...10 V ===	-1999,9999
44	0...20 mA ===	-1999,9999
45	4...20 mA ===	-1999,9999

1.3 Warranty

EMKO Elektronik warrants that the equipment delivered is free from defects in material and workmanship. This warranty is provided for a period of two years. The warranty period starts from the delivery date. This warranty is in force if duty and responsibilities which are determined in warranty document and instruction manual performs by the customer completely.

1.4 Maintenance

Repairs should only be performed by trained and specialized personnel. Cut power of the device before accessing internal parts.

Do not clean the case with hydrocarbon-based solvents (Petrol, Trichlorethylene etc.). Use of these solvents can reduce the mechanical reliability of the device. Use a cloth dampened in ethyl alcohol or water to clean the external plastic case.

2. Installation



Before beginning installation of this product, please read the instruction manual and warnings below carefully.

In package ,

- One piece unit
- Two pieces mounting clamps
- One piece instruction manual

A visual inspection of this product for possible damage occurred during shipment is recommended before installation. It is your responsibility to ensure that qualified mechanical and electrical technicians install this product.

If there is danger of serious accident resulting from a failure or defect in this unit, power off the system and separate the electrical connection of the device from the system.

The unit is normally supplied without a power switch or a fuse. Use power switch and fuse as required.

Be sure to use the rated power supply voltage to protect the unit against damage and to prevent failure.

Keep the power off until all of the wiring is completed so that electric shock and trouble with the unit can be prevented.

Never attempt to disassemble, modify or repair this unit. Tampering with the unit may results in malfunction, electric shock or fire.

Do not use the unit in combustible or explosive gaseous atmospheres.

During the equipment is putted in hole on the metal panel while mechanical installation some metal burrs can cause injury on hands, you must be careful.

Montage of the product on a system must be done with it's fixing clamps. Do not do the montage of the device with inappropriate fixing clamp. Be sure that device will not fall while doing the montage.

It is your responsibility if this equipment is used in a manner not specified in this instruction manual.

2.1 General Description

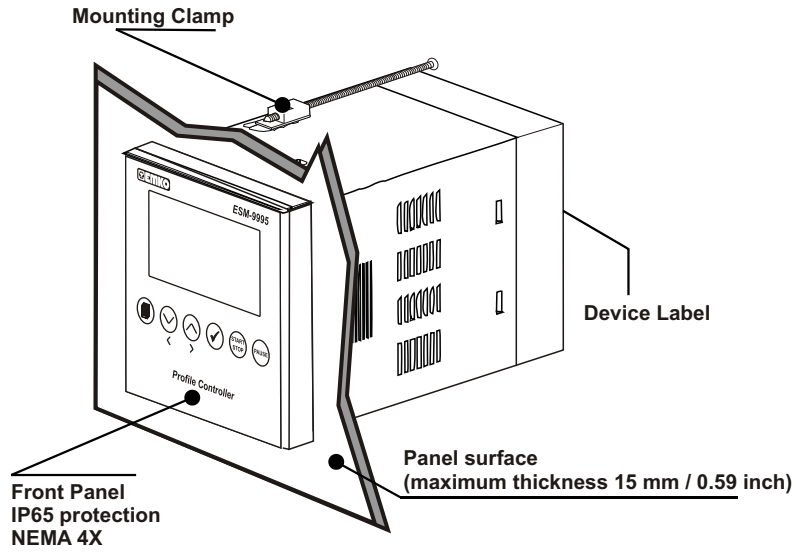

2.2 Dimensions

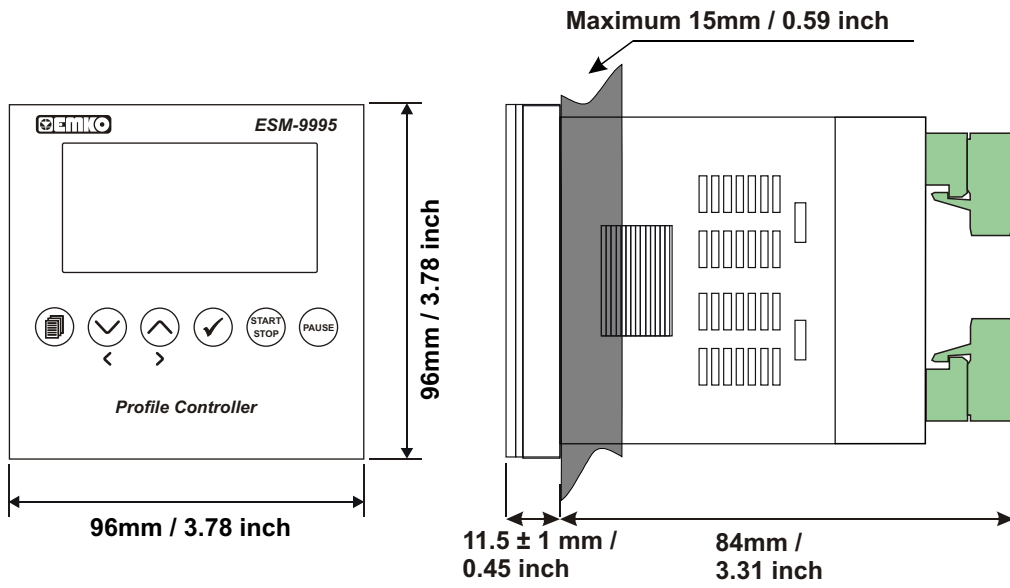

2.3 Panel Cut-out

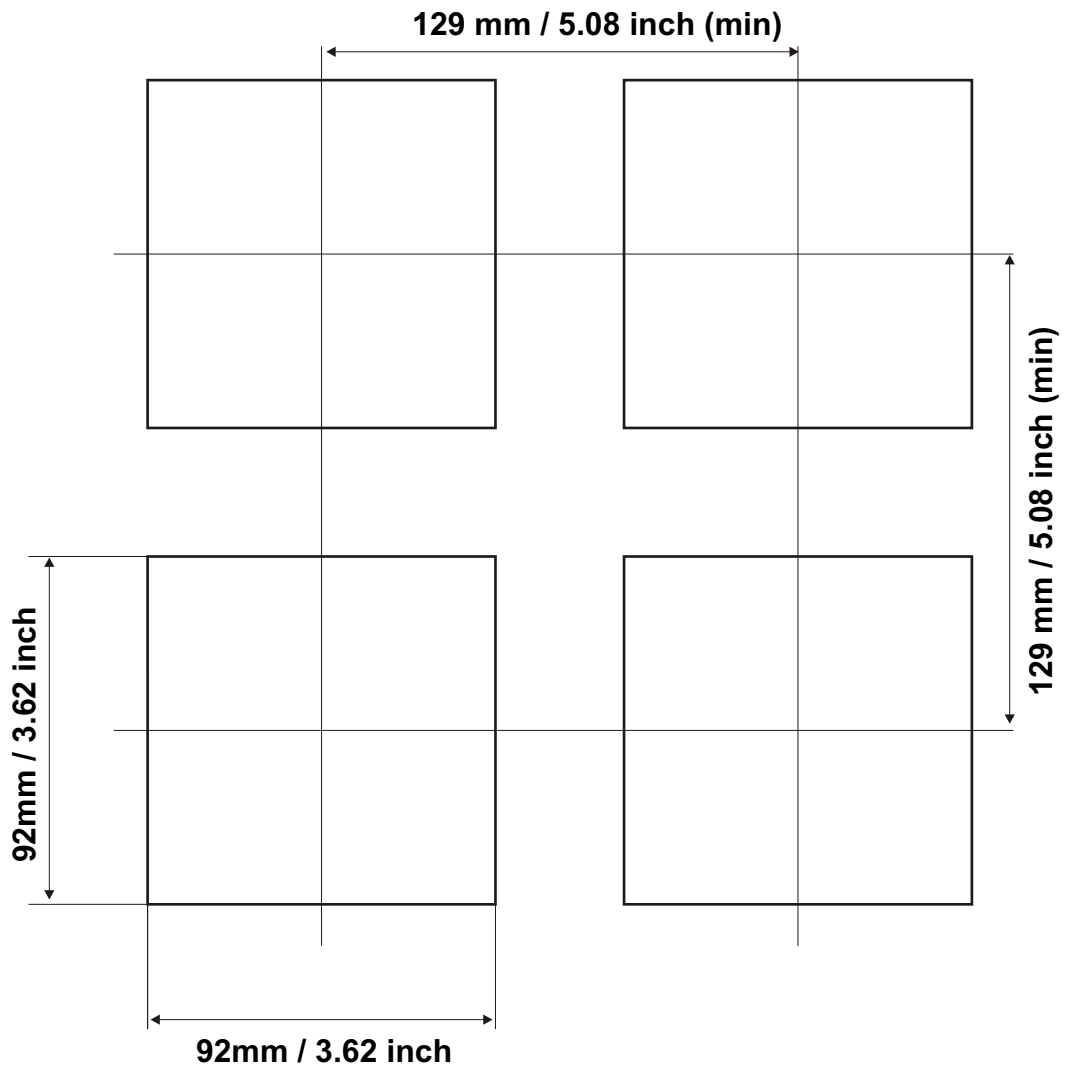

2.4 Environmental Ratings

Operating Conditions



Operating Temperature : 0 to 50 °C



Max. Operating Humidity : 90% Rh (non-condensing)



Altitude : Up to 2000m.



Forbidden Conditions:

Corrosive atmosphere

Explosive atmosphere

Home applications (The unit is only for industrial applications)

2.5 Panel Mounting

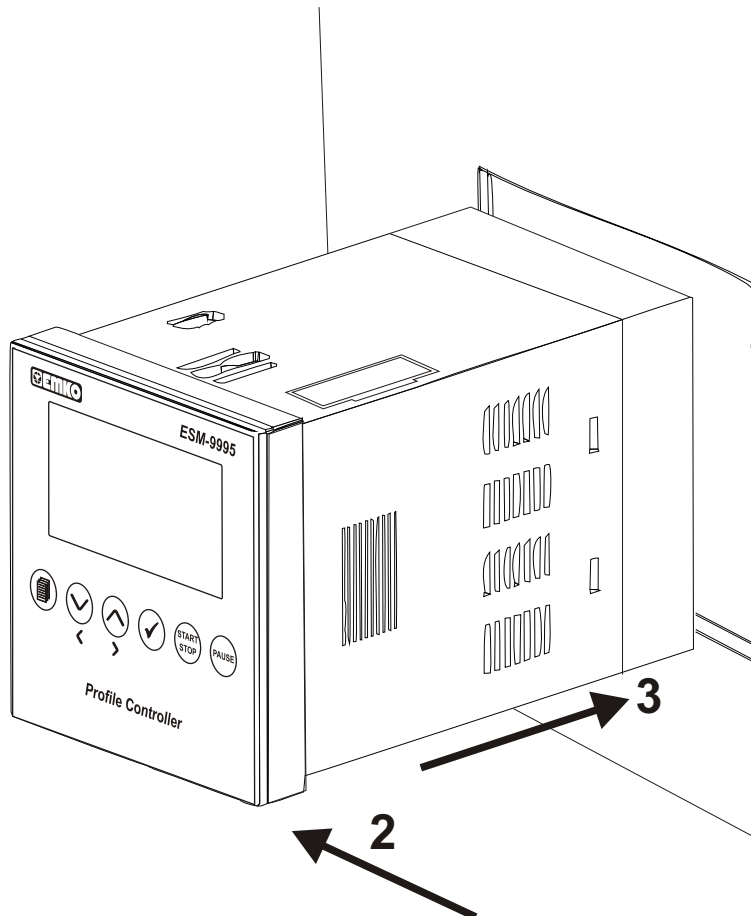

1-Before mounting the device in your panel, make sure that the cut-out is of the right size.

2-Check front panel gasket position

3-Insert the device through the cut-out. If the mounting clamps are on the unit, put out them before inserting the unit to the panel.



During installation into a metal panel, care should be taken to avoid injury from metal burrs which might be present. The equipment can loosen from vibration and become dislodged if installation parts are not properly tightened. These precautions for the safety of the person who does the panel mounting.

2.6 Installation Fixing Clamp

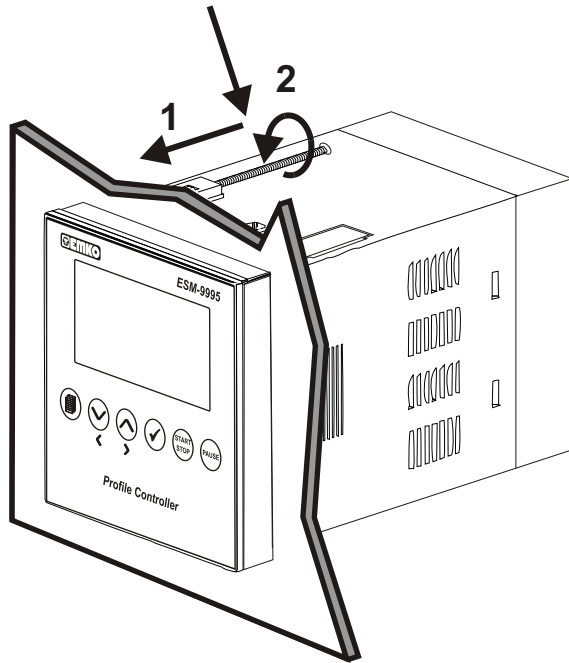

The unit is designed for panel mounting.

1-Insert the unit in the panel cut-out from the front side.

2- Insert the mounting clamps to the holes that located top and bottom sides of device and screw up the fixing screws until the unit completely immobile within the panel



Montage of the unit to a system must be done with it's own fixing clamps. Do not do the montage of the device with inappropriate fixing clamps. Be sure that device will not fall while doing the montage.

2.7 Removing from the Panel



Before starting to remove the unit from panel, power off the unit and the related system.

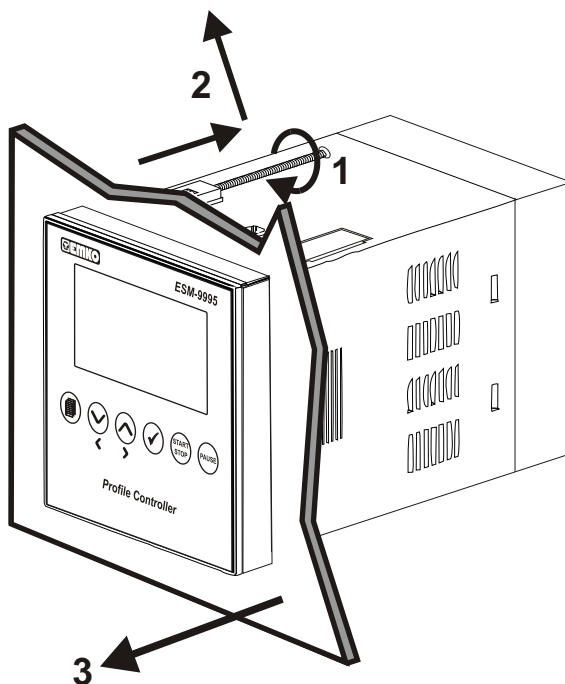

1-Loosen the screws.

2-Pull mounting clamps from top and bottom fixing sockets.

3-Pull the unit through the front side of the panel

3. Electrical Wirings



You must ensure that the device is correctly configured for your application. Incorrect configuration could result in damage to the process being controlled, and/or personal injury. It is your responsibility, as the installer, to ensure that the configuration is correct.

Device parameters has factory default values. These parameters must be set according to the system's needs.



Only qualified personnel and technicians should work on this equipment. This equipment contains internal circuits with voltage dangerous to human life. There is severe danger for human life in the case of unauthorized intervention.



Be sure to use the rated power supply voltage to protect the unit against damage and to prevent failure.



Keep the power off until all of the wiring is completed so that electric shock and trouble with the unit can be prevented.

3.1 Terminal Layout and Connection Instructions

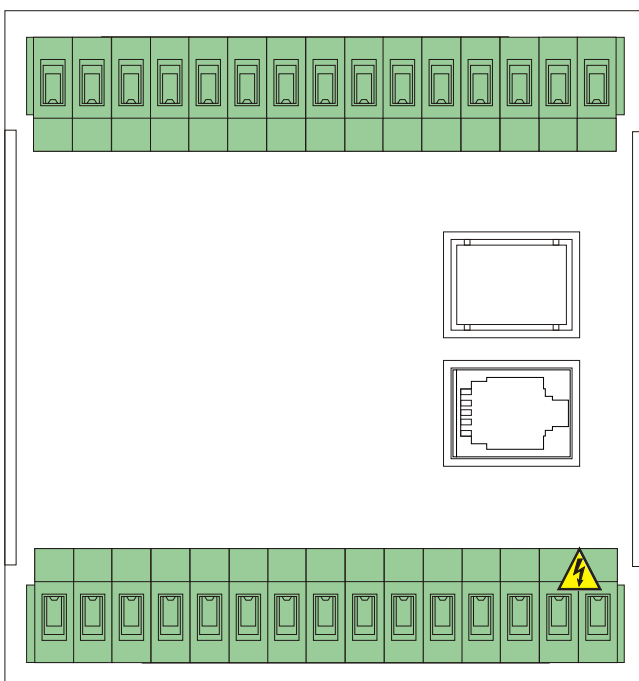

Max. 2.5mm / 0.098 inch
Wire Size:
18AWG/1mm²
Solid /Stranded

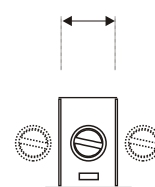

Torque
0,5Nm



Screw driver
0,8 x3mm



3.2 Electrical Wiring Diagram



Electrical wiring of the device must be the same as 'Electrical Wiring Diagram' below to prevent damage to the process being controlled and personnel injury.

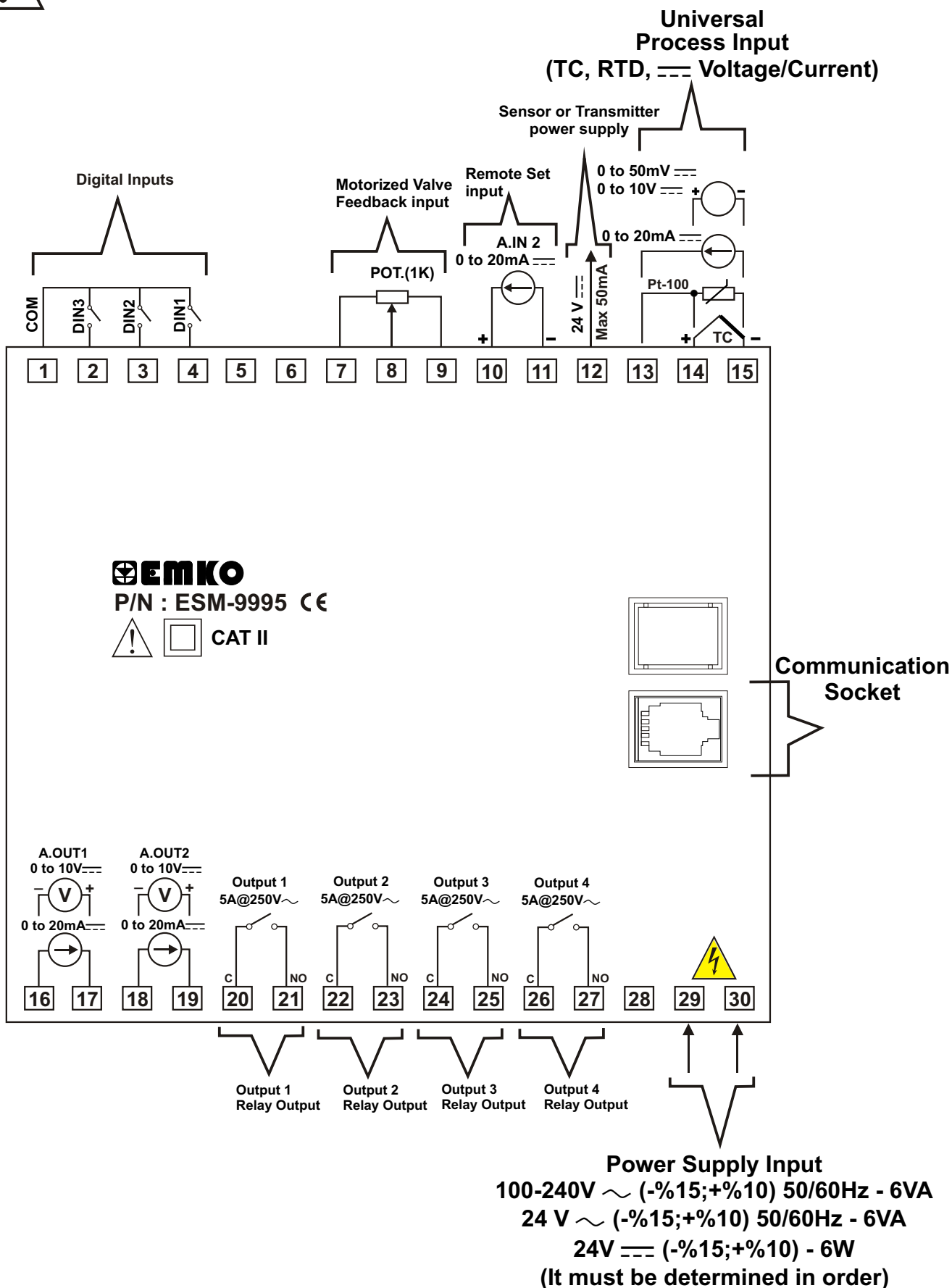

4. Definition of Front Panel and Accessing to the Parameters

4.1 Definition of Front Panel

MAIN OPERATION SCREEN VIEW

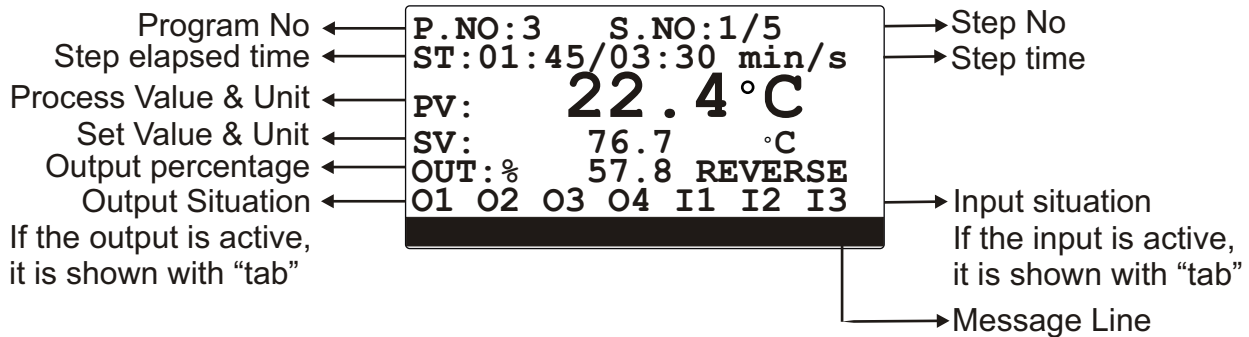

GRAPHIC PAGE VIEW

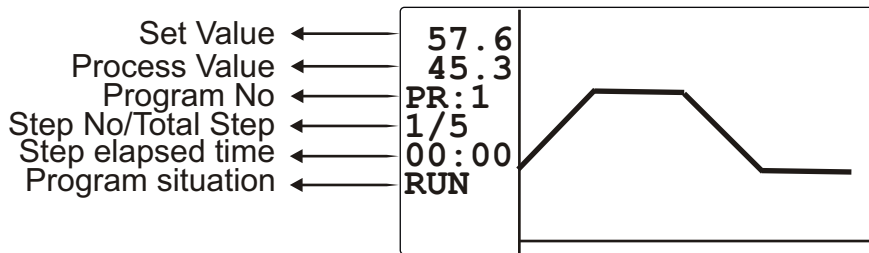

INFORMATION PAGE VIEW

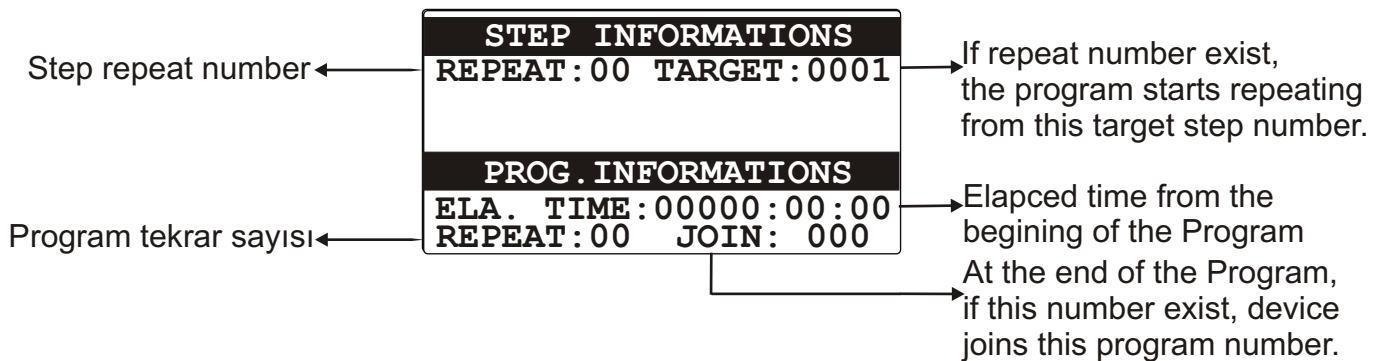

4.2. Buttons and Theirs Functions

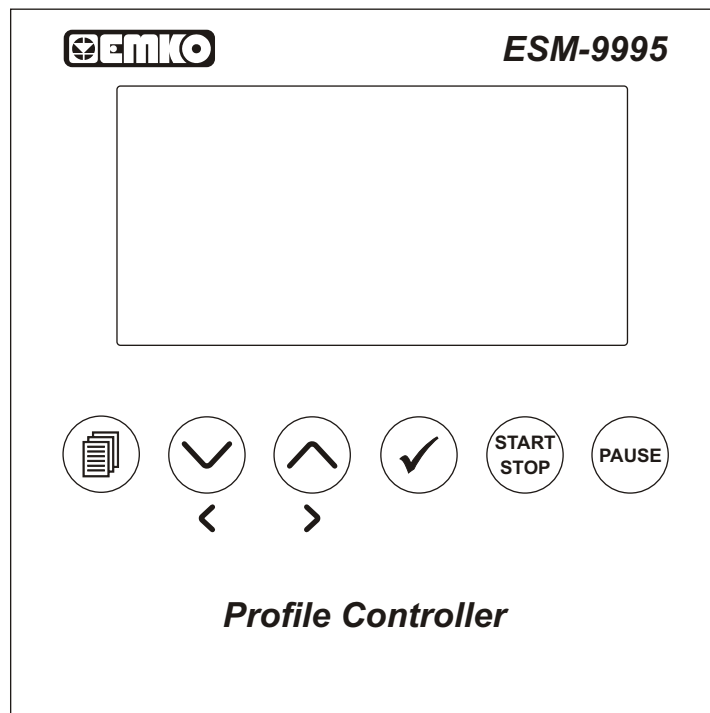

Menu Button is used to go back to upper menu.



Decrement Button is used to decrease value of parameters.



Increment Button is used to increase value of parameters.



Enter Button is used to confirm parameter changings and also using this button, any alarm can be suspended.



START/STOP Button is used to start or stop a profile program.



PAUSE Button is used to pause a profile program.

4.3. Access the Step Settings Pages

OPERATING PAGE VIEWS WHEN DEVICE IS SELECTED AS PROFILE CONTROL

EMKO ESM-9995
 P.NO:3 S.NO:1/5
 ST:01:45/03:30 min/s
 PV: **22.4 °C**
 SV: 76.7 °C
 OUT:% 57.8 REVERSE
 01 02 03 04 I1 I2 I3

[Menu] [Down] [Up] [Check] [START STOP] [PAUSE]
 < >

Profile Controller

(Main Working Page)

STEP INFORMATIONS
 REPEAT:00 TARGET:0001
STEP INFORMATIONS
 REPEAT:00 TARGET:0000
PROG. INFORMATIONS
 ELA.TIME:0000:00:00
 REPEAT:00 JOIN:000

(Information Page)

PNO:1 FNC:EDIT
 SNO:4
 SSV:0.0 °C
 STG:00.00
 SRP:0
 STS:1
 SEV:0/0/0/0/0/0

(Step Settings Page)

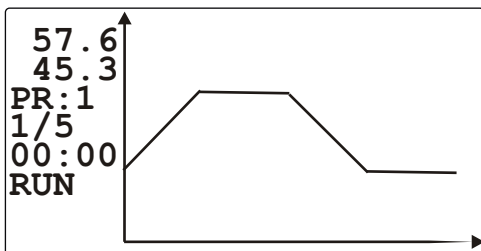

(Graphical Page)

PNO:1 FNC:EDIT
 PRC:0
 PSJ:OFF
 SJD:OFF
 SDT:OFF
 PDT:OFF

(Program Settings Page)

4.4. Access to Menus

P.NO:3 S.NO:1/5
 ST:01:45/03:30 min/s
 PV: **22.4 °C**
 SV: 76.7 °C
 OUT:% 57.8 REVERSE
 01 02 03 04 I1 I2 I3

Hold pressing for 1 second

OPERATOR SECTION

OPERATOR SECTION
OPERATOR PARAMETERS

Page 17/5.1

TECHNICIAN SECTION

CALIBRATION SECTION

TECHNICIAN SECTION
DEVICE SETTING PAGE

Page 18/5.2.1

TECHNICIAN SECTION
UNIVERSAL INPUT PAGE

Page 18/5.2.2

TECHNICIAN SECTION
REMOTE SET PAGE

Page 19/5.2.3

TECHNICIAN SECTION
MOTORIZED VALVE PAGE

Sayfa 19/5.2.4

TECHNICIAN SECTION
DIGITAL INPUT X PAGE

Page 19/5.2.5
Page 19/5.2.6
Page 19/5.2.7

TECHNICIAN SECTION
PID SETTING PAGE

Page 19/5.2.8

TECHNICIAN SECTION
ANALOG OUTPUT X PAGE

Page 20/5.2.9
Page 20/5.2.10

TECHNICIAN SECTION
RELAY OUTPUT X PAGE

Page 20/5.2.11
Page 21/5.2.12
Page 21/5.2.13
Page 22/5.2.14

TECHNICIAN SECTION
SERIAL COMM. PAGE

Page 22/5.2.15

TECHNICIAN SECTION
DATE SETTING PAGE

Page 22/5.2.16

TECHNICIAN SECTION
PASSWORD PAGE

Page 22/5.2.17

TECHNICIAN SECTION
OPERATOR PARAMETERS

Page 17/5.1

4.5. Changing the Parameter values

```

P.NO:1    S.NO:1/5
ST:01:45/03:30 min/s
PV:      22.4 °C
SV:      76.7 °C
OUT:%    57.8 REVERSE
O1 O2 O3 O4 I1 I2 I3
  
```

MENU button is used to pass through sections.



```

OPERATOR SECTION
  
```

ENTER button is used to enter Parameter Pages.



```

OPERATOR SECTION
OPERATOR PARAMETERS
  
```

ENTER is used to access to parameters.



```

OPERATOR SECTION
OPERATOR PARAMETERS
1 OPERATING PROG.NO
  1
  
```

```

OPERATOR SECTION
OPERATOR PARAMETERS
1 OPERATING PROG.NO
  3
  
```

ENTER button is used to save the parameter and to pass another parameter.



```

OPERATOR SECTION
OPERATOR PARAMETERS
7 TUNE SELECTION
  AUTUNE
  
```

MENU buttons is used to return back to the previous menu.menu.



```

OPERATOR SECTION
OPERATOR PARAMETERS
  
```

MENU buttons is used to return back to the previous menu.



```

P.NO:1    S.NO:1/5
ST:01:45/03:30 min/s
PV:      22.4 °C
SV:      76.7 °C
OUT:%    57.8 REVERSE
O1 O2 O3 O4 I1 I2 I3
  
```



UP/DOWN buttons is used to change parameter's values.

5. Parameters

5.1. Operator Parameters

OPERATOR PARAMETERS		Min	Max	Default	Unit	Mdb.Add.
A01 OPERATING PR. NO	Operating Program number	1	100	1		40001
A02 PROCESS SETVALUE	Process Set value	-9999	9999	0	°C	40002
A03 ALARM 1 SETVALUE	Alarm 1 Set value	-9999	9999	0	°C	40003
A04 ALARM 2 SETVALUE	Alarm 2 Set value	-9999	9999	0	°C	40004
A05 ALARM 3 SETVALUE	Alarm 3 Set value	-9999	9999	0	°C	40005
A06 ALARM 4 SETVALUE	Alarm 4 Set value	-9999	9999	200	°C	40006
A07 TUNE SELECTION	Tune type sel. (NOTUNE,AUTUNE,SELFTU,ASTUNE)	NOTUNE	ASTUNE	NOTUNE		40007
A08 AUTOMTC. TUNE SL	Otomatik tune selection (YES,NO)	NO	YES	NO		40008
A09 OPERAT. FORM SEL	Operating form selection (AUTO.,MANUEL)	AUTO.	MANUAL	AUTO.		40009
A10 BUMPLESS TRAN.SL	Bumpless Transfer selection (YES,NO)	NO	YES	NO		40010
A11 ALARM LATCHCANCL	Alarm Latch Cancel (YES,NO)	NO	YES	NO		40011
A12 SLCTABLE 1.SET	Selectable Set 1 value	-9999	9999	0	°C	40012
A13 SLCTABLE 2.SET	Selectable Set 2 value	-9999	9999	0	°C	40013
A14 SLCTABLE 3.SET	Selectable Set 3 value	-9999	9999	0	°C	40014
A15 SLCTABLE 4.SET	Selectable Set 4 value	-9999	9999	0	°C	40015
A16 SLCTABLE 5.SET	Selectable Set 5 value	-9999	9999	0	°C	40016
A17 SLCTABLE 6.SET	Selectable Set 6 value	-9999	9999	0	°C	40017
A18 SLCTABLE 7.SET	Selectable Set 7 value	-9999	9999	0	°C	40018
A19 SLCTABLE 8.SET	Selectable Set 8 value	-9999	9999	0	°C	40019
A20 MOTORIZD CONTROL	Motorized Valve Control (NO,REVERS,DIRECT)	NO	YES	NO		40020
A21 PWR.FAIL.BEHAVIO	Power Fail behaviour	1	6	1		40021
A22 PWR.FAIL.PERCENT	Power Fail Percent	0	100	0	%	40022
A23 MSG. DISP. TIME	Message display time	1	10	0	Sec.	40023
A24 PROFILE TYPE	Profile Type	0	2	0		40024
A25 COOLING ACT.TIME	Cooling Output Activation Time	OFF	60	0	Sec.	40025

Note-1: A21-PWR.FAIL.BEHAVIO parameter operating types:

- 1- Program is stopped.
- 2- Program continues remaining step and time.
- 3- Program continues from the beginning of the step.
- 4- Program wait for start approval on remaining step and time. Control output is off.
- 5- Program returns the beginning of the step and wait for approval. Control output is off.
- 6- If the difference between process value(before power fail) and process value(after power on) is lower than PWR.FAIL.PERCENT parameter, then process continues its remainig position, otherwise operates 5. entry item.

Note-2: A01 parameter is shown, if the device is configured as profile control.

Note-3: A12, A13, A14, A15, A16, A17, A18 and A19 parameters are shown, if the device is configured as process control.

Note-4: If A25 parameter is *OFF*, cooling outputs are always off.

Note-5: Selectable set value depends on active digital inputs that are selected as **SETSEL**. (Go to Page 23/6.3)

NOTUNE : No Tune

AUTUNE : Auto tune (Limit Cycle Tune)

SELFTU : Self Tune

ASTUNE : Self and Autotune

REVERS : Heating Control

DIRECT : Cooling Control

BUMPLESS: If has been selected as **NO**, when device operating mode is chanced to Manuel Mode from Automatic Mode, old process value isn't used in the new mode.

If has been selected as **YES**, when device operating mod is chanced to Manuel Mode from Automatic Mode, old process value is used in the new mode.

Note-6: Tunning works only if device type is process control.

5.2. Technician Parameters

If the device is configured as Profile Control;

5.2.1. DEVICE SETTING PAGE		Min	Max	Default	Unit	Mdb.Add
B01 OPERATING MODE	Device Operating Type <small>(PROCSS,PROFIL)</small>	PROCSS	PROFIL	PROFIL		51856
B02 MAX STEP NUMBER	Maximum Step Number	1	1000	20		51857
B03 MAX PROGRAM NUMB	Maximum Program Number	1	1000	36		51858
B04 STEP TIME UNIT	Step time unit <small>(Min/s,H/min)</small>	Min/s	Min	Min/s		51859
B05 PR.STEP RAMP TYP	Program Step Ramp Type <small>(TIME,GRADI.)</small>	TIME	GRADI.	TIME		51860
B06 PR.TOLERAN. BAND	Program Tolerance Band	-200	650	10		51861

If the device is configured as Process Control;

5.2.1 DEVICE SETTING PAGE		Min	Max	Default	Unit	Mdb.Add
B01 OPERATING MODE	Device Operating Type <small>(PROCSS,PROFIL)</small>	PROCSS	PROFIL	PROCSS		51856

5.2.2. UNIVERSAL INPUT PAGE		Min	Max	Default	Unit	Mdb.Add
C01 INPUT TYPE	Input Type <small>(TC,RTD,V/I)</small>	TC	V/I	TC		51876
C02 TC TYPE	Termocouple type <small>(T,Tpo,B,Bpo,C,Cpo,E,Epo,N,Npo)</small>	L	N po	J		51877
C03 TC COLDJUNC.COMP	Cold junction compensansation <small>(YES,NO)</small>	NO	YES	YES		51878
C04 RTD TYPE	RTD type	0	1	0		51879
C05 V/I TYPE	Voltage/Current type	0-50mV	4-20mA	0-50mV		51880
C06 V/I DEC. DOT POS	Voltage/Current Decimal Point Pos.	NO P.	0.000	NO P.		51881
C07 V/I MULT. COEFF	Voltage/Current Coefficient	1000	9999	1000		51882
C08 V/I CALIBR. TYPE	Voltage/Current Cal. Type <small>(FIXED,DUALP,16P)</small>	FIXED	16 P.	FIXED		51883
C09 V/I S.D.P. CAL.MN	Voltage/Current 2 point calibration min	-1999	9999	0		51884
C10 V/I S.D.P. CAL.MX	Voltage/Current 2 point calibration max	-1999	9999	0		51885
C11 V/I 16.PT.CAL.1PT	Voltage/Current 16 point calibration 1	-1999	9999	0		51886
C12 V/I 16.PT.CAL.2PT	Voltage/Current 16 point calibration 2	-1999	9999	0		51887
C13 V/I 16.PT.CAL.3PT	Voltage/Current 16 point calibration 3	-1999	9999	0		51888
C14 V/I 16.PT.CAL.4PT	Voltage/Current 16 point calibration 4	-1999	9999	0		51879
C15 V/I 16.PT.CAL.5PT	Voltage/Current 16 point calibration 5	-1999	9999	0		51890
C16 V/I 16.PT.CAL.6PT	Voltage/Current 16 point calibration 6	-1999	9999	0		51891
C17 V/I 16.PT.CAL.7PT	Voltage/Current 16 point calibration 7	-1999	9999	0		51892
C18 V/I 16.PT.CAL.8PT	Voltage/Current 16 point calibration 8	-1999	9999	0		51893
C19 V/I 16.PT.CAL.9PT	Voltage/Current 16 point calibration 9	-1999	9999	0		51894
C20 V/I 16.PT.CAL.10P	Voltage/Current 16 point calibration 10	-1999	9999	0		51895
C21 V/I 16.PT.CAL.11P	Voltage/Current 16 point calibration 11	-1999	9999	0		51896
C22 V/I 16.PT.CAL.12P	Voltage/Current 16 point calibration 12	-1999	9999	0		51897
C23 V/I 16.PT.CAL.13P	Voltage/Current 16 point calibration 13	-1999	9999	0		51898
C24 V/I 16.PT.CAL.14P	Voltage/Current 16 point calibration 14	-1999	9999	0		51899
C25 V/I 16.PT.CAL.15P	Voltage/Current 16 point calibration 15	-1999	9999	0		51900
C26 V/I 16.PT.CAL.16P	Voltage/Current 16 point calibration 16	-1999	9999	0		51901
C27 PRO.LOW PNT ADJ	Process Low Point Adjustment	-1999	9999	0		51902
C28 PRO.HIGH PNT ADJ.	Process High Point Adjustment	-1999	9999	0		51903
C29 UNIT SELECTION	Unit Selection	°C	°F	°C		51904
C30 OPER. SCALE MIN	Operation Scale minimum	-1999	9999	0		51905
C31 OPER. SCALE MAX	Operation Scale maximum	-1999	9999	900		51906
C32 PRO.DIS.OFST.	Process Display Offset	-9999	9999	0		51907
C33 FILTER TIME	Filter time	0.0	999.9	0	Sec.	51908

FIXED :Fixed point calibration

DUALP :Dual point calibration

16P :16 point calibration

GRADI :Gradient (See the Page 34)

5.2.3. REMOTE SET PAGE		Min	Max	Default	Unit	Mdb.Add.
D01 REMOTE SET SELCT	Remote Set Selection	OFF	ON	OFF		51914
D02 INPUT TYPES	Input Type <small>(0-20mA,4-20mA)</small>	0-20mA	4-20mA	0-20mA		51915
D03 CALIBR. TYPE	Calibration Type <small>(FIXED,DUALP)</small>	FIXED	DUALP	FIXED		51916
D04 DUAL PO. CAL MIN	2 point calibration min	-1999	9999	0		51917
D05 DUAL PO. CAL MAX	2 point calibration max	-1999	9999	0		51918

5.2.4. MOTORIZED VALVE PAGE		Min	Max	Default	Unit	Mdb.Add.
E01 FEEDBACK CONTROL	Feedback Control <small>(FLOAT,FBACK)</small>	FLOAT	FBACK	FLOAT		51924
E02 BOUNDL. MOV.TIME	Boundary limit moving time	5	600	5	Sec.	51925
E03 VALVE DEAD BAND	Valve Dead Band	1	5.0	1.0	%	51926

5.2.5. DIGITAL INPUT 1 PAGE		Min	Max	Default	Unit	Mdb.Add.
F01 FUNCTION SELECT	Function Sel. <small>(NONE,MA,AUT,A.TUNE,PR,SS,PR.HOL,AL,LAT,NEXTPR,DOOR,SETSEL)</small>	NONE	SETSEL	NONE		51937

5.2.6. DIGITAL INPUT 2 PAGE		Min	Max	Default	Unit	Mdb.Add.
G01 FUNCTION SELECT	Function Sel. <small>(NONE,MA,AUT,A.TUNE,PR,SS,PR.HOL,AL,LAT,NEXTPR,DOOR,SETSEL)</small>	NONE	SETSEL	NONE		51950

5.2.7. DIGITAL INPUT 3 PAGE		Min	Max	Default	Unit	Mdb.Add.
H01 FUNCTION SELECT	Function Sel. <small>(NONE,MA,AUT,A.TUNE,PR,SS,PR.HOL,AL,LAT,NEXTPR,DOOR,SETSEL)</small>	NONE	SETSEL	NONE		51963

5.2.8. PID SETTING PAGE		Min	Max	Default	Unit	Mdb.Add.
I01 REV.PROPOR. BAND	Reverse Proportional Band	0.0	999.9	5.0		51976
I02 REV.INTEGRAL T.	Reverse Integral Time	0	3600	0	Sec.	51977
I03 REV.DERIVATI.T.	Reverse Derivative Time	0.0	9999	0	Sec.	51978
I04 REV.CON.PERI.T.	Reverse Control Period Time	1	150	10	Sec.	51979
I05 REV.MIN C.OUTT.	Reverse Min. Control Output Time	0.0	15.0	0.0	Sec.	51980
I06 REV.MIN CN.OUTPT	Reverse Min. Control Output	0.0	100.0	0.0	%	51981
I07 REV.MAX CN.OUTPT	Reverse Max. Control Output	0.0	100.0	100.0	%	51982
I08 DIR.PRO.BANDCOEF	Direct Proportional Band Coefficient	0	1000	100		51983
I09 DIR.PROPOR. BAND	Direct Proportional Band	0.0	999.9	100		51984
I10 DIR.INTEGRAL T.	Direct Integral Time	0	3600	5.0	Sec.	51985
I11 DIR.DERIVATI.T.	Direct Derivative Time	0.0	9999	0	Sec.	51986
I12 DIR.CON.PERI.T.	Direct Control Period Time	1	150	10	Sec.	51987
I13 DIR.MIN C.OUTT.	Direct Min. Control Output Time	0.0	15.0	0.0	Sec.	51988
I14 DIR.MIN CN.OUTPT	Direct Min. Control Output	0.0	100.0	0.0	%	51989
I15 DIR.MAX CN.OUTPT	Direct Max. Control Output	0.0	100.0	100.0	%	51990
I16 ANTIRESET WINDUP	Antireset windup	OT.AR	9999	OT.AR	°C	51991
I17 SETVALUE OFFSET	Set offset value	-9999	9999	0	°C	51992
I18 PID OUTPUT OFFSET	PID output offset value	-100.0	100.0	0.0	%	51994
I19 OU.OF.REL.PIDSET	Output offset related on PID set	-100.0	100.0	0.0	%	51993
I20 PRO.VAL.STABIL.	Process value stabilization	0	9999	900		51995
I21 PROPR.BAND SHIFT	Proportional Band Shifting	-9999	9999	0		51996
I22 SENS.BRE.OUT VAL	Sensor Break Output Value	-100.0	100.0	0.0	%	51997

FLOAT : Float contact

FBACK : Feedback

MA.AUT : Manuel-Automatic mode changing

A.TUNE : Autotune parameter activating

PR.SS : Program Start/Stop

PR.HOL : Program Hold (Pause)

AL.LAT : Alarm latching

DOOR : When related digital input is **PASSIVE**, working program becomes **HOLD** status.

NEXTPR: Next program

SETSEL : See the Page 23

5.2.9. ANALOG OUTPUT 1 PAGE		Min	Max	Default	Unit	Mdb.Add.
J01 OUTPUT TYPE SEL.	Output Type Sel. (0-10V/0-20MA/2-10V/4-20MA)	0-20MA	2-10V	0-20MA		52003
J02 FUNCTION SELECT	Function Selection (OFF,REVERS,DIRECT,TETRAN)	REVERS	RETRAN	OFF		52004
J03 RETRAN. TYPE SEL	Retransfer Type Sel. (RTPROC,RTSET,RTERR)	RTPROC	RTSET	RTPROC		52005

5.2.10. ANALOG OUTPUT 2 PAGE		Min	Max	Default	Unit	Mdb.Add.
K01 OUTPUT TYPE SEL.	Output Type Sel. (0-10V/0-20MA/2-10V/4-20MA)	0-20MA	2-10V	0-20MA		52013
K02 FUNCTION SELECT	Function Selection (OFF,REVERS,DIRECT,TETRAN)	REVERS	RETRAN	OFF		52014
K03 RETRAN. TYPE SEL	Retransfer Type Sel. (RTPROC,RTSET,RTERR)	RTPROC	RTSET	RTPROC		52015

5.2.11. RELAY OUTPUT 1 PAGE		Min	Max	Default	Unit	Mdb.Add.
L01 FUNCTION SELECT	Function selection (REVERS,DIRECT,LLO,OUT)	REVERS	LO.OUT	REVERS		52023
L02 CONTROL ALGORIT	Control Algorithm (ONOFF,PID)	ONOFF	PID	PID		52024
L03 ON/OFF HYS.	ON/OFF Hysteresis	0	9999	0	°C	52025
L04 ON/OFF HYS FUNC.	ON/OFF Hysteresis Function	0	1	0		52026
L05 ON/OFF ON DLY TI	ON/OFF On Delay time	0	9999	0	Sec.	52027
L06 LOG.OUT.OPER.	Logic Output Oper. (EVENT,ALARM,MA,AUT) (SENBRK,OV.RNG,PROEND,GENE)	EVENT	PROEND	PROEND		52028
L07 REL. STEP EVENT	Related Step Event	A	D	A		52029
L08 ALARM NUMBER	Alarm Number	1	4	1		52030
L09 AL.1 TYPE	Alarm-1 type (HIGH,LOW,D.HIGH,D.LOW,D.BAND,D.RANG)	HIGH	D.RANG	HIGH		52031
L10 AL.1 HYS	Alarm-1 Hysteresis	0	9999	0	°C	52032
L11 AL.1 ON DELAY T.	Alarm-1 On Delay time	0	9999	0	Sec.	52033
L12 AL.1 OFF DELAY T.	Alarm-1 Off Delay time	0	9999	0	Sec.	52034
L13 AL.2 TYPE	Alarm-2 type (HIGH,LOW,D.HIGH,D.LOW,D.BAND,D.RANG)	HIGH	D.RANG	HIGH		52035
L14 AL.2 HYS	Alarm-2 Hysteresis	0	9999	0	°C	52036
L15 AL.2 ON DELAY T.	Alarm-2 On Delay time	0	9999	0	Sec.	52037
L16 AL.2 OFF DELAY T.	Alarm-2 Off Delay time	0	9999	0	Sec.	52038
L17 AL.3 TYPE	Alarm-3 type (HIGH,LOW,D.HIGH,D.LOW,D.BAND,D.RANG)	HIGH	D.RANG	HIGH		52039
L18 AL.3 HYS	Alarm-3 Hysteresis	0	9999	0	°C	52040
L19 AL.3 ON DELAY T.	Alarm-3 On Delay time	0	9999	0	Sec.	52041
L20 AL.3 OFF DELAY T.	Alarm-3 Off Delay time	0	9999	0	Sec.	52042
L21 AL.4 TYPE	Alarm-4 type (HIGH,LOW,D.HIGH,D.LOW,D.BAND,D.RANG)	HIGH	D.RANG	HIGH		52043
L22 AL.4 HYS	Alarm-4 Hysteresis	0	9999	0	°C	52044
L23 AL.4 ON DELAY T.	Alarm-4 On Delay time	0	9999	0	Sec.	52045
L24 AL.4 OFF DELAY T.	Alarm-4 Off Delay time	0	9999	0	Sec.	52046

RETRAN : Retransmission

RTPROC : Retransmission of Process Value

RTSET : Retransmission of Set Value

RTERR : Retransmission of Error (|Set Value - Process Value|) Value

LO.OUT : Logic Out

EVENT : When an event defined in the profile program is active, related relay becomes ON.

ALARM : When anyone of selected alarm occurs, related relay becomes ON.

HIGH/LOW : When process value is higher/lower than alarm set value.

D.LOW/D.HIGH : When process set value is higher/lower as much as alarm set value.

D.BAND : When process value deviates from set value as much as alarm set value.

D.RANG : When process value is between (set value) ± (alarm set value) band.

MA.AUT : When Manuel Control Mode is selected, alarm occurs.

SENBRK : Sensor Break

OV.RNG : Process value is out range of **C30 OPER. SCALE MIN** and **C31 OPER. SCALA MAX** parameters.

PROEND : Program End

GENE : General Alarm: Tolerance Error, Sensor Break Error and Program End

Note-1: Tolerance Alarm is active if absolute value of (process value - set value) is greater than **B06 TOLERAN. BAND** parameter.

5.2.12. RELAY OUTPUT 2 PAGE		Min	Max	Default	Unit	Mdb.Add.
M01 FUNCTION SELECT	Function Selection <small>(REVERS,DIRECT,LLO.OUT)</small>	REVERS	LO.OUT	DIRECT		52047
M02 CONTROL ALGORIT	Control Algorithm <small>(ONOFF,PID)</small>	ONOFF	PID	PID		52048
M03 ON/OFF HYS.	ON/OFF Hysteresis	0	9999	0	°C	52049
M04 ON/OFF HYS FUNC.	ON/OFF Hysteresis Function	0	1	0		52050
M05 ON/OFF ON DLY TI	ON/OFF On delay time	0	9999	0	Sec.	52051
M06 LOG.OUT.OPER.	Logic Output Oper. <small>(EVENT,ALARM,MA.AUT) (SENBRK,OV.RNG,PROEND,GENERL)</small>	EVENT	PROEND	PROEND		52052
M07 REL. STEP EVENT	Related step event <small>(A,B,C,D)</small>	A	D	A		52053
M08 ALARM NUMBER	Alarm Number	1	4	1		52054
M09 AL.1 TYPE	Alarm-1 type <small>(HIGH,LOW,D.HIGH,D.LOW,D.BAND,D.RANG)</small>	HIGH	D.RANG	HIGH		52055
M10 AL.1 HYS	Alarm-1 Hysteresis	0	9999	0	°C	52056
M11 AL.1 ON DELAY T.	Alarm-1 On delay time	0	9999	0	Sec.	52057
M12 AL.1 OFF DELAY T.	Alarm-1 Off delay time	0	9999	0	Sec.	52058
M13 AL.2 TYPE	Alarm-2 type <small>(HIGH,LOW,D.HIGH,D.LOW,D.BAND,D.RANG)</small>	HIGH	D.RANG	HIGH		52059
M14 AL.2 HYS	Alarm-2 Hysteresis	0	9999	0	°C	52060
M15 AL.2 ON DELAY T.	Alarm-2 On delay time	0	9999	0	Sec.	52061
M16 AL.2 OFF DELAY T	Alarm-2 Off delay time	0	9999	0	Sec.	52062
M17 AL.3 TYPE	Alarm-3 type <small>(HIGH,LOW,D.HIGH,D.LOW,D.BAND,D.RANG)</small>	HIGH	D.RANG	HIGH		52063
M18 AL.3 HYS	Alarm-3 Hysteresis	0	9999	0	°C	52064
M19 AL.3 ON DELAY T.	Alarm-3 On delay time	0	9999	0	Sec.	52065
M20 AL.3 OFF DELAY T.	Alarm-3 Off delay time	0	9999	0	Sec.	52066
M21 AL.4 TYPE	Alarm-4 type <small>(HIGH,LOW,D.HIGH,D.LOW,D.BAND,D.RANG)</small>	HIGH	D.RANG	HIGH		52067
M22 AL.4 HYS	Alarm-4 Hysteresis	0	9999	0	°C	52068
M23 AL.4 ON DELAY T.	Alarm-4 On delay time	0	9999	0	Sec.	52069
M24 AL.4 OFF DELAY T.	Alarm-4 Off delay time	0	9999	0	Sec.	52070

5.2.13. RELAY OUTPUT 3 PAGE		Min	Max	Default	Unit	Mdb.Add.
N01 FUNCTION SELECT	Function Selection <small>(REVERS,DIRECT,LO.OUT)</small>	REVERS	LO.OUT	REVERS		52071
N02 CONTROL ALGORIT	Control Algorithm <small>(ONOFF,PID)</small>	ONOFF	PID	ONOFF		52072
N03 ON/OFF HYS.	ON/OFF Hysteresis	0	9999	0	°C	52073
N04 ON/OFF HYS FUNC.	ON/OFF Hysteresis Function	0	1	0		52074
N05 ON/OFF ON DLY TI	ON/OFF On delay time	0	9999	0	Sec.	52075
N06 LOG.OUT.OPER.	Logic Output Oper. <small>(EVENT,ALARM,MA.AUT) (SENBRK,OV.RNG,PROEND,GENERL)</small>	EVENT	PROEND	GENERL		52076
N07 REL. STEP EVENT	Related step event <small>(A,B,C,D)</small>	A	D	A		52077
N08 ALARM NUMBER	Alarm Number	1	4	1		52078
N09 AL.1 TYPE	Alarm-1 type <small>(HIGH,LOW,D.HIGH,D.LOW,D.BAND,D.RANG)</small>	HIGH	D.RANG	HIGH		52079
N10 AL.1 HYS	Alarm-1 Hysteresis	0	9999	0	°C	52080
N11 AL.1 ON DELAY T.	Alarm-1 On delay time	0	9999	0	Sec.	52081
N12 AL.1 OFF DELAY T.	Alarm-1 Off delay time	0	9999	0	Sec.	52082
N13 AL.2 TYPE	Alarm-2 type <small>(HIGH,LOW,D.HIGH,D.LOW,D.BAND,D.RANG)</small>	HIGH	D.RANG	HIGH		52083
N14 AL.2 HYS	Alarm-2 Hysteresis	0	9999	0	°C	52084
N15 AL.2 ON DELAY T.	Alarm-2 On delay time	0	9999	0	Sec.	52084
N16 AL.2 OFF DELAY T.	Alarm-2 Off delay time	0	9999	0	Sec.	52085
N17 AL.3 TYPE	Alarm-3 type	HIGH	D.RANG	HIGH		52086
N18 AL.3 HYS	Alarm-3 Hysteresis	0	9999	0	°C	52087
N19 AL.3 ON DELAY T.	Alarm-3 On delay time	0	9999	0	Sec.	52088
N20 AL.3 OFF DELAY T.	Alarm-3 Off delay time	0	9999	0	Sec.	52089
N21 AL.4 TYPE	Alarm-4 type <small>(HIGH,LOW,D.HIGH,D.LOW,D.BAND,D.RANG)</small>	HIGH	D.RANG	HIGH		52090
N22 AL.4 HYS	Alarm-4 Hysteresis	0	9999	0	°C	52091
N23 AL.4 ON DELAY T.	Alarm-4 On delay time	0	9999	0	Sec.	52092
N24 AL.4 OFF DELAY T.	Alarm-4 Off delay time	0	9999	0	Sec.	52093

5.2.14. RELAY OUTPUT 4 PAGE		Min	Max	Default	Unit	Mdb.Add.
O01 FUNCTION SELECT	Function Selection <small>(REVERS,DIRECT,LLO.OUT)</small>	REVERS	LO.OUT	REVERS		52095
O02 CONTROL ALGORIT	Control Algorithm <small>(ONOFF,PID)</small>	ONOFF	PID	ONOFF		52096
O03 ON/OFF HYS.	ON/OFF Hysteresis	0	9999	0	°C	52097
O04 ON/OFF HYS FUNC.	ON/OFF Hysteresis Function	0	1	0		52098
O05 ON/OFF ON DLY TI	ON/OFF On delay time	0	9999	0	Sec.	52099
O06 LOG.OUT.OPER.	Logic Output Oper. <small>(EVENT,ALARM,MA,AUT) (SENBK,OV.RNG,PROEND,GENEPL)</small>	EVENT	PROEND	ALARM		52100
O07 REL. STEP EVENT	Related step event	A	D	A		52101
O08 ALARM NUMBER	Alarm Number	1	4	1		52102
O09 AL.1 TYPE	Alarm-1 type <small>(HIGH,LOW,D.HIGH,D.LOW,D.BAND,D.RANG)</small>	HIGH	D.RANG	HIGH		52103
O10 AL.1 HYS	Alarm-1 Hysteresis	0	9999	0	°C	52104
O11 AL.1 ON DELAY T.	Alarm-1 On delay time	0	9999	0	Sec.	52105
O12 AL.1 OFF DELAY T.	Alarm-1 Off delay time	0	9999	0	Sec.	52106
O13 AL.2 TYPE	Alarm-2 type <small>(HIGH,LOW,D.HIGH,D.LOW,D.BAND,D.RANG)</small>	HIGH	D.RANG	HIGH		52107
O14 AL.2 HYS	Alarm-2 Hysteresis	0	9999	0	°C	52108
O15 AL.2 ON DELAY T.	Alarm-2 On delay time	0	9999	0	Sec.	52109
O16 AL.2 OFF DELAY T.	Alarm-2 Off delay time	0	9999	0	Sec.	52110
O17 AL.3 TYPE	Alarm-3 type <small>(HIGH,LOW,D.HIGH,D.LOW,D.BAND,D.RANG)</small>	HIGH	D.RANG	HIGH		52111
O18 AL.3 HYS	Alarm-3 Hysteresis	0	9999	0	°C	52112
O19 AL.3 ON DELAY T.	Alarm-3 On delay time	0	9999	0	Sec.	52113
O20 AL.3 OFF DELAY T.	Alarm-3 Off delay time	0	9999	0	Sec.	52114
O21 AL.4 TYPE	Alarm-4 type <small>(HIGH,LOW,D.HIGH,D.LOW,D.BAND,D.RANG)</small>	HIGH	D.RANG	HIGH		52115
O22 AL.4 HYS	Alarm-4 Hysteresis	0	9999	0	°C	52116
O23 AL.4 ON DELAY T.	Alarm-4 On delay time	0	9999	0	Sec.	52117
O24 AL.4 OFF DELAY T.	Alarm-4 Off delay time	0	9999	0	Sec.	52118

5.2.15. SERIAL COMM. PAGE		Min	Max	Default	Unit	Mdb.Add.
P01 COMM. ACC. ADDR.	Communication Access Address	1	247	1		52119
P02 COMM. BAUD RATE	Com. Baud Rate <small>(9600,1440,19200,38400)</small>	9600	38400	9600		52120
P03 PARITY SELECTION	Parity selection <small>(NONE,ODD,EVEN)</small>	NONE	EVEN	NONE		52121
P04 STOP BIT SELECT.	Stop Bit selection	0	1	0		52122
P05 MOD SELECT	Mode selection <small>(ASCII,RTU)</small>	ASCII	RTU	RTU		52123

5.2.16. DATE SETUP PAGE		Min	Max	Default	Unit	Mdb.Add.
Q01 DAY SETUP	Day Setup	1	31	1		52128
Q02 MONTH SETUP	Month Setup	1	12	1		52129
Q03 YEAR SETUP	Year Setup	0	99	10		52130
Q04 HOUR SETUP	Hour Setup	0	23	0		52131
Q05 MINUTE SETUP	Minute Setup	0	59	0		52132
Q06 SECOND SETUP	Second Setup	0	59	0		52133

5.2.17. PASSWORD PAGE		Min	Max	Default	Unit	Mdb.Add.
R01 OPERATOR PASSW.	Operator Password	0	9999	0		52135
R02 TECHNICIAN PASS.	Technician Password	0	9999	0		52136
R03 LOAD DEFAULTS	Load Default Parameters	0	1	0		52137

Note: To load default parameters, make R03 LOAD DEFAULTS 1 and restart the device.

6. How to Adjust Process Set Value

If the device is configured as Process Controller, process set value can be changed in three ways.

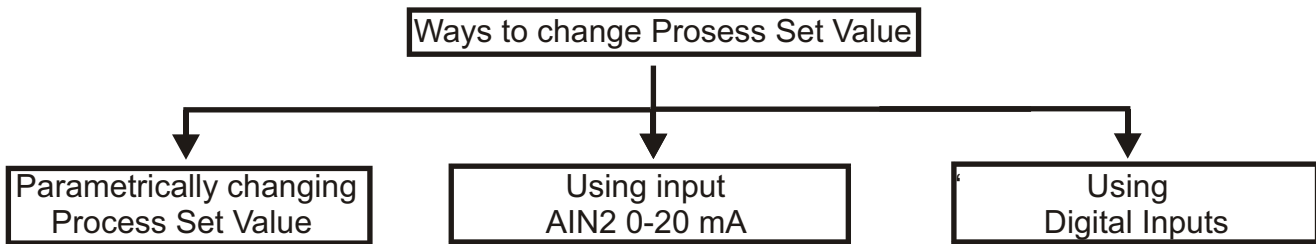

6.1. Parametrically Changing Process Set Value

By changing A02 Process Set Value parameter in the page OPERATOR PARAMETERS. (See Page 17/5.1)

6.2. Using Input AIN2 0-20 mA

When “D01 REMOTE SET SELCT” parameter is selected as **ON**, **AIN2 0/20 mA** input determines the Process Set Value.

For example, if it is desired Set Value is **0** for **0 mA** and **100** for **20 mA**, calibration type should be selected **DUALP** then **D04 DUAL PO. CAL MIN** parameter should be selected “**0**”, **D05 DUAL PO. CAL MAX** parameter should be selected “**100**”. So, for values of AIN2 input between 0 and 20 mA, Set Value changes linearly between 0 and 100.

(See Page 19/5.2.3)

6.3. Using Digital Inputs

If any of digital input function on **DIGITAL INPUT 1/2/3 PAGE** is selected as **SETSEL**, Set Value takes the value of a **SLCTABLE SET** defined on **OPERATORS PARAMETERS** page, according to status of digital inputs as explaining below.

DIGIN3	DIGIN2	DIGIN1	PROSES SET VALUE
PASSIVE	PASSIVE	PASSIVE	A12 SLCTABLE 1.SET
PASSIVE	PASSIVE	ACTIVE	A13 SLCTABLE 2.SET
PASSIVE	ACTIVE	PASSIVE	A14 SLCTABLE 3.SET
PASSIVE	ACTIVE	ACTIVE	A15 SLCTABLE 4.SET
ACTIVE	PASSIVE	PASSIVE	A12 SLCTABLE 5.SET
ACTIVE	PASSIVE	ACTIVE	A13 SLCTABLE 6.SET
ACTIVE	ACTIVE	PASSIVE	A14 SLCTABLE 7.SET
ACTIVE	ACTIVE	ACTIVE	A15 SLCTABLE 8.SET

7. PROFILE PROGRAM

7.1. Adjusting the Profile Program

Push the MENU button twice, to enter PROGRAM SETTINGS PAGE.

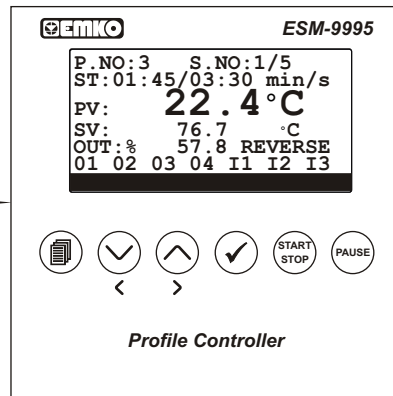

✓ To confirm and observe the settings, use OK button.

✓ To change values, use increment or Decrement buttons

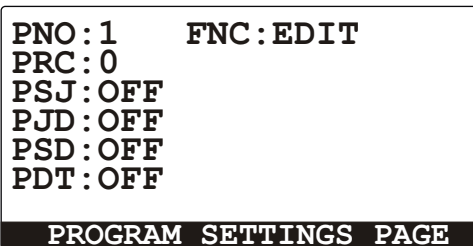

✓ If OK button is pressed, program setting page is entered and "FNC" tab becomes active.

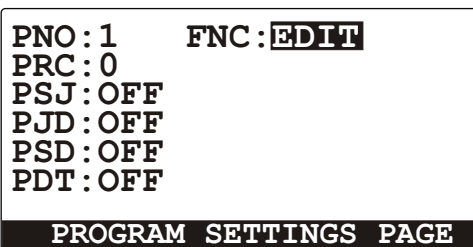

EDIT : To adjust and observe Program setting parameters or step parameters

COPY : To copy Programs or steps

DEL : To Delete Programs or steps

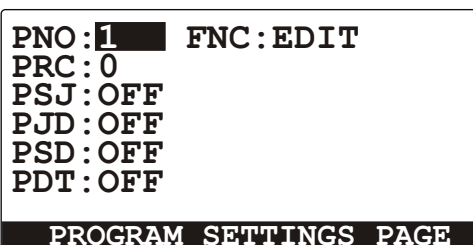

PNO:Program NO

It can be adjusted from 1 to **Max Program Number** (See the Page 18/5.2.1) parameter value.

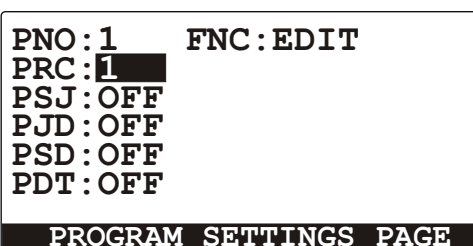

PRC:Program Repeat Cycle

It can be adjusted from INF to 99.

INF term means that, program repeats infinite.

Any of the Program and Step setting changing is accepted that, program is written.

If user wants to change any of the program or step setting with the EDIT function or choose COPY,DEL,INS function, device asks password for once, until user exit from program and step setting pages. It is optional that, password exits or not. It can be adjusted from technician parameters section.

```

PNO:1   FNC:EDIT
PRC:1
PSJ:OFF
PJD:OFF
PSD:OFF
PDT:OFF
PROGRAM SETTINGS PAGE

```

PSJ:Program Select Join

At the end of the Program, if this number exists, device joins this program number. It can be adjusted from OFF to 100.

```

PNO:1   FNC:EDIT
PRC:1
PSJ:OFF
PJD:OFF
PSD:OFF
PDT:OFF
PROGRAM SETTINGS PAGE

```

SJD:Start Program Join with Digital input
At the end of the Program, joining program starts with digital input signal.

```

PNO:1   FNC:EDIT
PRC:1
PSJ:OFF
PJD:OFF
PSD:OFF
PDT:OFF
PROGRAM SETTINGS PAGE

```

SDT:Program Start Date & Time
To start program on a certain month and hour and minute of a certain day.

```

PNO:1   FNC:EDIT
PRC:1
PSJ:OFF
PJD:OFF
PSD:OFF
PDT:OFF
PROGRAM SETTINGS PAGE

```

PDT:Program Delay Time
Delay time for start of the Program. Type is Hour/Minute.

After user confirm the last program parameter, step setting page is shown on the screen.

If **A24 PROFILE TYPE** parameter is selected as 0, Profil Program Setting Page is shown as bellow.

```

PNO:1   FNC:EDIT
SNO:1/50
SSV:0.0 °C
STG:00.00 min/s
SRP:0
STS:1
SEV:0/0/0/0/0/0
STEP SETTINGS PAGE

```

Edit function is using for observing and changing the step settings.

```

PNO:1   FNC:EDIT
SNO:1/50
SSV:0.0 °C
STG:00.00 min/s
SRP:0
STS:1
SEV:0/0/0/0/0/0
STEP SETTINGS PAGE

```

Program No
Program number is chosen.

 While user having operation on program or step setting page, if program button is pressed, then TAB is passive and pages can be change with increment or decrement buttons.

```
PNO:1   FNC:EDIT
SNO:1
SSV:0.0 °C
STG:00.00
SRP:0
STS:1
SEV:0/0/0/0/0/0
```

Step NO

Step number is chosen.

```
PNO:1   FNC:EDIT
SNO:1
SSV:0.0 °C
STG:00.00
SRP:0
STS:1
SEV:0/0/0/0/0/0
```

Step Set Value

Step Set Value is entering.

```
PNO:1   FNC:EDIT
SNO:1
SSV:23.8 °C
STG:00.00
SRP:0
STS:1
SEV:0/0/0/0/0/0
```

Step Time/Gradient

Step Time or Gradient is entering.

```
PNO:1   FNC:EDIT
SNO:1
SSV:23.8 °C
STG:11.45
SRP:0
STS:1
SEV:0/0/0/0/0/0
```

Step Repeat Cycle

Step Repeat Cycle is entering.

```
PNO:1   FNC:EDIT
SNO:1
SSV:23.8 °C
STG:11.45
SRP:1
STS:1
SEV:0/0/0/0/0/0
```

Step Target Step

Repeat action will be done from this step number.

```
PNO:1   FNC:EDIT
SNO:1
SSV:23.8 °C
STG:11.45
SRP:1
STS:1
SEV:1/0/0/0/0/0
```

Step Events

The Events that relates with the steps is chosen from this parameter.

A/B/C/D/E/F is chosen "0" means "OFF", "1" means "ON".

```
PNO:1   FNC:EDIT
SNO:2
SSV:45.7 °C
STG:20.30
SRP:0
STS:1
SEV:0/1/0/0/0/0
```

After last event situation is adjusted, cursor return to "SNO:". If you want to exit this loop press program button.

If **A24 PROFILE TYPE** parameter is selected as 1, Profile Program Setting Page is shown as bellow.

```
PROG NO:1
STEP NO:1
STP SET: 0.0 °C
STP TIM: 0 min
STP ALR:0
STP EVN:0
```

PROG NO parameter is used to select program number that will be changed.

```
PROG NO:1
STEP NO:1
STP SET: 0.0 °C
STP TIM: 0 min
STP ALR:0
STP EVN:0
```

STEP NO parameter is used to select step number that will be changed.

```
PROG NO:1
STEP NO:1
STP SET: 0 °C
STP TIM: 0 min
STP ALR:0
STP EVN:0
```

STP SET parameter is used to enter step set value.

```
PROG NO:1
STEP NO:1
STP SET: 0 °C
STP TIM: 0 min
STP ALR:0
STP EVN:0
```

STP SET parameter is used to enter step time.

```
PROG NO:1
STEP NO:1
STP SET: 0 °C
STP TIM: 0 min
STP ALR:0
STP EVN:0
```

STP ALR parameter is used to select "step end alarm". If it's 0 "step end alarm" doesn't occur.

Else, "step end alarm" appears at end of the step and program waits at there until passing next step by pressing INCREMENT BUT.

```
PROG NO:1
STEP NO:1
STP SET: 0 °C
STP TIM: 0 min
STP ALR:0
STP EVN:0
```

STP EVN parameter is used To select if A event is active while the step runs.

7.2. Copy Profile Program

```
PNO: 1   FNC: EDIT
PRC: 0
PSJ: OFF
SJD: OFF
SDT: OFF
PDT: OFF
```

COPY : To Copy Program to another program area.

```
PNO: 1   FNC: COPY
PRC: 0
PSJ: OFF
SJD: OFF
SDT: OFF
PDT: OFF
```

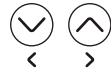

Change Function using increment and decrement button. Select "COPY".

```
PNO: 1 FNC: COPY
PRC: 0
PSJ: OFF
SJD: OFF
SDT: OFF
PDT: OFF
```



Press OK button and cursor position becomes "PNO:" to select source program no.

```
PNO: 4 FNC: COPY
PRC: 0
PSJ: OFF
SJD: OFF
SDT: OFF
PDT: OFF
```

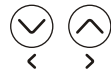

Change source program no using increment and decrement buttons.

```
PNO: 4   FNC: COPY 1
PRC: 0
PSJ: OFF
SJD: OFF
SDT: OFF
PDT: OFF
```



Press OK button and cursor position becomes "COPY" to select target program no.

```
PNO: 4   FNC: COPY 12
PRC: 0
PSJ: OFF
SJD: OFF
SDT: OFF
PDT: OFF
```

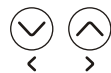

Change target program no using increment and decrement buttons.



Press OK button to copy program, that is near the PNO tab to another program, that is near the COPY tab. After copy operation, the message will appear bottom of the screen.

If target program is full, then "FIRSTLY DELETE TARGET" message is shown.

```
PNO:12  FNC: COPY  
PRC:0  
PSJ:OFF  
SJD:OFF  
SDT:OFF  
PDT:OFF  
PROG. COPY SUCCEFUL
```

```
PNO:4  FNC: COPY  
PRC:0  
PSJ:OFF  
SJD:OFF  
SDT:OFF  
PDT:OFF  
FIRSTLY DELETE TARGET
```

7.3. Delete Profile Program

```
PNO:1    FNC:EDIT
PRC:0
PSJ:OFF
PJD:OFF
PSD:OFF
PDT:OFF
PROGRAM SETTINGS PAGE
```

```
PNO:1    FNC:DEL
PRC:0
PSJ:OFF
PJD:OFF
PSD:OFF
PDT:OFF
PROGRAM SETTINGS PAGE
```



Change Function using increment and decrement button. Select "DEL".

```
PNO: 1 FNC:DEL
PRC:0
PSJ:OFF
PJD:OFF
PSD:OFF
PDT:OFF
PROGRAM SETTINGS PAGE
```



Press OK button and cursor position becomes "PNO:" tab. Select program number, that you want to delete.

```
PNO: 4 FNC:DEL
PRC:0
PSJ:OFF
PJD:OFF
PSD:OFF
PDT:OFF
PROGRAM SETTINGS PAGE
```

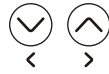

Change program no, that you want to delete, using increment and decrement buttons.

```
PNO:5    FNC:DEL
PRC:0
PSJ:OFF
PJD:OFF
PSD:OFF
PDT:OFF
PROG. DELETED
```



After OK button is pressed, the deleting program number is confirmed and cursor goes to "FNC" tab.



Press OK button again to delete the chosen program and next program will appear on the screen.

```
PNO:5    FNC:EDIT
PRC:0
PSJ:OFF
PJD:OFF
PSD:OFF
PDT:OFF
PROGRAM SETTINGS PAGE
```



After message is observed, press OK button to confirm. Cursor position becomes function select parameter and EDIT is shown.

7.4. Delete Step

```
PNO:1    FNC:EDIT
SNO:1
SSV:23.8 °C
STG:11.45
SRP:1
STS:1
SEV:1/0/0/0/0/0
STEP SETTINGS PAGE
```

```
PNO:1    FNC:DEL
SNO:1
SSV:23.8 °C
STG:11.45
SRP:1
STS:1
SEV:1/0/0/0/0/0
STEP SETTINGS PAGE
```

⏴ ⏵ Choose “DEL” function using increment and decrement buttons.

```
PNO:1    FNC:DEL
SNO:1
SSV:23.8 °C
STG:11.45
SRP:1
STS:1
SEV:1/0/0/0/0/0
STEP SETTINGS PAGE
```

✓ If OK button is pressed, cursor position becomes “PNO:” tab to select which program’s step will be deleted. Choose program no. using increment and decrement buttons and press OK button.

```
PNO:1    FNC:DEL
SNO:1
SSV:23.8 °C
STG:11.45
SRP:1
STS:1
SEV:1/0/0/0/0/0
STEP SETTINGS PAGE
```

⏴ ⏵ Press increment and decrement buttons to select step number.

```
PNO:1    FNC:DEL
SNO:1
SSV:23.8 °C
STG:11.45
SRP:1
STS:1
SEV:1/0/0/0/0/0
STEP SETTINGS PAGE
```

✓ If OK button is pressed, cursor position becomes function select tab again. If OK button is pressed on “DEL” tab, step is deleted.

```
PNO:1    FNC:DEL
SNO:1
SSV:42.9 °C
STG:10.30
SRP:0
STS:1
SEV:0/0/1/0/0/0
STEP DELETED
```

✓ After this step is deleted, next step settings is moved to deleted step. So following steps are moved previous steps one by one.

✓ After message is observed, press OK button to confirm. The cursor position becomes function select parameter and “EDIT” is shown.

7.5. Copy Step

```
PNO:1   FNC:EDIT
SNO:1
SSV:23.8 °C
STG:11.45
SRP:1
STS:1
SEV:1/0/0/0/0/0
STEP SETTINGS PAGE
```

```
PNO:1   FNC:COPY
SNO:1
SSV:23.8 °C
STG:11.45
SRP:1
STS:1
SEV:1/0/0/0/0/0
STEP SETTINGS PAGE
```

```
PNO:1   FNC:COPY
SNO:1
SSV:23.8 °C
STG:11.45
SRP:1
STS:1
SEV:1/0/0/0/0/0
STEP SETTINGS PAGE
```

```
PNO:1   FNC:COPY
SNO:1
SSV:23.8 °C
STG:11.45
SRP:1
STS:1
SEV:1/0/0/0/0/0
STEP SETTINGS PAGE
```

```
PNO:1   FNC:COPY 12
SNO:1
SSV:23.8 °C
STG:11.45
SRP:1
STS:1
SEV:1/0/0/0/0/0
STEP SETTINGS PAGE
```

```
PNO:1   FNC:COPY
SNO:1
SSV:23.8 °C
STG:11.45
SRP:1
STS:1
SEV:1/0/0/0/0/0
STEP COPIED
```

⏪ ⏩ Choose "COPY" function using increment and decrement buttons.

✓ If OK button is pressed, cursor position becomes "PNO:" tab to select source program number.

⏪ ⏩ Change source program no using increment and decrement buttons.

✓ If OK button is pressed, cursor position becomes "SNO:" tab to select source step number.

⏪ ⏩ Change source step no using increment and decrement buttons.

✓ If OK button is pressed, cursor position becomes near "COPY" tab to select target step number.

⏪ ⏩ Change target step no using increment and decrement buttons.

✓ If OK button is pressed, copy operation come true and related message is shown on the screen.

✓ Press OK button again and message will disappear and tab return to EDIT.

7.6. Insert Step

```
PNO:1    FNC:EDIT
SNO:1
SSV:23.8 °C
STG:11.45
SRP:1
STS:1
SEV:1/0/0/0/0/0
STEP SETTINGS PAGE
```

```
PNO:1    FNC:INS
SNO:1
SSV:23.8 °C
STG:11.45
SRP:1
STS:1
SEV:1/0/0/0/0/0
STEP SETTINGS PAGE
```

```
PNO:1    FNC:INS
SNO:1
SSV:23.8 °C
STG:11.45
SRP:1
STS:1
SEV:1/0/0/0/0/0
STEP SETTINGS PAGE
```

```
PNO:1    FNC:INS
SNO:1
SSV:23.8 °C
STG:11.45
SRP:1
STS:1
SEV:1/0/0/0/0/0
STEP SETTINGS PAGE
```

```
PNO:1    FNC:INS
SNO:1
SSV:23.8 °C
STG:11.45
SRP:1
STS:1
SEV:1/0/0/0/0/0
STEP SETTINGS PAGE
```

```
PNO:1    FNC:INS
SNO:2
SSV:23.8 °C
STG:11.45
SRP:1
STS:1
SEV:1/0/0/0/0/0
STEP INSERTED
```

⏪ ⏩ Choose "INS" function using increment and decrement buttons.

✓ If OK button is pressed, cursor position becomes "PNO:" tab to select source program number.

⏪ ⏩ Change source program no using increment and decrement buttons.

✓ If OK button is pressed, cursor position becomes "SNO:" tab to select source step number.

⏪ ⏩ Change source step no using increment and decrement buttons.



✓ If OK button is pressed, cursor position becomes "INS" tab.



✓ If OK button is pressed again, following steps after the SNO number is shifted the next steps. The source step settings is copied to opened area and related message is shown.



✓ Press OK button again and message will disappear and tab return to EDIT.

4.11. Running of Profile Program

While profile program isn't running, the message "**PROGRAM STOPPED**" appears on the screen. To start to run the program, you should press the button . After selecting the number of program that is desired to run, you should press START/STOP button again to start the program, .

To pause the running program,  button must be pressed. When program is paused, the message "**PROGRAM HOLDING**" appears on the screen.  Button must be pressed to run the program again.

When program is running or holding, you should press  or  buttons to decrease or increase the step number.

While program is running, by pressing  button, program pauses and "confirmation to stop" page appears. By pressing  button, it is confirmed to stop program or by pressing  button it is canceled to stop program and program returns to run.

8. Modbus Addresses

8.1 Read Input Registers Modbus Addresses

PARAMATER	MODBUS ADDRESS
PROCESS VALUE	30001
PID OUTPUT VALUE	30002
SET VALUE	30003
ANALOG OUTPUT - 1 VALUE	30004
ANALOG OUTPUT - 2 VALUE	30005
MOTORIZED VALVE FEEDBACK VALUE	30006
STEP REPEAT CYCLE	30007
RUNNING STEP TIME SET	30008
RUNNING STEP PASSED TIME	30009
RUNNING PROGRAM PASSED TIME (HOUR)	30010
RUNNING PROGRAM PASSED TIME (MIN. & SEC.)	30011
RUNNING STEP NUMBER	30012
RUNNING PROGRAM NUMPER	30013
RUNNING PROGRAM STATE (4:RUN 2:HOLD 1:STOP)	30014
INSTRUMENT TYPE & REVISION NUMBER	30015
RELAY - 1 FUNCTION SELECT (0:Direct 1:Inverse)	30016
RELAY - 1 CONTROL ALGORİTHM SELECT (2:LOGITOUT 3:ONOFF 4:PID)	30017
RELAY - 2 FUNCTION SELECT (0:Direct 1:Inverse)	30018
RELAY - 2 CONTROL ALGORİTHM SELECT (2:LOGITOUT 3:ONOFF 4:PID)	30019
RELAY - 3 FUNCTION SELECT (0:Direct 1:Inverse)	30020
RELAY - 3 CONTROL ALGORİTHM SELECT (2:LOGITOUT 3:ONOFF 4:PID)	30021
RELAY - 4 FUNCTION SELECT (0:Direct 1:Inverse)	30022
RELAY - 4 CONTROL ALGORİTHM SELECT (2:LOGITOUT 3:ONOFF 4:PID)	30023
ANALOG OUTPUT 1 FUNCTION SELECT (4:OFF 5:INV 6:DIR 7:RET)	30024
ANALOG OUTPUT 2 FUNCTION SELECT (4:OFF 5:INV 6:DIR 7:RET)	30025

8.2. Profile Programs Modbus Adresses

PROGRAM PARAMETERS	MODBUS ADDRESS
N. PROGRAM REPEAT CYCLE	$40028 + 8*(N-1)+0$
N. PROGRAM SELECT JOIN	$40028 + 8*(N-1)+1$
N. PROGRAM NEXT PROGRAM SELECT SEGMENT	$40028 + 8*(N-1)+2$
N. PROGRAM START TIME	$40028 + 8*(N-1)+3$
N. PROGRAM START DATE - 1	$40028 + 8*(N-1)+4$
N. PROGRAM START DATE - 2	$40028 + 8*(N-1)+5$
N. PROGRAM DELAY TIME	$40028 + 8*(N-1)+6$
N. PROGRAM WHETHER PROGRAM IS CREATED	$40028 + 8*(N-1)+7$

Example: How to calculate modbuss address of 12. Program's "Program Start Date-1" parameter:

N = 12:

Address = $40828 + 8*(12-1) + 4 = 40920$

8.3. Profile Steps Modbus Adresses

STEP PARAMETERS	MODBUSS ADDRESS
N. STEP SET VALUE	$40828 + 11*(N-1)+0$
N. STEP SET TIME	$40828 + 11*(N-1)+1$
N. STEP GRADIENT	$40828 + 11*(N-1)+2$
N. STEP CYCLE	$40828 + 11*(N-1)+3$
N. STEP TARGET SEGMENT	$40828 + 11*(N-1)+4$
N. STEP EVENT 1	$40828 + 11*(N-1)+5$
N. STEP EVENT 2	$40828 + 11*(N-1)+6$
N. STEP EVENT 3	$40828 + 11*(N-1)+7$
N. STEP EVENT 4	$40828 + 11*(N-1)+8$
N. STEP EVENT 5	$40828 + 11*(N-1)+9$
N. STEP EVENT 6	$40828 + 11*(N-1)+10$

Example: How to calculate modbuss address of 7. Step's Step Cycle parameters:

N = 7:

Address = $40828 + 11*(7-1) + 3 = 40897$

To calculate modbus address of any of Nth step's parameter of Mth program, you may use the following equations.

PROFILE STEPS PARAMETERS	MODBUS ADDRESS
Nth STEP of Mth PROGRAM SET VALUE	$40828 + 11*((M-1)*MSN + N-1)+0$
Nth STEP of Mth PROGRAM SET TIME	$40828 + 11*((M-1)*MSN + N-1)+1$
Nth STEP of Mth PROGRAM GRADIENT	$40828 + 11*((M-1)*MSN + N-1)+2$
Nth STEP of Mth PROGRAM CYCLE	$40828 + 11*((M-1)*MSN + N-1)+3$
Nth STEP of Mth PROGRAM TARGET SEGMENT	$40828 + 11*((M-1)*MSN + N-1)+4$
Nth STEP of Mth PROGRAM EVENT 1	$40828 + 11*((M-1)*MSN + N-1)+5$
Nth STEP of Mth PROGRAM EVENT 2	$40828 + 11*((M-1)*MSN + N-1)+6$
Nth STEP of Mth PROGRAM EVENT 3	$40828 + 11*((M-1)*MSN + N-1)+7$
Nth STEP of Mth PROGRAM EVENT 4	$40828 + 11*((M-1)*MSN + N-1)+8$
Nth STEP of Mth PROGRAM EVENT 5	$40828 + 11*((M-1)*MSN + N-1)+9$
Nth STEP of Mth PROGRAM EVENT 6	$40828 + 11*((M-1)*MSN + N-1)+10$

MSN: Maximum Step Number in a program.

Example for calculation of modbuss address of 5th Step's Cycle parameters of 3th program (Maximum step number in a program has been given as 16)

N = 5,

M = 3:

Address = $40828 + 11*((3-1)*16+5-1)+3 = 41227$

9. Motorized Valve Control

To be able to control motorized valve, **A20 MOTORIZD CONTROL** (See the Page 17/5.1) parameter should be selected **DIRECT** or **REVERS**.

When A20 parameter is selected **DIRECT** or **REVERS**, **RELAY 1** and **RELAY 2** are reserved for motorized valve control. **RELAY 1** works in the direction to open the valve and **RELAY 2** works in the direction to close valve.

If **E01 FEEDBACK CONTROL** parameter is selected **FBACK**, the position information of motorized valve is read by 1-10 k potentiometer. If **E01** parameter is selected **FLOAT**, the device calculates the position of the valve.

E02 BOUNDL.MOV.TIME is the time to reach the valve from fully closed position to fully open position. For the proper valve control, this parameter should be entered properly. To determine this parameter, when valve is fully closed, manually open the valve continuously. Adjust this parameter as more than %5 value of the time that you measured.

E03 VALVE DEAD BAND parameter is the band of minimum moving time of the valve. This parameter is % of E02 parameter. If the valve oscillates, this parameter's value should be increased.

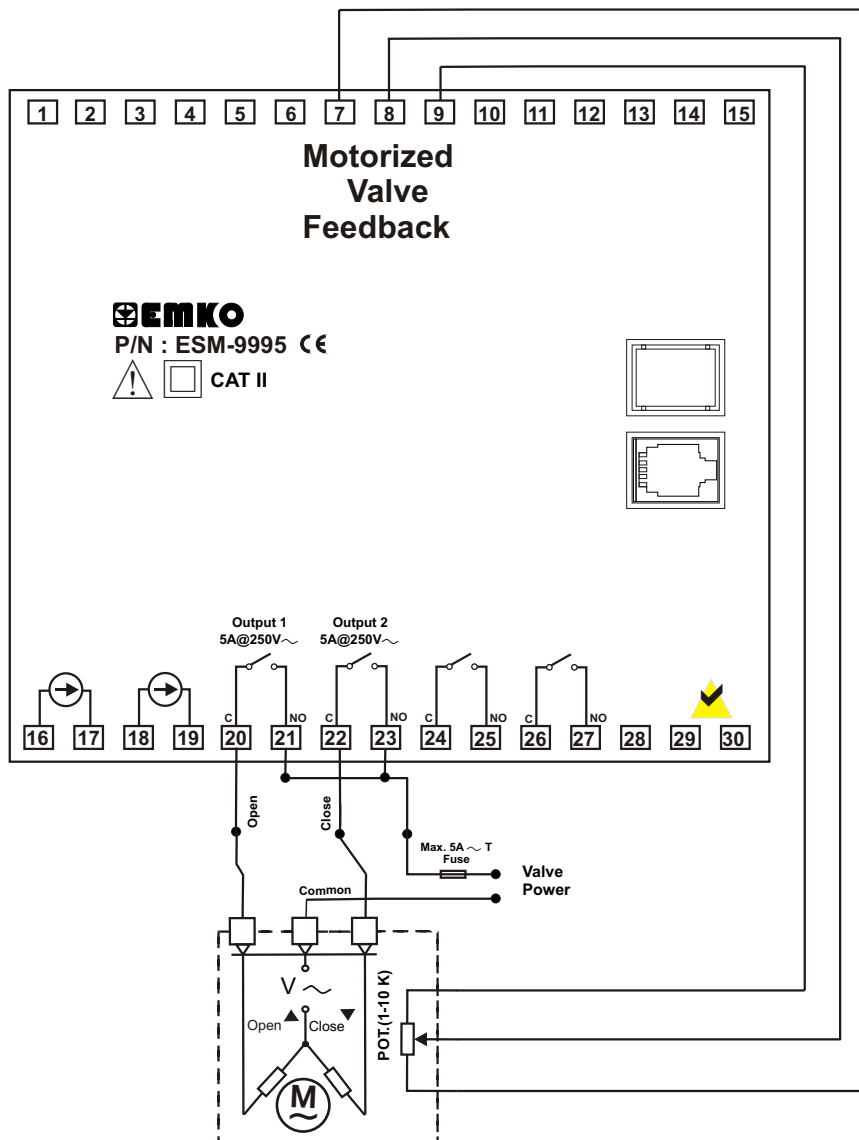

10. Example of Profile Program

A Program Example with 5 Steps.

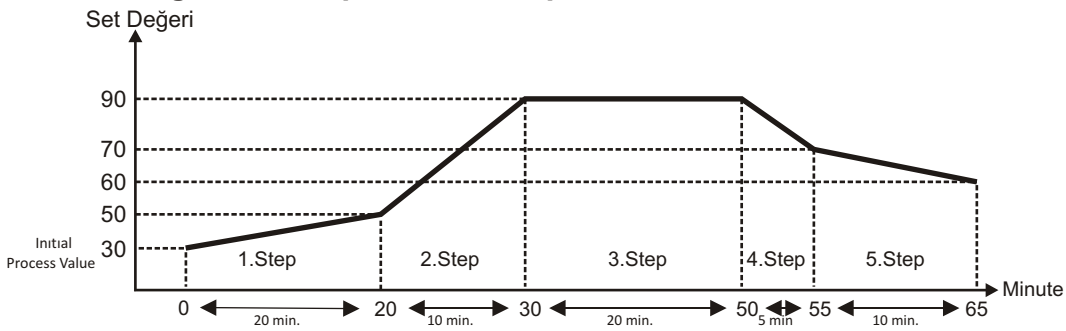

A profile program can be create in two ways.

1- By entering set value that is reached at the end of step and step time.
 (If **B05 PR. STEP RAMP TYP** parameter is selected as **TIME**)

PNO: 1	PNO: 1	PNO: 1	PNO: 1	PNO: 1	PNO: 1
SNO: 1	SNO: 2	SNO: 3	SNO: 4	SNO: 5	SNO: 6
SSV: 50	SSV: 90	SSV: 90	SSV: 70	SSV: 60	SSV: 60
STG: 20	STG: 10	STG: 20	STG: 5	STG: 15	STG: END

1- By entering set value that is reached at the end of step and increment of set value in the unit time.

(If **B05 PR. STEP RAMP TYP** parameter is selected as **GRADI.**)

- 1.Step: Set Value has reached from 30 to 50 in 20 minutes. Increment per minute is 1
- 2.Step: Set Value has reached from 50 to 90 in 10 minutes. Increment per minute is 4
- 3.Step: Set Value is constant. Waiting time is 20 minutes.
- 4.Step: Set Value has reached from 90 to 70 in 5 minutes. Increment per minute is -4
- 5.Step: Set Value has reached from 70 to 60 in 10 minutes. Increment per minute is -1

PNO: 1	PNO: 1	PNO: 1	PNO: 1	PNO: 1	PNO: 1
SNO: 1	SNO: 2	SNO: 3	SNO: 4	SNO: 5	SNO: 6
SSV: 50	SSV: 90	SSV: 90	SSV: 70	SSV: 60	SSV: 60
STG: 1	STG: 4	STG: 0 SGS: 20	STG: -4	STG: -1	STG: END

11. Specifications

Device Type	: Profile Controller unit
Housing & Mounting	: 96mm x 96mm x 87.5mm 1/4 DIN 43700 plastic housing for
Panel mounting.	Panel cut-out is 92x92mm.
Protection Class	: NEMA 4X (IP65 at front, IP20 at rear).
Weight	: Approximately 0.34 Kg.
Environmental Ratings	: Standard, indoor at an altitude of less than 2000 meters with none condensing humidity.
o o o o Storage/Operating Temperature:	-40 C to +85 C / 0 C to +50 C
Storage/Operating Humidity	: 90 % max. (None condensing)
Installation	: Fixed installation
Overvoltage Category	: II
Pollution Degree	: II, office or workplace, none conductive pollution
Operating Conditions	: Continuous
Supply Voltage and Power	: 100 - 240 V V (-%15 / +%10) 50/60 Hz. 6VA
24 V V (-%15 / +%10) 50/60 Hz. 6VA	
24 V Z (-%15 / +%10) 6W	
Analogue input 1	: Universal input (TC, RTD, ZVoltage/Current)
Termocouple input types	: Selectable by parameters
L (DIN43710) ,	
J ,K ,R ,S ,T ,B ,E ,N (IEC584.1)(ITS90) , C (ITS90)	
Thermoresistance Input Types	: PT 100 (IEC751) (ITS90)
ZVoltage Input Types	: Selectable by parameters 0...50mVZ, 0...5VZ, 0...10VZ
ZCurrent Input Types	: Selectable by parameters 0...20mAZ, 4...20mAZ
Analogue input 2	: Remote Set input (0...20mAZ, 4...20mAZ)
Analogue input 3	: Motorized Valve Feedback Potantiometer input.(1K-10K)
Accuracy	: $\pm 0,25\%$ of full scale for thermocouple, thermoresistance and voltage, $\pm 0,70\%$ of full scale for current.
Cold Junction Compensation:	Automatically $\pm 0.1^{\circ}\text{C}/1^{\circ}\text{C}$.
Line Compensation	: Maximum 10 .
Sensor Break Protection	: Upscale
Sampling Cycle	: 100 millisecond.
Input Filter	: 0.0 to 900.0 seconds
Giriş Resistance	: TC and RTD inputs > 10MW
Current input	: 100W, 0...50mV > 10MW, 0...10V > 43KW
Digital inputs	: 3 input with isolation
Transmitter Supply output	: 24V Z $\pm 10\%$ max. 50mA
Standard Relay Outputs	: 5A@250V (Programmable control or alarm output)
(Electrical Life	: 100.000 Operation (Full Load))
Analogue Outputs	: 2 output. Selectable 0-4...20mA Z and/or 0-2...10V Z
Must be determined in order.	
Profile Programs and Steps	: 100 Program to 1000 Step
Control Forms	: Programmable ON / OFF, P, PI, PD or PID.
Standard Communication	: RS-232 Communication
Communication Protocol	: MODBUS-RTU,ASCII
Display Type	: 128x64 graphic LCD with backlight

12. Other Informations

Manufacturer Information:

Emko Elektronik Sanayi ve Ticaret A.Ş.
Demirtaş Organize Sanayi Bölgesi Karanfil Sk. No:6 16369
BURSA/TURKEY
Phone : +90 224 261 1900
Fax : +90 224 261 1912

Repair and Maintenance Service Information:

Emko Elektronik Sanayi ve Ticaret A.Ş.
Demirtaş Organize Sanayi Bölgesi Karanfil Sk. No:6 16369
BURSA/TURKEY
Phone : +90 224 261 1900
Fax : +90 224 261 1912



Thank you very much for your preference to use Emko Elektronik Products.

www.emkoelektronik.com.tr